

SSI 200-2500

Stainless Steel Indirect Cylinders for DHW Applications

The Adveco range of stainless steel domestic hot water tanks includes models suitable for use as hot water buffers, single coil, or dual coil calorifiers as required for the job.

The SSI range is supplied with a single internal stainless steel heat exchange coil at low level to serve as indirect calorifiers. The high capacity coil is removable to allow for tank and heat exchanger cleaning. Each tank has an option for a large or small coil depending on the building's DHW requirements and available boiler power. The SSI range has a flanged port for an electric immersion heating element from 3 kW to 36 kW to provide a level of redundancy to a domestic hot water installation.

The complete range of tanks are WRAS certified, and are designed and manufactured to the requirements of the Pressure Equipment Directive (97/23/EC) and are tested to the procedure defined in BS EN 12897:2006.

FEATURES

- Available with 200 - 2500 litre capacities
- Produced from high quality stainless steel
- Single internal heat exchange coil
- 100-130 mm removable insulation for improved energy efficiency
- Suitable for vented or unvented installation
- Immersion heaters available from 3 - 36 kW
- 6 bar / 85°C max. working pressure/temp (tank)
- 12 bar / 110°C max. working pressure/temp (coil)

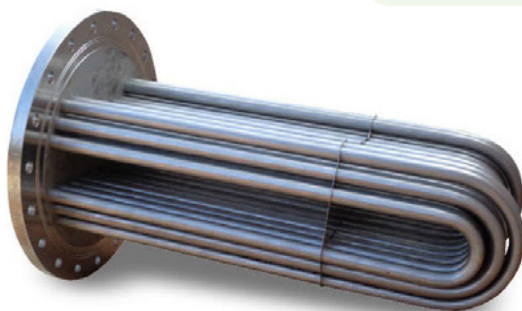

CERTIFICATION MARK

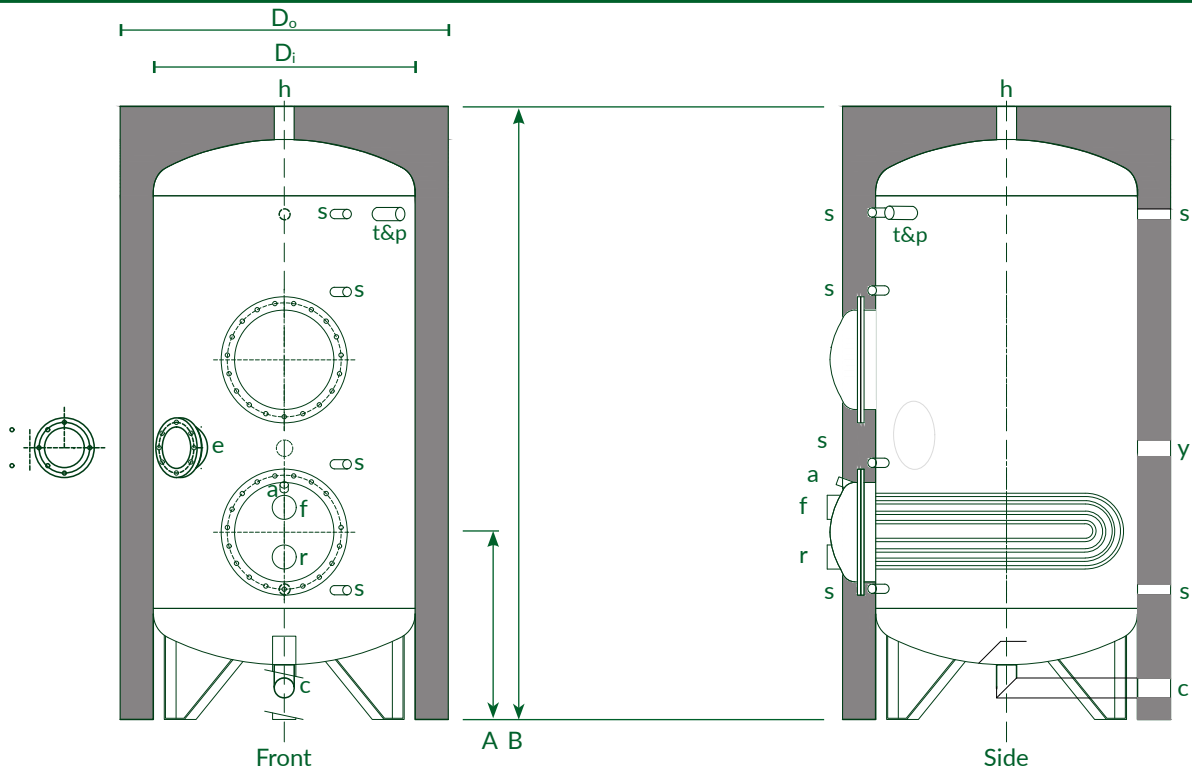

Model	units	SSI 200/1.0	SSI 300/1.0	SSI 500/1.5	SSI 800/1.5	SSI 800/3.0	SSI 1000/5.0	SSI 1500/4.0	SSI 1500/6.0	SSI 2000/4.0	SSI 2000/6.0	SSI 2500/4.0	SSI 2500/6.0	
Volume	L	188	283	476	758	753	935	1413	1407	1989	1983	2522	2516	
D _o	mm	650	700	850	1050	1050	1050	1260	1260	1510	1510	1660	1660	
D _i	mm	450	500	650	790	790	790	1000	1000	1250	1250	1400	1400	
A	mm	445	465	485	595	595	545	620	620	690	690	730	730	
B	mm	1445	1735	1785	1865	1865	2195	2250	2250	2090	2090	2180	2180	
c Cold Inlet	inch	1.25	1.50	1.50	2.00	2.00	2.00	2.00	2.00	2.00	2.00	2.50	2.50	
h Hot Outlet	inch	1.25	1.50	1.50	2.00	2.00	2.00	2.00	2.00	2.00	2.00	2.50	2.50	
y Secondary	inch	1.50	1.50	1.50	1.50	1.50	1.50	1.50	1.50	1.50	1.50	1.50	1.50	
s Sensor	inch	0.75	0.75	0.75	0.75	0.75	0.75	0.75	0.75	0.75	0.75	0.75	0.75	
t&p Temperature & Pressure Relief	inch	1.00	1.00	1.00	1.00	1.00	1.50	1.50	1.50	1.50	1.50	1.50	1.50	
e Immersion Port	inch, mm	2.25"	2.25"	180	180	180	180	180	180	180	180	180	180	
a Air Relief (Coil)	inch	%	%	%	%	%	%	%	%	%	%	%	%	
f/r Primary Flow/Return	inch	1.00	1.00	2.00	2.00	2.00	2.00	2.00	2.00	2.00	2.00	2.00	2.00	
Standing losses	W kWh/24h	75 1.8	96 2.3	100 2.4	120 2.9	120 2.9	143 3.4	158 3.8	158 3.8	190 4.5	190 4.5	208 4.9	208 4.9	
Energy efficiency class		C	C	C	C	C	C	C	C	C	C	C	C	
Empty mass	kg	126	150	199	244	255	335	379	394	449	464	502	517	
Coil Data (80/60°C)	Surface Area	m ²	1.0	1.0	1.5	1.5	3.0	5.0	4.0	6.0	4.0	6.0	4.0	6.0
	Volume	L	3.5	3.5	5.5	5.5	10.0	16.7	13.5	20	13.5	20	13.5	20
	Maximum Pressure	bar	12	12	12	12	12	12	12	12	12	12	12	12
	Nominal Capacity	kW	18	18	27	27	54	90	72	108	72	108	72	108
	Primary Flow Rate	L/s	0.25	0.25	0.38	0.38	0.75	1.25	1.00	1.50	1.00	1.50	1.00	1.50
	Pressure Drop	mbar	3	3	5	5	8	19	10	25	10	25	10	25
	DHW Recovery	L/h	309	309	463	463	927	1544	1236	1853	1236	1853	1236	1853
	DHW Peak ½hr Flow	L	279	355	574	799	989	1392	1645	1898	2106	2359	2532	2785
DHW Peak 1hr Flow	L	436	512	808	1034	1458	2174	2271	2836	2732	3297	3158	3724	
DHW Peak 2hr Flow	L	742	818	1269	1494	2378	3708	3498	4678	3959	5139	4386	5565	

Ancillaries: All models

Control Thermostat: E0008/0-95C	Overheat Thermostat: E0011
Thermostat Pocket: E0009.2 (2x included with vessel)	Destratification Pump Kit: MB0001
Unvented Kits: Contact Advenco for details	Electric Immersion Heaters: Contact Advenco for details

Advenco Ltd. Unit 7&8 Armstrong Mall, Southwood Business Park, Farnborough, Hampshire GU14 0NR
Company Reg : 09493966 T : 01252 551 540 E : enquiries@advenco.co I : www.advenco.co

The WRAS Approved Product Certification Mark is registered property of Water Regulations Advisory Scheme Limited (WRAS Ltd.)