

TOTEM

Cogeneration (CHP) Range

A+++



Highest total efficiency
with modulating output
and lowest NO_x
emissions available



PRACTICAL, EFFICIENT & SUSTAINABLE
BUILDING SERVICES SOLUTIONS

Totem Product Range

MODEL		T10	T20	T25	T50
OUTPUT air inlet @ 25°C and 101.3 kPa, natural gas (G20) @ 20 mbar					As 2× T25
MAX Output:					
Rated electrical power	kW	10	20	25	50
Power modulation range	kW	≥5	≥7.5	≥7.5	≥7.5
Seasonal space heating efficiency†	%	200	226	251	251
Electrical efficiency (net of machine consumption)*	% LHV (HHV)	29.6 (26.9)	31.2 (28.4)	32.5 (29.5)	32.5 (29.5)
Thermal output (35°C return temperature)*	kW	25.0	48.5	57.6	115.2
Thermal output (70°C return temperature)*	kW	21.6	41.9	50.2	100.4
Thermal efficiency (35°C return temperature)*	% LHV (HHV)	74.7 (67.7)	75.6 (68.7)	74.9 (68.1)	74.9 (68.1)
Thermal efficiency (70°C return temperature)*	% LHV (HHV)	64.0 (58.1)	65.3 (59.4)	65.3 (59.4)	65.3 (59.4)
Total efficiency (35°C return temperature)*	% LHV (HHV)	104.3 (94.7)	106.8 (97.1)	107.4 (97.6)	107.4 (97.6)
Total efficiency (70°C return temperature)*	% LHV (HHV)	93.6 (84.8)	96.5 (87.7)	97.8 (88.9)	97.8 (88.9)
Gas energy input*	kW LHV (HHV)	33.4 (37.0)	64.0 (70.9)	76.6 (84.9)	76.6 (84.9)
Natural gas (G20)*	Nm ³ /hr	3.29	6.27	7.56	15.12
Heat to power ratio**		2.50	2.42	2.30	2.30

LHV = Lower Heat Value (Net)

HHV = Higher Heat Value (Gross)

Total Efficiency vs. Electric Load

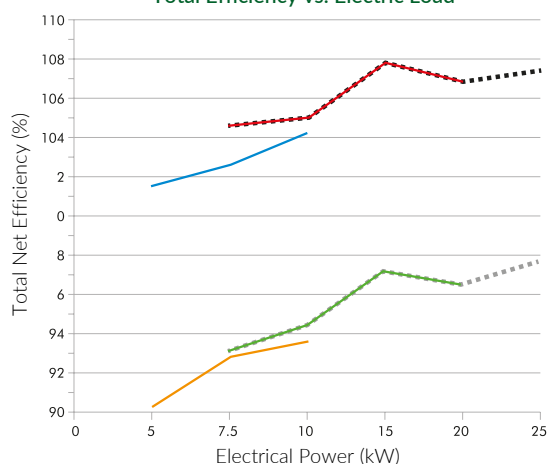

Electrical Efficiency vs. Electric Load

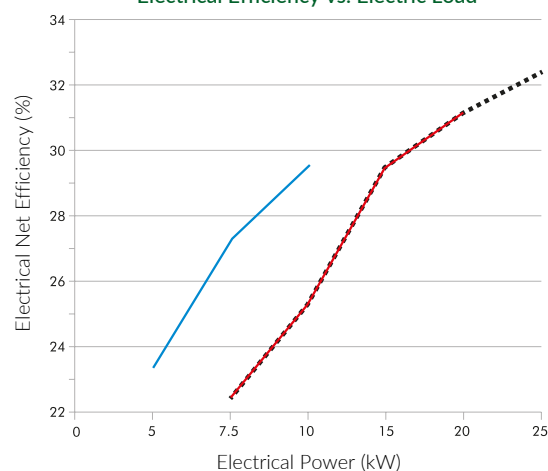

Thermal Power vs. Electric Load

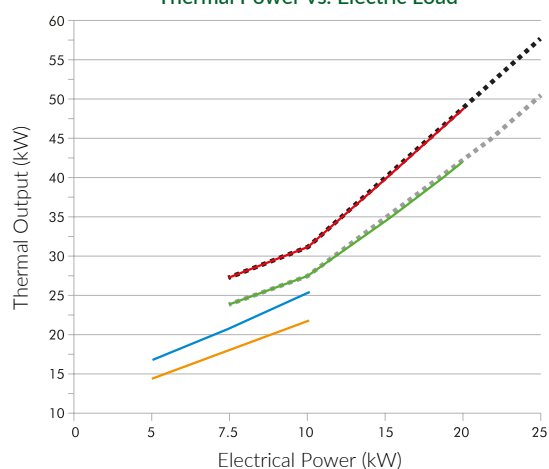

Input Power vs. Electric Load

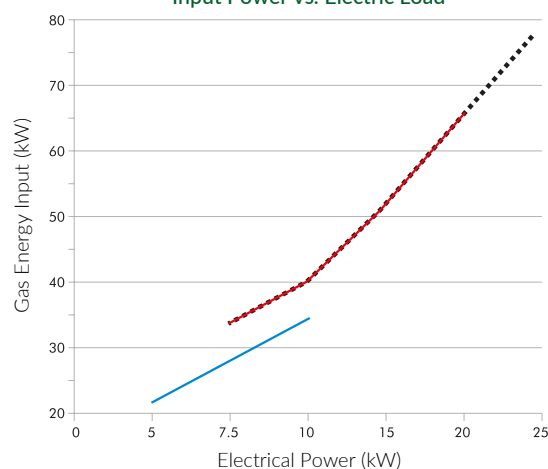

— TOTEM 10 @ 35°C — TOTEM 20 @ 35°C - - - TOTEM 25 @ 35°C
— TOTEM 10 @ 70°C — TOTEM 20 @ 70°C - - - TOTEM 25 @ 70°C

— TOTEM 10 @ 35-70°C — TOTEM 20 @ 35-70°C - - - TOTEM 25 @ 35-70°C

* Values from independent testing at Milan Technical University and verified by TÜV Rheinland. Unit certified by TÜV Rheinland.

** Heat to Power ratio must be input into SBEM calculations alongside Maximum Gross (HHV) Total Efficiency. For normally stated net efficiencies, divide by 1.1 to calculate gross efficiency.

† As defined by EU No. 811/2013, EN 50465/2015

MODEL		T10	T20	T25	T50
OUTPUT air inlet @ 25°C and 101.3 kPa, natural gas (G20) @ 20 mbar					As 2x T25
Modulating 40/50% Output:					
Rated Electrical Power	kW	5	10	10	10
Electrical efficiency (net of machine consumption)*	% LHV (HHV)	23.7 (21.4)	25.5 (23.0)	25.5 (23.0)	25.5 (23.0)
Thermal output (35°C return temperature) *	kW	16.4	30.9	30.9	30.9
Thermal output (70°C return temperature)*	kW	14.1	27.0	27.0	27.0
Thermal efficiency (35°C return temperature)*	% LHV (HHV)	77.9 (70.5)	79.4 (71.7)	79.4 (71.7)	79.4 (71.7)
Thermal efficiency (70°C return temperature)*	% LHV (HHV)	70.0 (60.5)	69.2 (62.5)	69.2 (62.5)	69.2 (62.5)
Total efficiency (35°C return temperature)*	% LHV (HHV)	101.5 (91.6)	105.0 (94.8)	105.0 (94.8)	105.0 (94.8)
Total efficiency (70°C return temperature)*	% LHV (HHV)	90.3 (81.5)	94.4 (85.2)	94.4 (85.2)	94.4 (85.2)

DIMENSIONS AND WEIGHTS

h x w x l (rigged up with panels - standard version without feet)	mm	1,280x795x1,924			1,280x2,390x1,924
Weight Full	kg	720	780	780	1560

HYDRAULIC CIRCUIT

Maximum inlet water temperature	°C	70			
Maximum outlet water temperature	°C	80			
Rated water flow	l/h	2,500	4,000	5,000	10,000
Maximum pressure drop through unit	kPa	60			
Maximum working pressure	bar	10			

ASYNCHRONOUS GENERATOR

Operation		In parallel with grid			
Three phase voltage/Frequency	V/Hz	400/50			
Engine starter		Starter motor			
Electrical generator connection		3 phase and neutral			

WORKING CONDITIONS

Max Ambient Conditions (temperature/relative humidity)	°C/RH	40/75%			
Acoustic impact Lp					
@ 1 m distance in open field	dB(A)	56.7	61.1	61.1	64.1
Exhaust emission					
NO _x Emissions @ 5% O ₂	mg/Nm ³	<10	<10	<10	<10
NO _x Emissions @ 0% O ₂	mg/kWh	<12	<12	<12	<12
CO Emissions @ 5% O ₂	mg/Nm ³	<10	<10	<10	<10
Max flue gas temperature (normal conditions)	°C	77			
Max flue gas temperature (fault condition)	°C	100			
Flue gas mass flow rate	kg/h	55	100	125	250
Condensate mass flow rate (35°C return temperature)*	kg/h	1.37	3.04	3.14	6.28
Max flue system pressure drop	Pa	500			
Max flue run (80mm PP flue) Total Equivalent Length*	m	32	23	23	23
Flue material specification		T120 and H1			
Asynchronous three-phase alternator					
Rated power*	kW	10.10	20.09	25.06	50.12
Frequency	Hz	50			
Rated voltage	V	400			
Poles		4	2	2	2
Insulation Class		F			
Efficiency Class		IE3			
Power Factor		0.962			

* Values from independent testing at Milan Technical University and verified by TÜV Rheinland. Unit certified by TÜV Rheinland.

** Heat to Power ratio must be input into SBEM calculations alongside Maximum Gross (HHV) Total Efficiency. For normally stated net efficiencies, divide by 1.1 to calculate gross efficiency.

† As defined by EU No. 811/2013, EN 50465/2015

Technical drawings

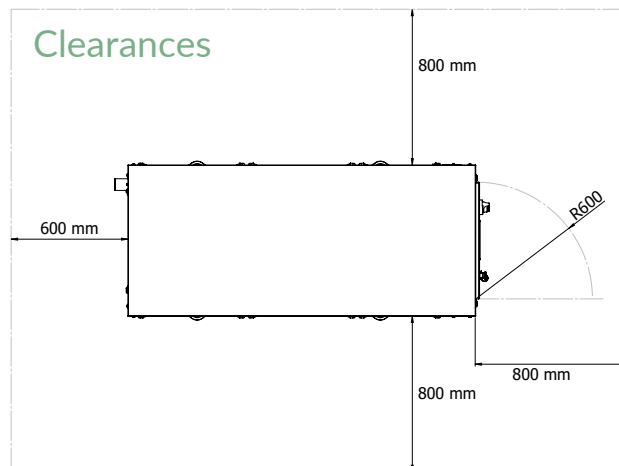
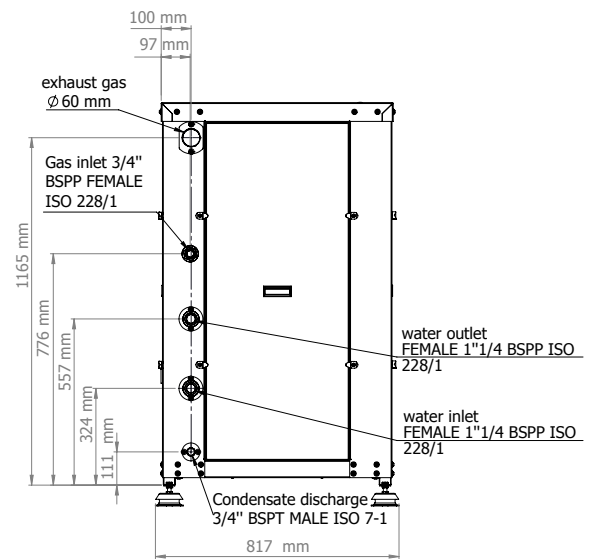
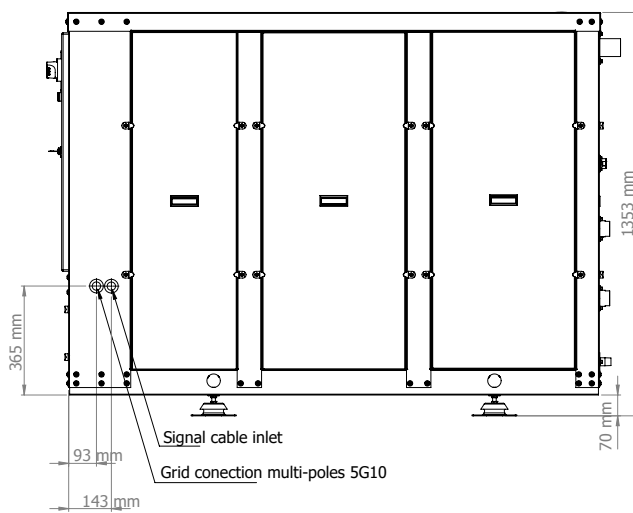
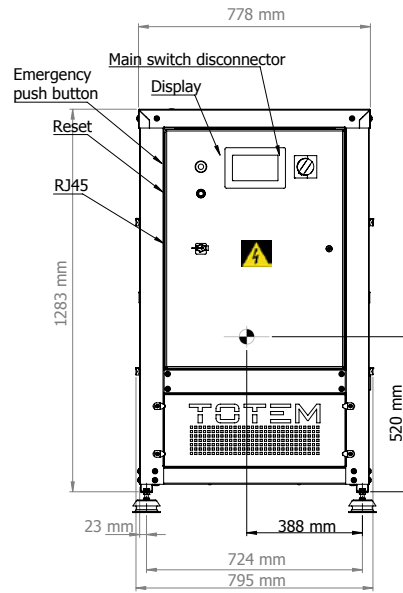
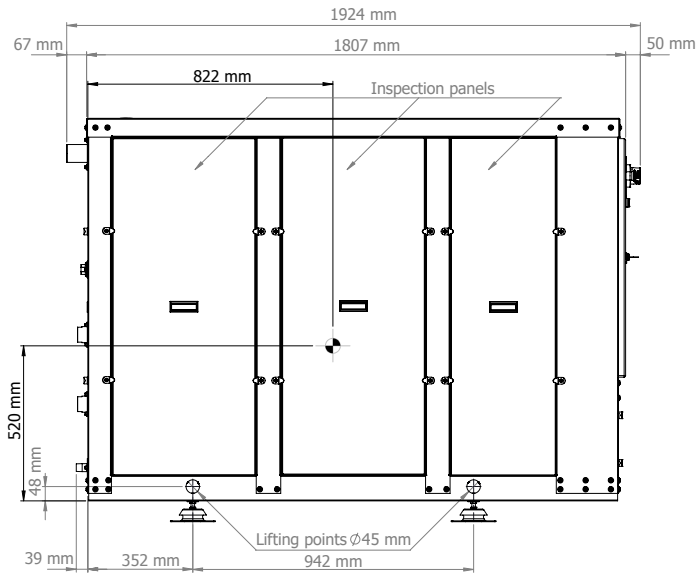



Options and Ancillaries

- System buffer vessels
- Primary and secondary pumps: single or twin head with controls to share load
- Installation kits for the CHP system and buffer vessel accounting for all fittings and components
- Submetering available for gas, electric and heat
- Expansion vessels and pressurisation units
- G59/G83 interface protection panels
- Commissioning and witness testing
- G59 application assistance
- Maintenance plans

Buffer Vessel Options

- Carbon steel buffers from 500L to 10000L
- High and low level flow and return connections
- Extra tappings for use with multiple heat sources, low and high grade heat sources, varying return temperatures or glycol-filled primary loops.
- Vessels up to 5000L can mount up to two high-capacity internal heat exchange coils for use with indirect heat sources
- 5 bar working pressure
- 100mm flexible polyurethane insulation with removable outer PVC jacket
- Bespoke options available upon request



Adveco also offer the following products and services:

- Bespoke system design
 - Maintenance and service packages
 - Buffer tanks
 - Indirect and direct hot water systems
 - Off-site manufacturing of skids and plant rooms
 - Controls systems
 - Packaged plate heat exchangers
 - Solar thermal systems
 - Gas fired heating systems
 - Combined heat & power cogeneration systems
-

Adveco Ltd

Unit 7&8 Armstrong Mall, Southwood Business Park
Farnborough, Hampshire, GU14 0NR

T : 01252 551 540 E : info@adveco.co I : www.adveco.co

Company Reg: 09493966 VAT: GB208979072

