

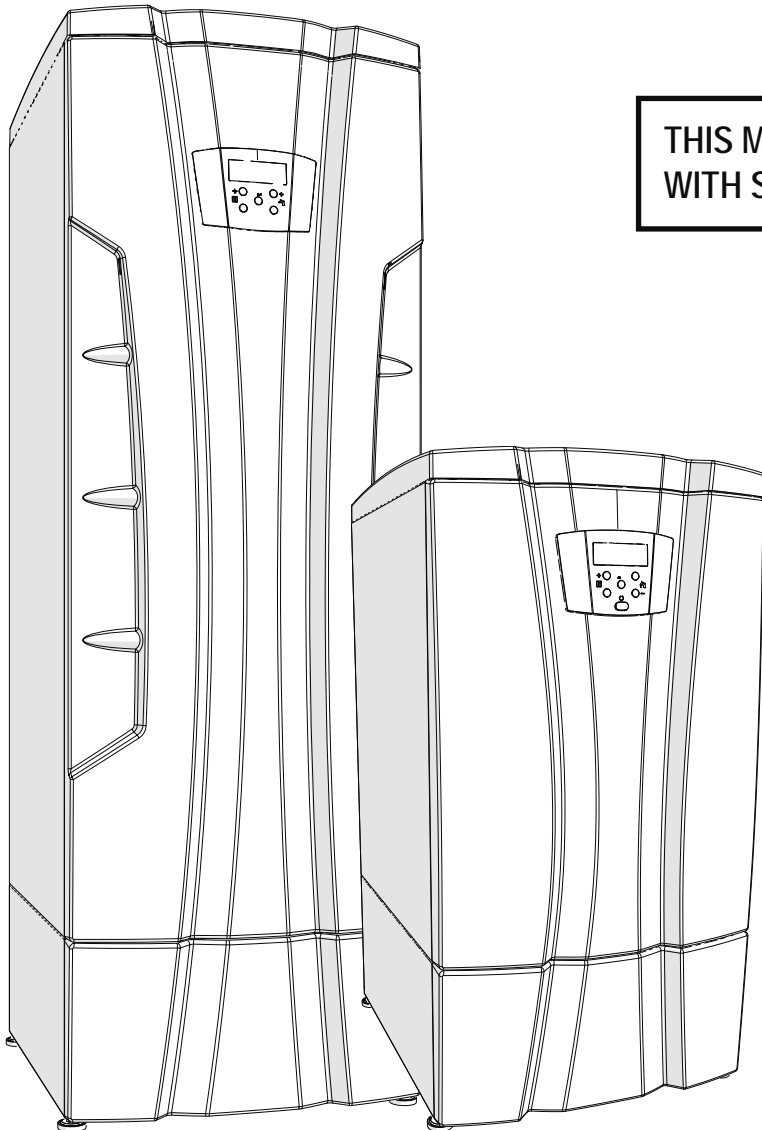

THIS MANUAL APPLY TO HEATERS
WITH SERIAL NUMBER HIGHER THAN 16470167



INSTALLATION, USE AND MAINTENANCE MANUAL

MYDENS FLOOR STANDING
CONDENSING BOILER

AGUADENS FLOOR STANDING
CONDENSING WATER HEATER

70T
140T
210T
280T

SAFETY INSTRUCTIONS



WARNING!!!

FAILURE TO COMPLY WITH THESE PROVISIONS AND REQUIREMENTS MAY COMPROMISE THE SAFETY OF THE UNIT AND CAN RESULT IN A FIRE OR EXPLOSION CAUSING PROPERTY DAMAGE, PERSONAL INJURY, OR DEATH.

Installer: Read all instructions, including this manual, before installing. Perform steps in the order given.

User: This manual is for use only by a qualified heating installer. Refer to the User's Information section for your reference.

Maintenance: at least once a year the user must call a Competent Person for routine maintenance.

If you smell gas

- A - Turn off the gas supply at the gas meter;
- B - Extinguish all naked flames – do not smoke or strike matches;
- C - Do not operate electrical appliances or switches such as a light switch.
- D - Open all doors and windows to ventilate the property.
- E - Call the gas emergency service and follow their directions.

Carbon Monoxide.

Every year deaths and serious injuries occur due to carbon monoxide poisoning. These tragedies are avoidable if certain preventative measures such as the following are undertaken:

- ☞ Ensure that all boilers, water heaters, room heaters, stoves and hobs which burn oil, natural gas, LP gas, coal, peat, wood and wood pallets are serviced regularly. Servicing is needed at least once per year to ensure safety. The service person should be qualified and trained to service the specific types of appliance
- ☞ If an appliance is fitted in a dwelling, then a carbon monoxide detector should always be fitted. There are two types available: a simple detector works like a fire alarm to emit a loud noise and flashing light if carbon monoxide is detected or a more sophisticated version which will also switch off the appliance to provide more safety.

Explosive or highly flammable products

Do not store or use explosive or highly flammable materials such as paper, solvents, paints, etc...in the same room where the appliance is installed.

If you can smell combustion products

1. - Switch the appliance off.
2. - Ventilate the room.
3. - Call a professionally qualified technician.

Competent Person: Competent Person is an individual with specific, technical training in space heating systems, domestic hot water systems, fuel gas systems and electrical systems. This individual must have the legally required qualifications.

Installation and Modifications: Only a Competent Person must carry out the installation and calibration of the heater. Never modify the heater or its flue gas carrying components in any way. This heater must be properly vented.

Flue gas/air intake:

- You are only permitted to operate this appliance with the combustion air/flue gas system that has been specifically designed and approved.
- Do not obstruct the air intake or vent pipe terminals.
- If heater installation is provided as replacement heater, DO NOT connect new heater to an existing flue system, unless the flue system designer has been consulted.
- Do not restrict or seal any air intake or outlet openings (terminals).

Hazards and Your Safety - Hot Water Can Scald! Water temperature over 52°C can cause severe burns instantly, or death from scalds. Children, the disabled, and the elderly are at highest risk of being scalded; see instruction manual before setting temperature at heater! Feel water before bathing or showering.

Defects: If you find any defects, you must inform the owner of the system of the defect and the associated hazard in writing.

When servicing heater, to avoid electric shock, disconnect electrical supply before performing maintenance.

When servicing heater, to avoid severe burns, allow heater to cool before performing maintenance.

Label all wires prior to disconnection when servicing controls. Wiring errors can cause improper and dangerous operation. Verify proper operation after servicing.

Correct Use:

This heater must only be used for the purpose for which it has been expressly designed: Heating of water for closed circuit systems for central heating.

Do not use this appliance if any part has been under water. Immediately call a competent person to inspect the appliance and to replace any part of the control system and any gas control, which has been under water. Ensure the heater and its controls are protected from dripping or spraying water during normal operation or service.

Only use the heater in the combinations and with the accessories and spares listed in this manual.

For safety and environmental reasons, the packing materials must be properly disposed of. Any replaced part or packaging should never be left within the reach of children.

CAUTION!!! FAILURE TO COMPLY WITH THESE PROVISIONS AND REQUIREMENTS MAY COMPROMISE THE SAFETY OF THE UNIT AND CAN RESULT IN A FIRE OR EXPLOSION CAUSING PROPERTY DAMAGE, PERSONAL INJURY, OR DEATH.

Installation location: The heater must be located in an area where leakage of the tank or connections will not result in damage to the area adjacent to the heater or to lower floors of the structure. When such locations cannot be avoided, it is recommended that a suitable drain pan, adequately drained, be installed under the heater. The pan must not restrict combustion air flow.

Installation location: The heater must be installed on a non-combustible surface.

In the event of a breakdown and/or malfunction of the heater, turn off the unit and do not make any attempt to repair it. The heater must be serviced by a Competent Person using original spare parts.

Installation, modifications

- ☞ Seal the adjustment devices after every calibration.
- ☞ In agreement with the provisions for use, the user must keep the installation in good working order and guarantee reliable and safe operation of the appliance.
- ☞ We also highlight the importance of an annual scheduled maintenance contract with a professionally qualified technician.
- ☞ The end user must have maintenance performed on the appliance only by competent person in accordance with this manual and in full compliance with both local and national standards.
- ☞ Before performing any cleaning or maintenance, disconnect the appliance from the mains power supply.
- ☞ After any cleaning or maintenance, before reconnecting the power supply, make sure that all internal parts are properly dry.

☞ This appliance is not intended for use by persons (including children) with reduced physical and sensory conditions or lack of experience and knowledge, unless they have been given supervision or instruction concerning use of the appliance by a person responsible for their safety.

☞ This manual is an integral and essential part of the product and must be kept carefully by the user, for possible future consultation. If the appliance must be transferred or if you should move and leave the unit to another user, always ensure that this manual remains with the new user and/or installer.

Do not use “homemade cures” or “heater patent medicines”. Serious damage to the heater, personnel, and/or property may result.

Do not use petroleum-based cleaning or sealing compounds in the heater system. Gaskets and seals in the system may be damaged. This can result in substantial property damage.

Technical drawings

All drawings in this manual relating to electrical wiring, hydraulic and gas layouts are purely indicative. The external services such as electrical cable types and sizes, water pipes and gas pipes must always be checked by a professionally qualified technician or engineer to verify compliance with all relevant standards, Laws and codes of good practice.

NOTICE!

Local approval of the flue system and the condensate connection to the public sewer system may be required.

The local building regulations stipulating the installation rules at the time of installation.

When calling or writing about the heater – Please have the heater model and serial number from the heater rating plate.

Any claims for damage or shortage in shipment must be filed immediately against the transportation company by the consignee.

The manufacturer declines all liability, contractual or otherwise (warranty included), for any damage to people, animals property or this same appliance, caused by:

- a) - incorrect installation;
- b) - failure to comply with this or any other instruction provided by the manufacturer;
- c) - failure to comply with the applicable local and/or national regulations in force;
- d) - incorrect use of this appliance
- e) - inadequate or incorrect service
- f) - inadequate or incorrect maintenance.

INDEX

SAFETY INSTRUCTIONS	2
1 - CODE REQUIREMENTS	7
1.1 - National laws and regulations	7
2 - GENERAL INFORMATION	8
2.1 - Introduction	8
2.2 - Overview of the models	8
2.3 - Included accessories	9
2.4 - Manufacturer	9
2.5 - Meaning of the symbols used	9
2.6 - Maintenance	9
3 - MAIN COMPONENTS	10
4 - OPERATION	18
4.1 - Operation and intended use	22
4.1.1 - Boiler operation and intended use	22
4.1.2 - Water heater operation and intended use	22
4.1.3 - Wide range of modulation and maximum performance	22
4.1.4 - Main circuit pump	23
4.1.5 - Heating circuit pump	23
4.1.6 - Domestic hot water circuit pump	23
4.1.7 - Hydraulic separator	23
4.1.8 - Boiler domestic hot water production	23
4.1.9 - System types	23
4.2 - Precautions when installing	23
4.3 - Anti-legionella	23
5 - INSTALLATION - Installation site	24
5.1 - Choosing the installation site	24
5.1.1 Requirements for proper ventilation	25
5.1.2 - Preventing combustion air contamination	25
6 - INSTALLATION - Setup	26
6.1 - Setup	26
6.1.1 - Moving the appliance	26
6.1.2 - Opening the package	26
6.1.3 - Lifting the appliance	26
7 - INSTALLATION - Minimum distances to respect	27
7.1 - Dimensions and minimum distances to respect	27
8 - INSTALLATION - Dimensions and centre distances - Boiler	28
9 - INSTALLATION - Dimensions and centre distances - Water heater	30
10 - INSTALLATION - Hydraulic connections - boiler	32
10.1 - Boiler gas and hydraulic connections	32
10.2 - Boiler safety valve (installer's responsibility)	32
10.3 - Examples of boiler installations	32
10.4 - Expansion tank connection	34
10.5 - Supply and return	34
10.6 - Boiler water supply	34
10.6.1 - Recommendations on the characteristics of the water used in the system	34
10.6.2 - For the system to operate properly, you must make sure that:	34
10.6.3 Treating water in heating systems for commercial use	35
10.7 - Draining the boiler heating circuit	35
10.8 - Boiler low temperature (or floor) systems	35
10.9 - Manifold sensor	35
10.10 - Characteristic curve of the boiler head loss	36
11 - INSTALLATION - Hydraulic connections - water heater	37
11.1 - Water heater gas and hydraulic connections	37
11.2 - Water heater safety valve (installer's responsibility)	37
11.3 - Examples of water heater installations	37
11.4 - Expansion vessel	38
11.5 - Circulation pump	38
11.6 - System sizing	38
11.7 - Precautions against burns	39
11.8 - Minimum and maximum water flow rate in the water heater	39
12 - INSTALLATION - Eliminating condensate	40
12.1 - Condensate drain	40

INDEX

13 - INSTALLATION - Electrical connections	41
13.1 - Electrical connections: general information	41
13.1.1 - Connecting the power cable	41
13.1.2 - Choosing the room thermostat/time-programmable thermostat	42
13.1.3 - Connecting the room thermostat/time-programmable thermostat	42
13.1.4 - Installing the external temperature sensor	42
13.1.5 - 885 IF board connection	43
13.1.6 - Alarm contact	43
13.2 - Connecting boiler to the storage tank	43
13.2.1 - D.H.W. production priority	43
13.3 - Connecting water heater to the storage tank	44
13.4 - Connecting cascade appliances	47
14 - INSTALLATION - Air intake and flue exhaust ducts	49
14.1 - Flue exhaust and combustion air intake duct	49
14.1.1 - B23 suction/discharge type	49
14.1.2 - Split system	50
15 - COMMISSIONING	51
15.1 - Commissioning	51
15.1.1 - Filling the condensate drain siphon	51
15.1.2 - Filling the heating system	51
15.2 - General warnings on the gas power supply	52
15.3 - Type of gas for which the appliance is regulated.	52
15.4 - Converting 70T model appliances from one type of gas to another	53
15.5 - Converting appliance models from 140T to 280T from one type of gas to another	55
15.6 - Ignition	57
15.6.1 - Boiler ignition	57
15.6.2 - Water heater ignition	57
15.7 - Checking the supply gas pressure and any adjustments	57
15.8 - Checking the CO ₂ seal and any adjustments	58
15.8.1 - Checking the CO ₂ seal and any adjustments on 70T model appliances	58
15.8.2 - Checking the CO ₂ seal and any adjustments on appliance models from 140T up to 280T	59
15.9 - Checking appliance heat input	59
15.10 - Minimum water flow rate	59
15.11 - User instructions	59
16 - USE	60
16.1 - Checking water pressure	60
16.1.1 - Checking boiler water pressure	60
16.1.2 - Checking water heater system pressure	60
16.2 - General information	61
16.3 - Display	61
16.4 - Ignition and shutdown procedure	61
16.5 - Direct water heater temperature adjustment	61
16.6 - Indirect domestic hot water adjustment	61
16.7 - Boiler heating adjustment	61
16.8 - Thermostat type heating adjustment	61
16.9 - Temperature compensated operation	62
16.9.1 - Climatic adjustment: setting the parameters	62
16.9.2 - Temperature compensated operation: switching the heating system on and off	62
16.10 - Timing of the various functions	62
16.11 - Pump anti-locking	62
16.12 - Antifreeze protection	62
16.13 - Energy Saving	62
16.14 - "User menu"	64
16.15 - "Installer menu"	65
16.16 - Diagnostics	66
16.16.1 - Diagnostics: "Loc" lock	67
16.16.2 - Diagnostics: "E" errors	69
17 - MAINTENANCE	71
17.1 - General warnings	71
17.1.1 - Gas leak check	71
17.1.2 - Making sure the air intake and flue exhaust ducts are in good conditions	71
17.1.3 - Checking the system water pressure	71
17.1.4 - Checking the ignition and detection electrodes	71

INDEX

17.2 - Disassembling the casing and accessing the inner components.....	72
17.3 - Disassembling the burner fan unit.....	72
17.4 - Cleaning the burner and the primary exchanger, flue gas side.....	73
17.4.1 - Thermal insulations.....	75
17.5 - Positioning the ignition and ionisation electrodes properly	75
17.6 - Cleaning the air intake filter.....	76
17.7 - Condensate drain system maintenance and cleaning	76
17.8 - Connecting the Display to the other burners.....	77
17.9 - How to move a control board	78
17.10 - Emptying the appliance.....	80
17.11 - Minimum and maximum output heat	80
17.12 - Checking the ionisation current.....	80
17.13 - Checking combustion performance.....	80
17.14 - Temperature and water measurement sensors.....	81
17.15 - External temperature sensor.....	81
17.16 - 70T models multi-line wiring diagram.....	82
17.17 - 140T,210T and 280T models multi-line wiring diagram.....	84
18 - TECHNICAL FEATURES	88
18.1 - TECHNICAL FEATURES MYDENS.....	88
18.2 - TECHNICAL FEATURES AGUADENS	92
19 - FORCED MENU.....	96
20 - CONTROL MENU DIAGRAM.....	98
21 - BOILER OPERATION SEQUENCE	99
22 - WATER HEATER OPERATION SEQUENCE.....	100
23 - CE DECLARATION OF CONFORMITY	101
24 - ErP PRODUCT FICHE MYDENS	102
25 - ErP PRODUCT FICHE AGUADENS	104

1 - CODE REQUIREMENTS

1.1 - National laws and regulations

All the gas appliances must be installed by a competent person, in accordance with the relevant clauses of applicable standards and recommendations. These include but may not be limited to the following:

- I.S. 813 Domestic gas installations.
- I.S. 820 Non-Domestic gas installations.
- BS 7671:2008 + A3:2015 - Requirements for Electrical Installations. IET Wiring Regulations..
- BS 6644:2011 - Specification for the installation and maintenance of gas-fired hot water boilers of rated inputs between 70 kW (net) and 1.8 MW (net) (2nd and 3rd family gases).
- BS 6891:2015 - Specification for the installation and maintenance of low pressure gas installation pipework of up to 35 mm (R1 1/4) on premises.
- BS 5482-1:2005 - Code of practice for domestic butane and propane gas burning installations. Installations at permanent dwellings, residential park homes and commercial premises, with installation pipework sizes not exceeding DN 25 for steel and DN 28 for corrugated stainless steel or copper.
- BS 8558:2011 - Guide to the design, installation, testing and maintenance of services supplying water for domestic use within buildings and their curtilages. Complementary guidance to BS EN 806;
- IGEM UP 10 4th Edition;
- Building regulations issued by the Department of the Environment and Building Standards Regulations.
- Gas safety (Installation and Use) Regulations current issue.
- Health and Safety at Work Act 1974.
- All relevant Building Regulations.
- Local Water Byelaws.
- Water Regulations.
- Health & Safety legislation.

Failure to install this appliance correctly could lead to prosecution. It is in your own interest and in the interest of safety to ensure that the law is complied with. Manufacturer's instructions must not be interpreted as over-riding statutory obligations under any circumstances.



2 - GENERAL INFORMATION

2.1 - Introduction

Congratulations! You have purchased truly one of the best products on the market. Every single part is proudly designed, built, tested and assembled at the COSMOGAS plants, thereby ensuring the best quality control.

2.2 - Overview of the models

XXXXDENS XXXTXX

v = Appliance with 2-way valves
s = Appliance with stainless steel manifold
sv = Appliance with 2-way valves and stainless steel manifold
c = Appliance with carbon steel manifold
cv = Appliance with 2-way valve and carbon steel manifold









“70T” = Floor standing appliance with 70kW maximum heat output;
“140T” = Floor standing appliance with 140kW maximum heat output;
“210T” = Floor standing appliance with 210kW maximum heat output;
“280T” = Floor standing appliance with 280kW maximum heat output;

“MYDENS” = Indoor gas condensing boiler with low emission pre-mixed burner.
“AGUADENS” = Indoor gas condensing water heater with low emission pre-mixed burner.

2 - GENERAL INFORMATION

2.3 - Included accessories

The appliance is supplied with the following accessories:

Amount No.	Description	Code	Figure
1	70T, 140T, 210T AND 280T Natural GAS - LPG Propane CONVERSION KIT.	62630198	
1	10K SENSOR D6X45 L=2500 T	62110071	
1	EXTERNAL TEMPERATURE SENSOR	62110067	
4	ADJUSTABLE FEET	60805006	
1	10KG SACK OF CONDENSATE NEUTRALISER GRANULES	62801022	
1	1P NPT - 1P GAS REDUCTION	Only in 140T model	
	1P1/4 NPT - 1P1/4 GAS REDUCTION	Only in 210T and 280T models	
2	2P NPT - 1P1/2 GAS REDUCTION	Only in 140T model	
2	EN 1092-1-13 DN65 PN16 NPT FLANGE	Only in 210T and 280T models	

2.4 - Manufacturer

COSMOGAS srl
Via L. da Vinci 16
47014 - Meldola (FC) Italy
Tel. 0543 498383
Fax. 0543 498393
www.cosmogas.com
info@cosmogas.com

2.5 - Meaning of the symbols used



ATTENTION !!!

Danger of electrical shock. Failure to follow these warnings can compromise proper appliance operation or cause serious harm to persons, animals or things.



ATTENTION !!!

General danger. Failure to follow these warnings can compromise proper appliance operation or cause serious harm to persons, animals or things.

 Important instruction symbol

2.6 - Maintenance

It is advisable to follow scheduled annual appliance maintenance for the following reasons:

- to maintain high output and manage the heating system affordably (low fuel consumption);
- to reach high work safety;
- to keep the level of fuel environmental compatibility high;

Offer your customers a periodic maintenance contract.

3 - MAIN COMPONENTS

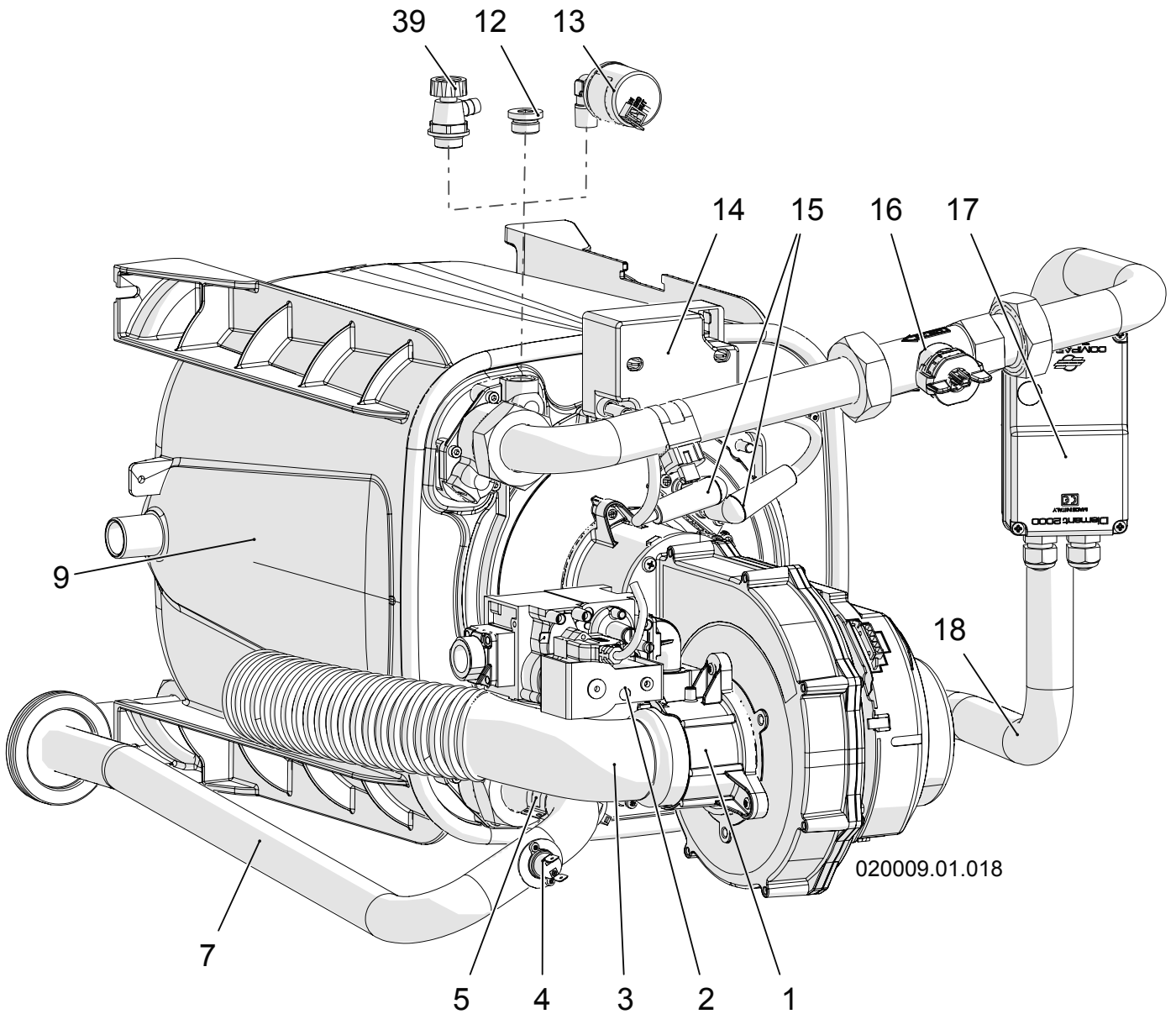

- | | |
|----------------------------------|---|
| 1 - Air/gas mixing unit | 11 - ----- |
| 2 - Gas valve | 12 - Plug (not present) |
| 3 - Air inlet manifold | 13 - Water pressure sensor (present on the MASTER burner 1) |
| 4 - Hot water safety thermostat | 14 - Spark generator |
| 5 - Hot water temperature sensor | 15 - Ignition cables |
| 6 - ----- | 16 - Water flow rate measuring device |
| 7 - Hot water supply pipe | 17 - Motorised 2-way valve (on request) |
| 8 - ----- | 18 - Water inlet pipe |
| 9 - Heat exchanger | 39 - Air bleed valve (present on all slave burners) |
| 10 - ----- | |

Figure 3-1 - Components inside

3 - MAIN COMPONENTS

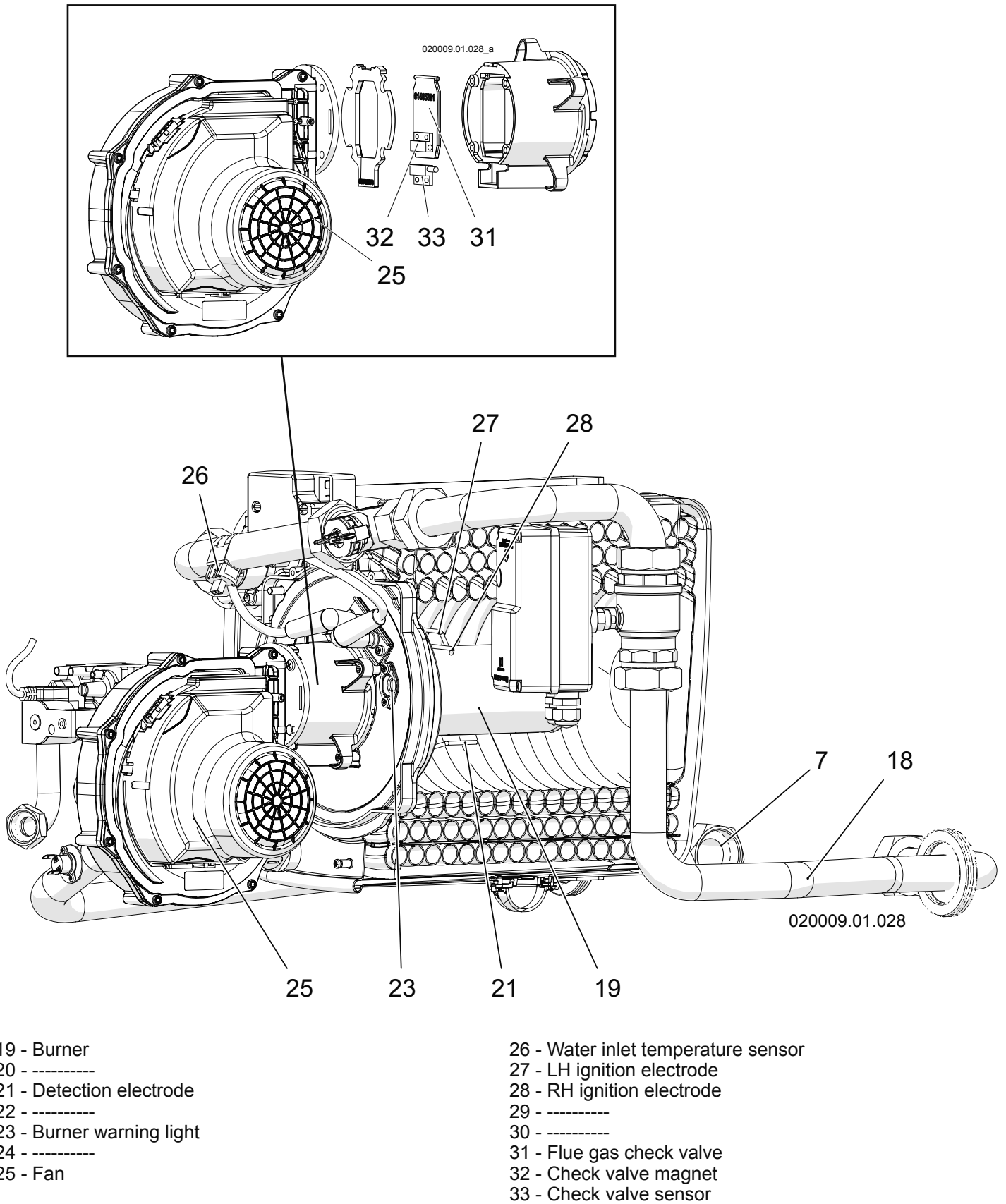
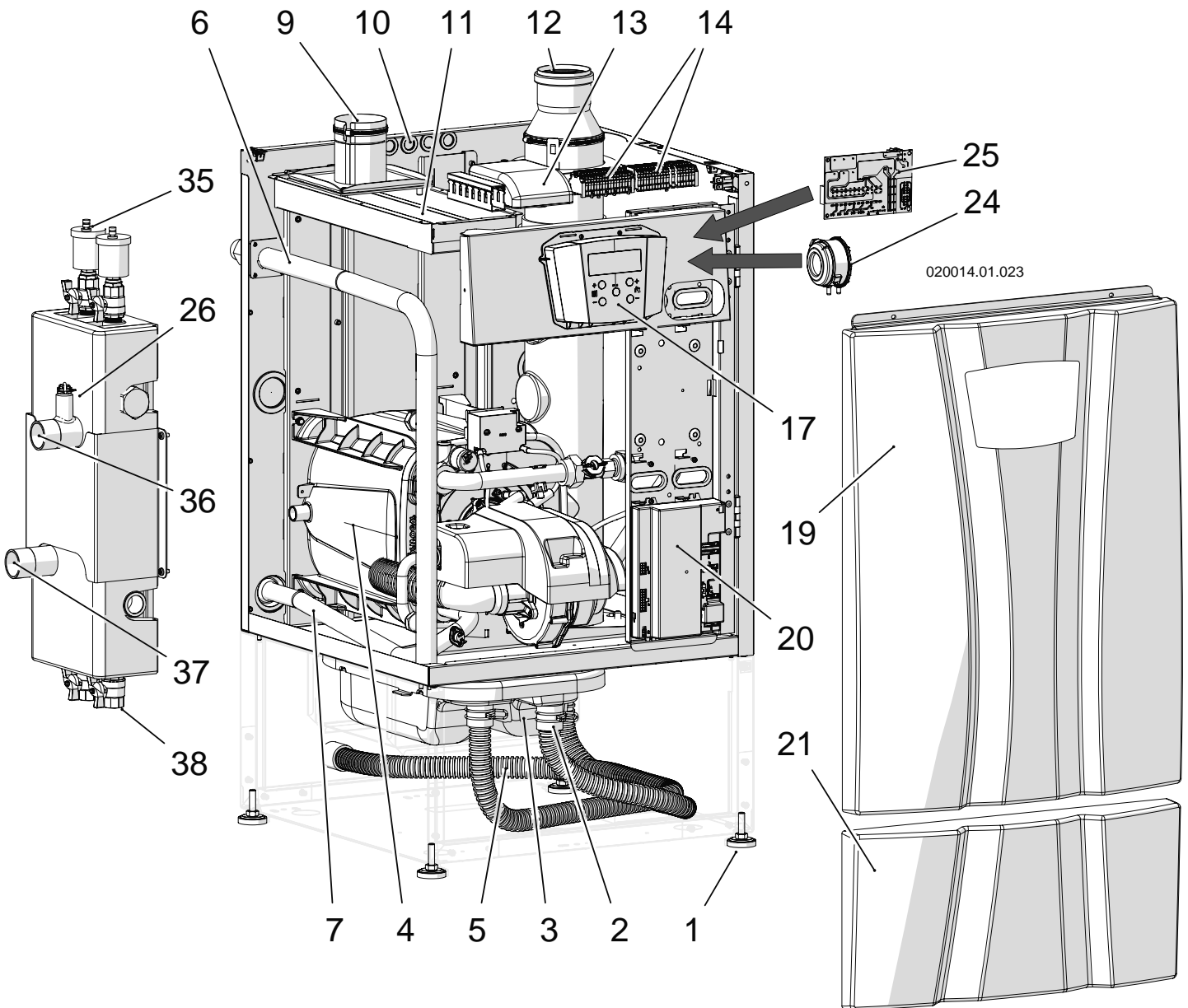

Figure 3-2 - Components inside

3 - MAIN COMPONENTS



- 1 - Adjustable feet
- 2 - Flue exhaust condensate drain pipe
- 3 - Condensate neutraliser
- 4 - Burner "1" (MASTER)
- 5 - Condensate drain pipe
- 6 - Gas inlet pipe
- 7 - Hot water supply pipe
- 9 - Air intake
- 10 - Electrical wire passage
- 11 - Air intake filter
- 12 - Flue exhaust
- 13 - 885 IF board

- 14 - Electrical connections
- 15 - -----
- 16 - -----
- 17 - Control panel
- 19 - Upper front casing
- 20 - "Burner 1" command and control board
- 21 - Lower front casing
- 24 - Pressure switch against discharge clogging
- 25 - Wiring diagram
- 35 - Automatic air vent
- 36 - Water supply connection
- 37 - Water return connection
- 38 - Drain valves

Figure 3-3 - Components inside 70T model

3 - MAIN COMPONENTS

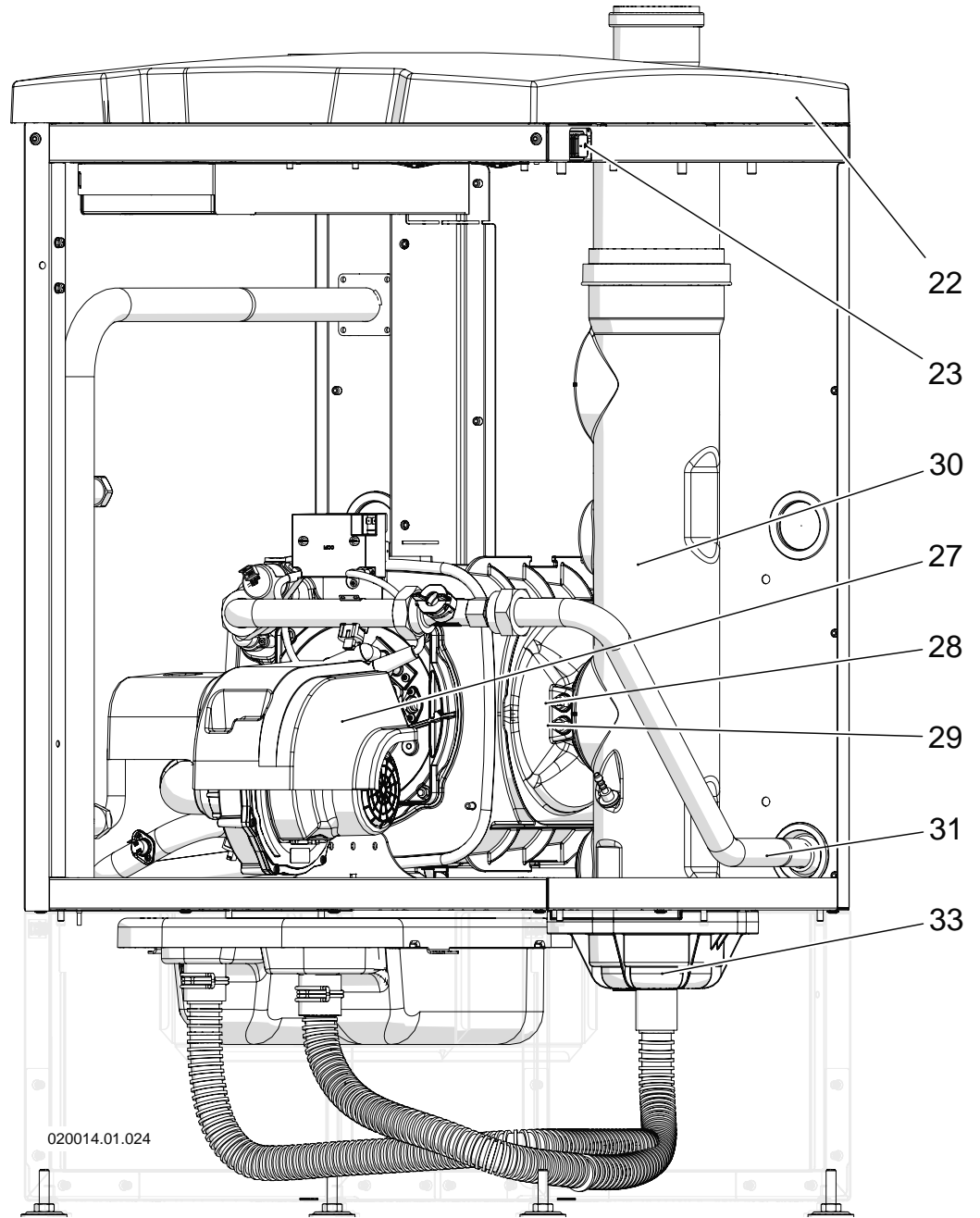

- 22 - Upper covering
- 23 - Main ON/OFF switch
- 27 - Fan covering
- 28 - Flue exhaust temperature safety fuse
- 29 - Flue exhaust temperature sensor

- 30 - Flue exhaust manifold
- 31 - Water inlet pipe
- 32 - -----
- 33 - Condensate level sensor
- 34 - -----

Figure 3-4 - Components inside 70T model

3 - MAIN COMPONENTS

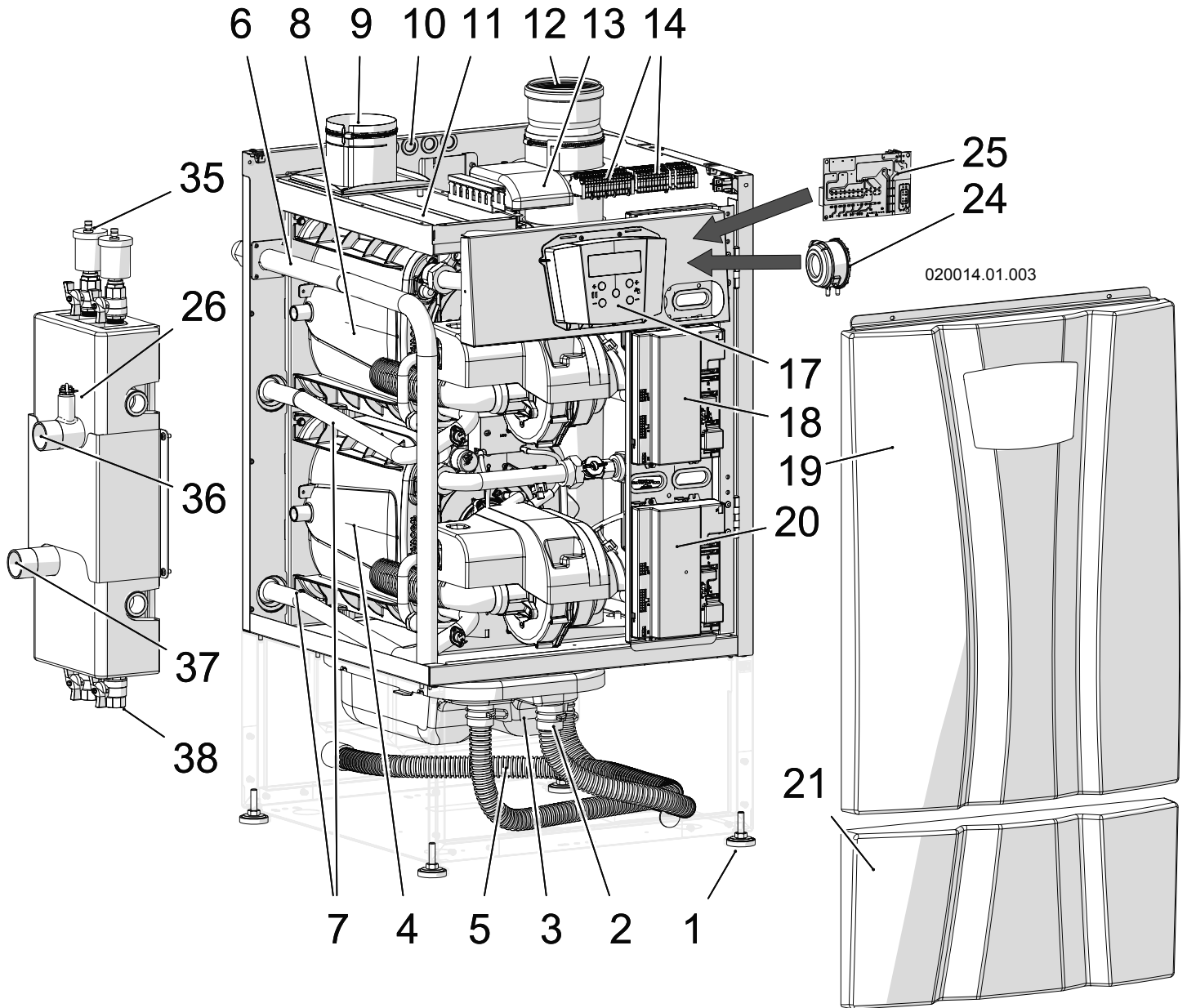

- 1 - Adjustable feet
- 2 - Flue exhaust condensate drain pipe
- 3 - Condensate neutraliser
- 4 - Burner "1" (MASTER)
- 5 - Condensate drain pipe
- 6 - Gas inlet pipe
- 7 - Hot water supply pipe
- 8 - Burner "2" (SLAVE)
- 9 - Air intake
- 10 - Electrical wire passage
- 11 - Air intake filter
- 12 - Flue exhaust
- 13 - 885 IF board
- 14 - Electrical connections

- 15 - -----
- 16 - -----
- 17 - Control panel
- 18 - "Burner 2" command and control board
- 19 - Upper front casing
- 20 - "Burner 1" command and control board
- 21 - Lower front casing
- 24 - Pressure switch against discharge clogging
- 25 - Wiring diagram
- 26 - Water outlet manifold temperature sensor
- 35 - Air bleed valve
- 36 - Water outlet
- 37 - Water inlet
- 38 - Drain cock

Figure 3-5 - Components inside 140T model

3 - MAIN COMPONENTS

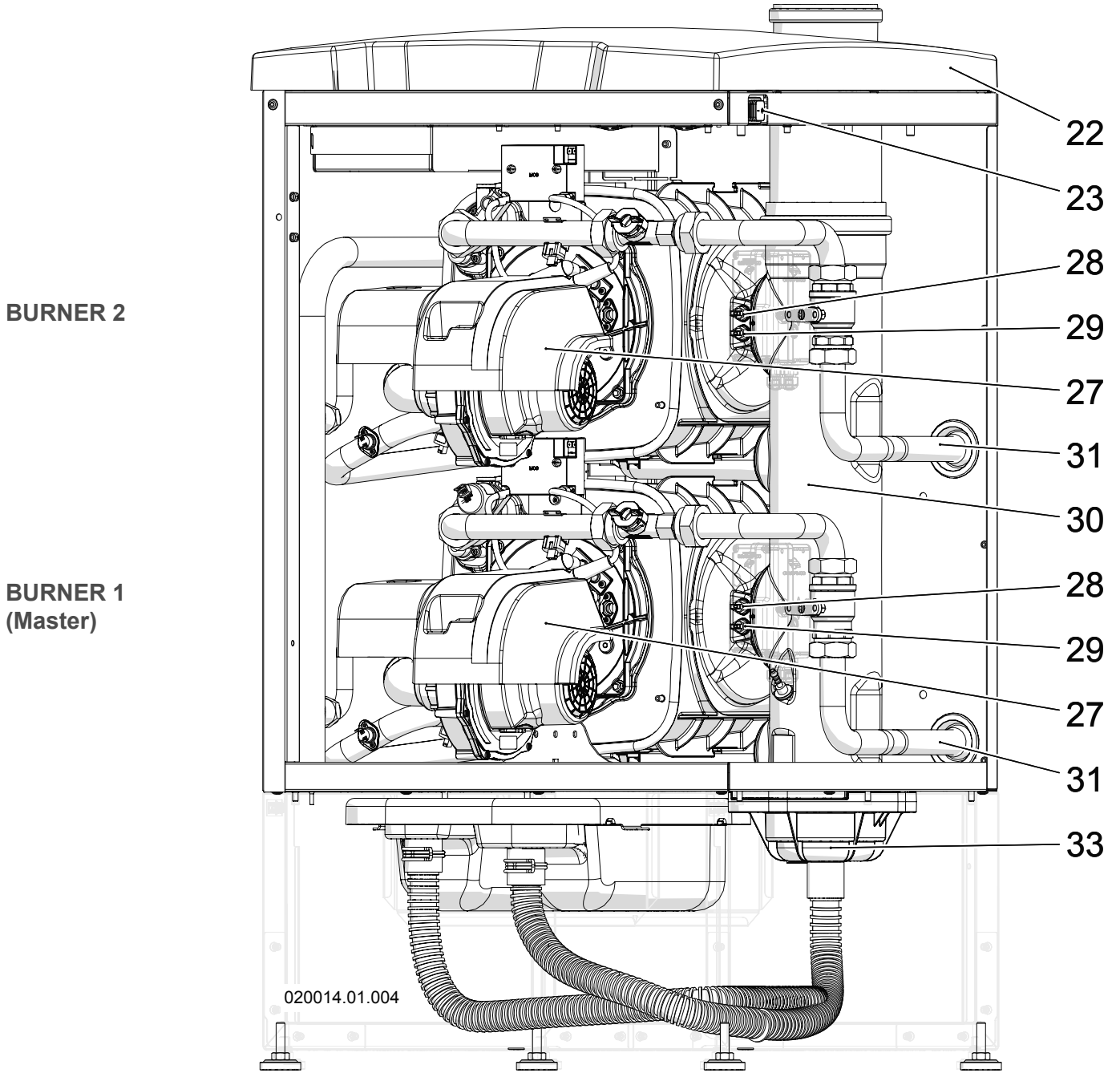

- 22 - Upper covering
- 23 - Main ON/OFF switch
- 26 - Water general outlet temperature sensor
- 27 - Fan covering
- 28 - Flue exhaust temperature safety fuse
- 29 - Flue exhaust temperature sensor

- 30 - Flue exhaust manifold
- 31 - Water inlet pipe
- 32 - -----
- 33 - Condensate level sensor
- 34 - -----

Figure 3-6 - Components inside 140T model

3 - MAIN COMPONENTS

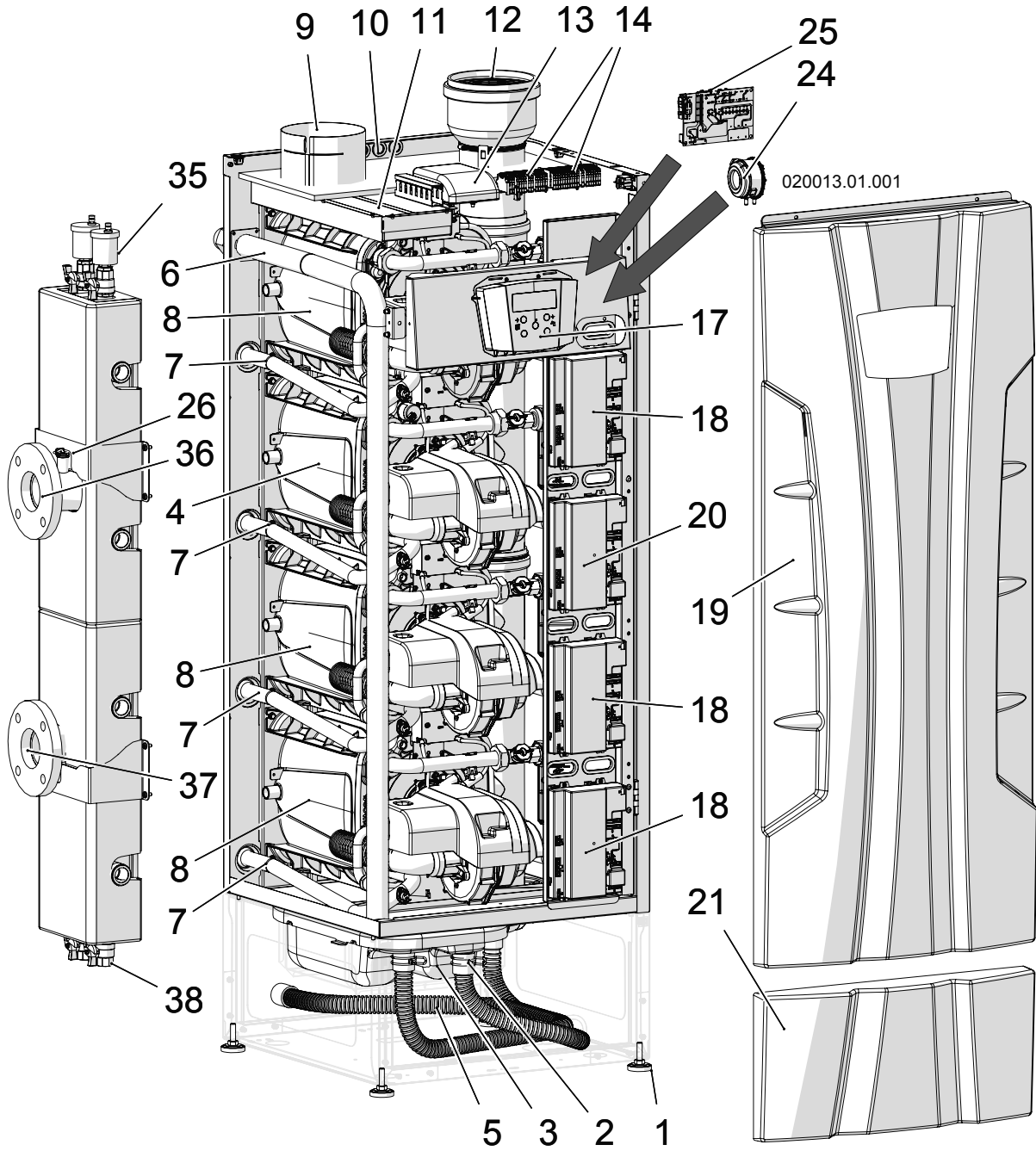

- 1 - Adjustable feet
- 2 - Flue exhaust condensate drain pipe
- 3 - Condensate neutraliser
- 4 - Burner "1" (MASTER)
- 5 - Condensate drain pipe
- 6 - Gas inlet pipe
- 7 - Hot water supply pipe
- 8 - Burner "2"- "3"- "4" (SLAVE)
- 9 - Air intake
- 10 - Electrical wire passage
- 11 - Air intake filter
- 12 - Flue exhaust
- 13 - 885 IF board
- 14 - Electrical connections

- 15 - -----
- 16 - -----
- 17 - Control panel
- 18 - Burner "2"- "3"- "4" command and control board
- 19 - Upper front casing
- 20 - Burner "1" command and control board
- 21 - Lower front casing
- 24 - Pressure switch against discharge clogging
- 25 - Wiring diagram
- 26 - Water outlet manifold temperature sensor
- 35 - Air bleed valve
- 36 - Water outlet
- 37 - Water inlet
- 38 - Drain cock

Figure 3-7 - Components inside 210T and 280T models

3 - MAIN COMPONENTS

BURNER 2
(Not present on 180T
and 210T models)

BURNER 1
(Master)

BURNER 3

BURNER 4

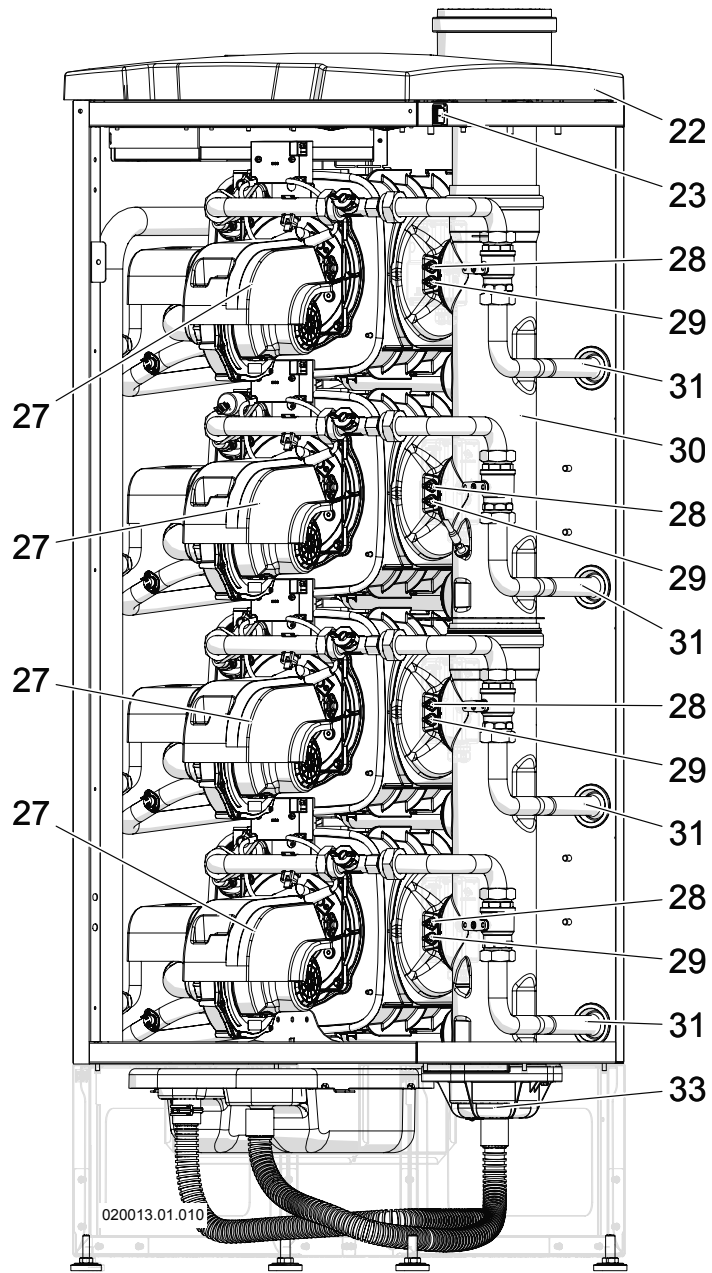

- 22 - Upper covering
- 23 - Main ON/OFF switch
- 27 - Fan covering
- 28 - Flue exhaust temperature safety fuse
- 29 - Flue exhaust temperature sensor

- 30 - Flue exhaust manifold
- 31 - Water inlet pipe
- 32 - -----
- 33 - Condensate level sensor
- 34 - -----

Figure 3-8 - Components inside 210T and 280T models

4 - OPERATION

Figure 4-1 key:

- 1 - Air intake
- 2 - Flue exhaust
- 3 - Air bleed valve
- 4 - Sealed chamber
- 6 - Water outlet temperature safety thermostat
- 7 - Water outlet temperature sensor
- 8 - Water pressure measuring device
- 9 - Flue exhaust temperature sensor
- 10 - Flue exhaust temperature safety fuse
- 12 - Pre-mixed burner
- 13 - Ignition electrodes
- 14 - Spark generator
- 15 - Water inlet temperature sensor
- 16 - Fan
- 17 - Flue gas non-return valve
- 20 - Gas valve
- 22 - Detection electrode
- 24 - CRV Heat exchanger
- 25 - Water outlet
- 26 - Water inlet
- 27 - Gas inlet
- 28 - Pressure switch against discharge clogging
- 29 - Condensate level sensor
- 30 - Condensate drain
- 31 - Condensate drain siphon
- 36 - Condensate neutraliser
- 47 - Water flow rate measuring device

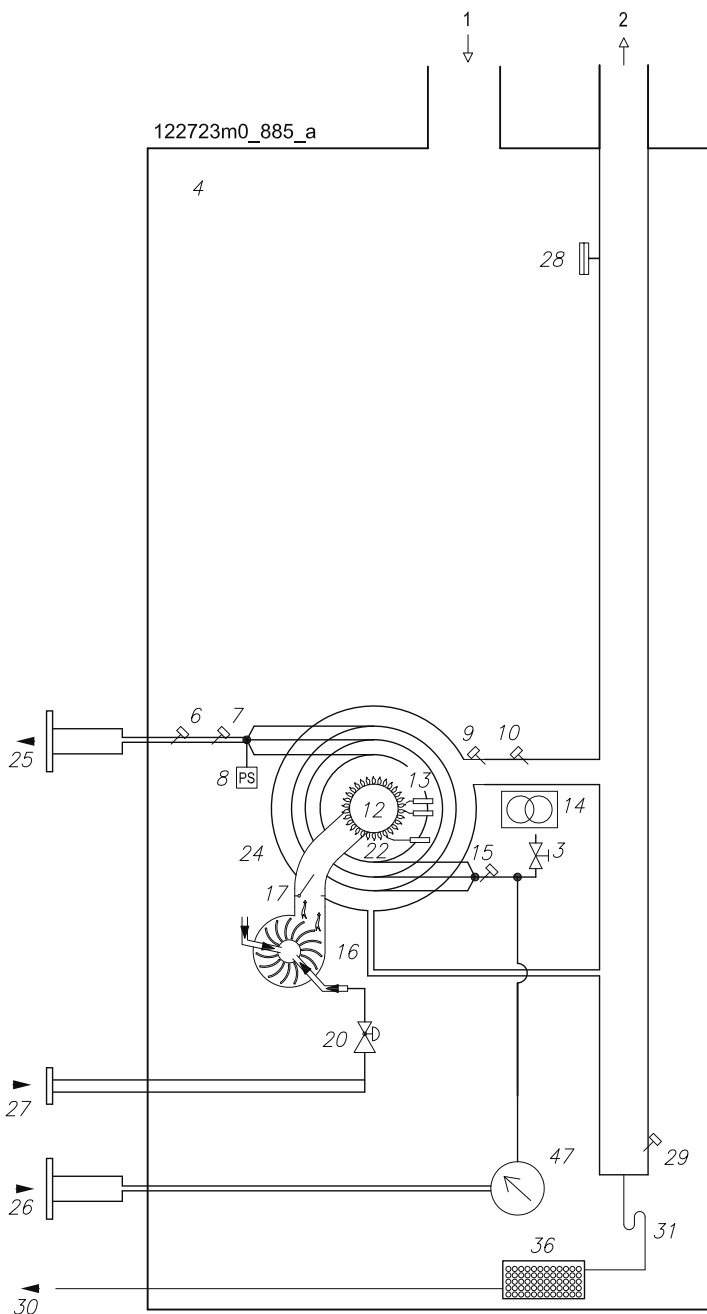

Figure 4-1 - 70T model functional hydraulic diagram

4 - OPERATION

Figure 4-2 key:

- 1 - Air intake
- 2 - Flue exhaust
- 3 - Air bleed valve
- 4 - Sealed chamber
- 6 - Water outlet temperature safety thermostat
- 7 - Water outlet temperature sensor
- 8 - Water pressure measuring device
- 9 - Flue exhaust temperature sensor
- 10 - Flue exhaust temperature safety fuse
- 12 - Pre-mixed burner
- 13 - Ignition electrodes
- 14 - Spark generator
- 15 - Water inlet temperature sensor
- 16 - Fan
- 17 - Flue gas non-return valve
- 20 - Gas valve
- 22 - Detection electrode
- 24 - CRV Heat exchanger
- 25 - Water outlet
- 26 - Water inlet
- 27 - Gas inlet
- 28 - Pressure switch against discharge clogging
- 29 - Condensate level sensor
- 30 - Condensate drain
- 31 - Condensate drain siphon
- 33 - Manifold outlet temperature sensor
- 36 - Condensate neutraliser
- 47 - Water flow rate measuring device
- 48 - Motorised 2-way valve (on request)

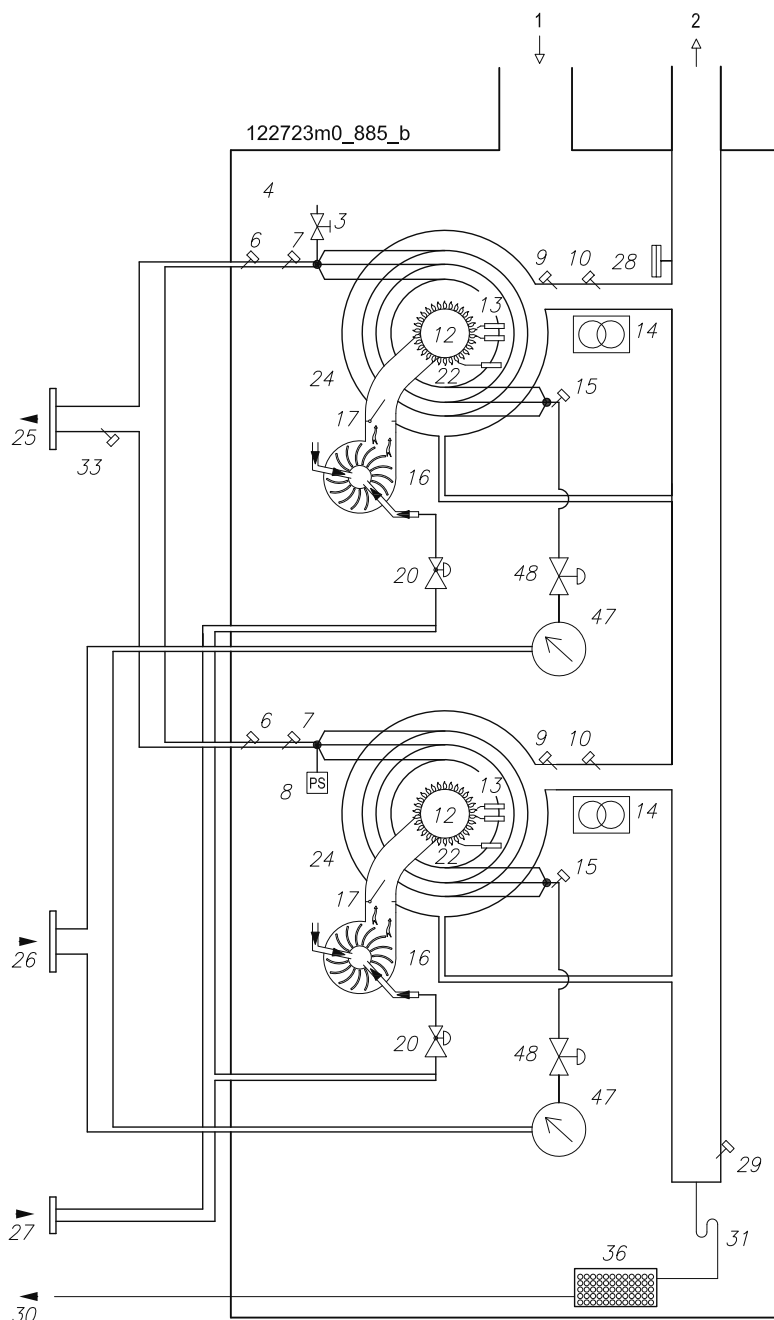

Figure 4-2 - 140T model functional hydraulic diagram

4 - OPERATION

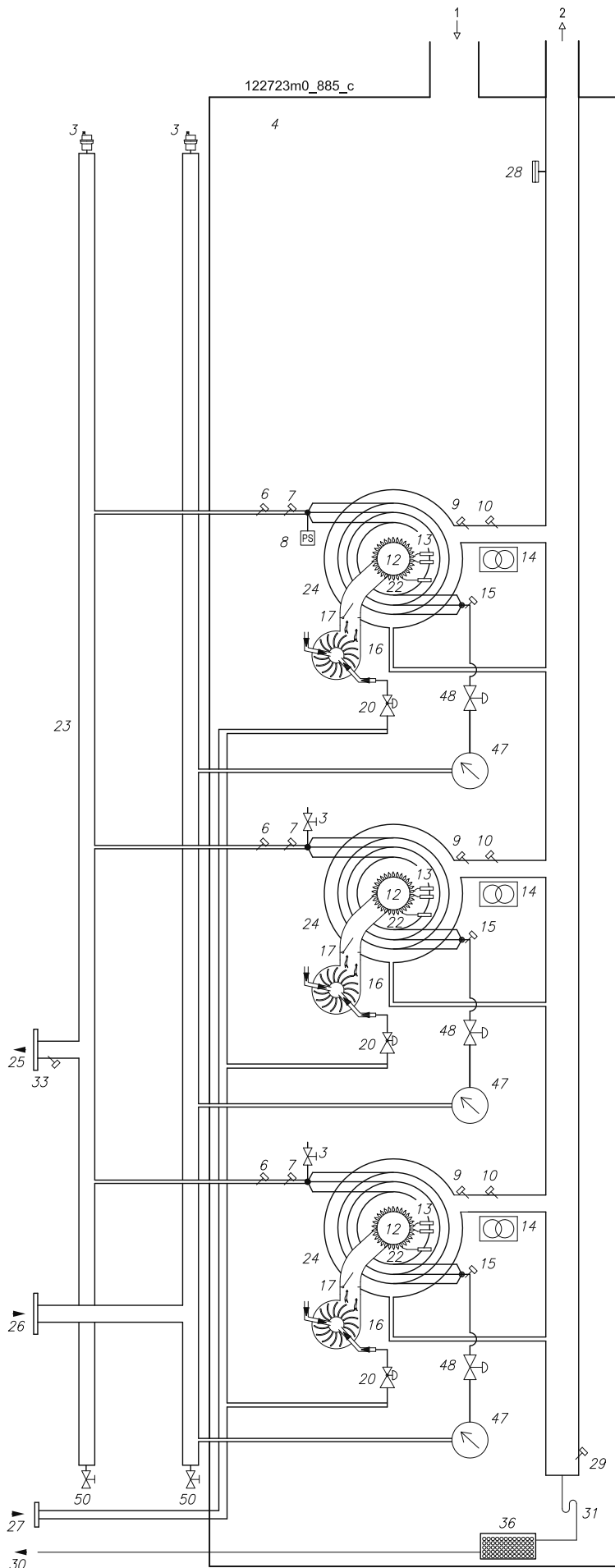

Figure 4-3 key:

- 1 - Air intake
- 2 - Flue exhaust
- 3 - Air bleed valve
- 4 - Sealed chamber
- 6 - Water outlet temperature safety thermostat
- 7 - Water outlet temperature sensor
- 8 - Water pressure measuring device
- 9 - Flue exhaust temperature sensor
- 10 - Flue exhaust temperature safety fuse
- 12 - Pre-mixed burner
- 13 - Ignition electrodes
- 14 - Spark generator
- 15 - Water inlet temperature sensor
- 16 - Fan
- 17 - Flue gas non-return valve
- 20 - Gas valve
- 22 - Detection electrode
- 23 - Inlet and outlet manifold
- 24 - CRV Heat exchanger
- 25 - Water outlet
- 26 - Water inlet
- 27 - Gas inlet
- 28 - Pressure switch against discharge clogging
- 29 - Condensate level sensor
- 30 - Condensate drain
- 31 - Condensate drain siphon
- 33 - Manifold outlet temperature sensor
- 36 - Condensate neutraliser
- 47 - Water flow rate measuring device
- 48 - Motorised 2-way valve (on request)
- 50 - Drain cocks

Figure 4-3 - 210T model functional hydraulic diagram

4 - OPERATION

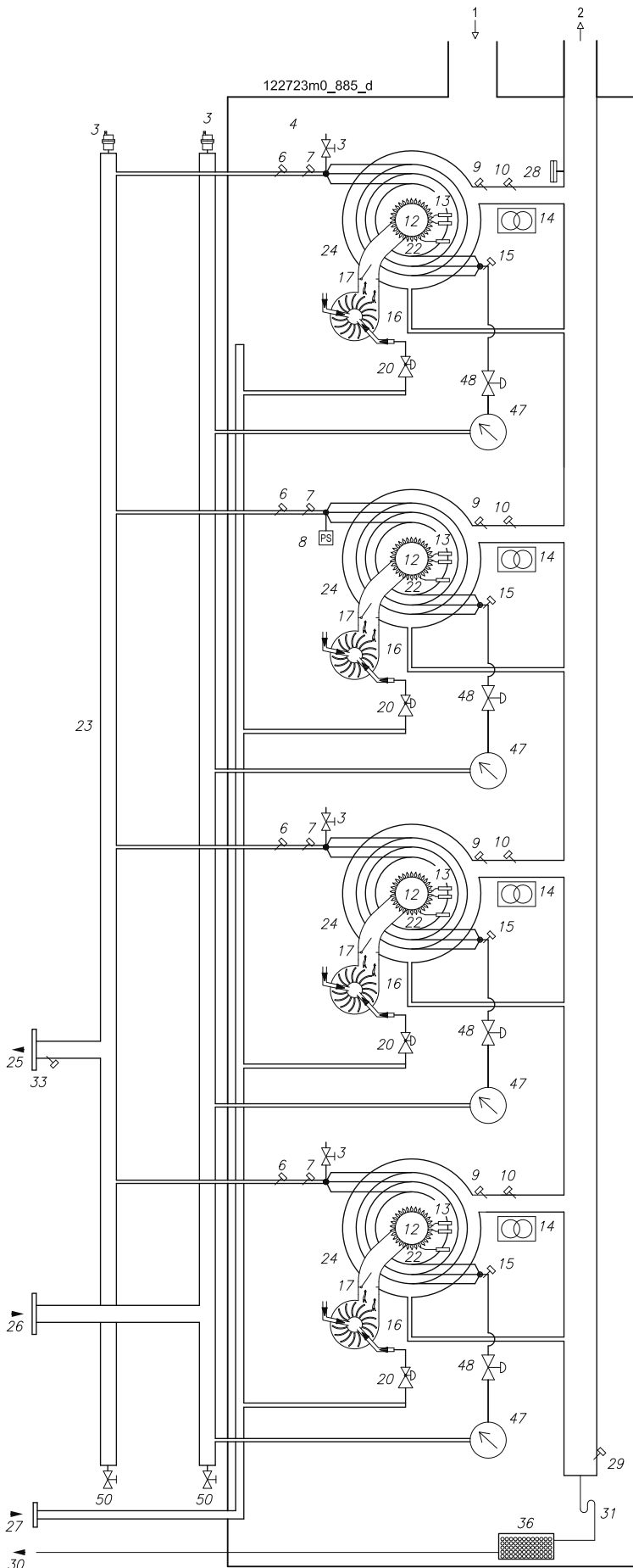

Figure 4-4 key:

- 1 - Air intake
- 2 - Flue exhaust
- 3 - Air bleed valve
- 4 - Sealed chamber
- 6 - Water outlet temperature safety thermostat
- 7 - Water outlet temperature sensor
- 8 - Water pressure measuring device
- 9 - Flue exhaust temperature sensor
- 10 - Flue exhaust temperature safety fuse
- 12 - Pre-mixed burner
- 13 - Ignition electrodes
- 14 - Spark generator
- 15 - Water inlet temperature sensor
- 16 - Fan
- 17 - Flue gas non-return valve
- 20 - Gas valve
- 22 - Detection electrode
- 23 - Inlet and outlet manifold
- 24 - CRV Heat exchanger
- 25 - Water outlet
- 26 - Water inlet
- 27 - Gas inlet
- 28 - Pressure switch against discharge clogging
- 29 - Condensate level sensor
- 30 - Condensate drain
- 31 - Condensate drain siphon
- 33 - Manifold outlet temperature sensor
- 36 - Condensate neutraliser
- 47 - Water flow rate measuring device
- 48 - Motorised 2-way valve (on request)
- 50 - Drain cocks

Figure 4-4 - 280T model functional hydraulic diagram

4 - OPERATION

4.1 - Operation and intended use

4.1.1 - Boiler operation and intended use

This is a gas condensing appliance intended to generate centralised heating. It can also be used for domestic hot water production for civil use, but it must be appropriately connected to a storage tank (see fig. 10-2). Any other use is prohibited.

Maximum domestic hot water service output heat is always guaranteed as the appliance give priority to said service.

Follow the procedure described in section 16.6 to adjust the domestic hot water temperature.

The heating system can be created with heat elements that work at a temperature range from 30°C to 80°C.

The boiler can be connected to a room thermostat, an external temperature sensor or a 0-10Vdc analogue input.

This boiler must be connected to a heating and domestic hot water production system with required output heat that is compatible with the features of the appliance itself.

4.1.2 - Water heater operation and intended use

This is a gas condensing appliance that must be connected to a civil use domestic hot water production storage tank (see fig. 11-1).

Any other use is prohibited.

4.1.3 - Wide range of modulation and maximum performance

The appliance management program, depending on the load of the heating system, provides for the gradual ignition of each single heating element at minimum output (see figure 4-5). After which, if the load of the heating system increases, all the heating elements progressively increase output. This achieves modulated output from a minimum of 14kW to a maximum corresponding to the rating of the appliance (figure 4-5 shows a 280T module with 4 heating elements), with maximum efficiency consequently maintained for the entire modulation range.

When the boiler is connected to an external temperature sensor, optimum efficiency can be achieved through direct compensation of flow temperature (see section 16.9).

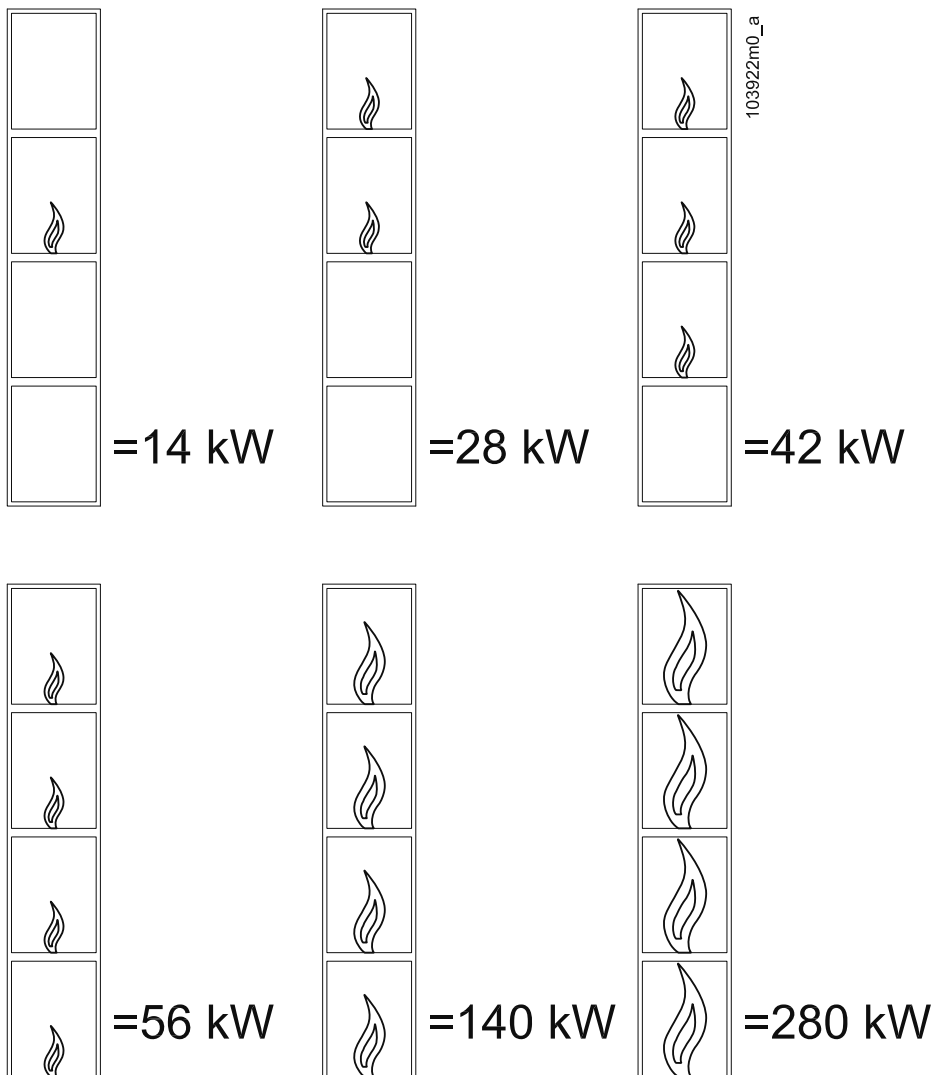

Figure 4-5 - 280T model appliance modulation

4 - OPERATION

4.1.4 - Main circuit pump

The appliance is specifically built without an integral circulation pump to give system designers the ability to select the pump most suitable for the installation. The use of modulating pumps is acceptable provided the minimum flow rates given in section 18 are achieved. The main circuit pump is item "36" in figures 10-1 and 10-2. To choose this pump, the designer must check the pressure loss information described in section 10.10 as well as the flow characteristics of the system.

4.1.5 - Heating circuit pump

The heating circuit pump, part "19" in figures 10-1 and 10-2, is not supplied with the appliance and should be selected to ensure the correct flow can be achieved and the pressure loss of the system pipework can be overcome.

4.1.6 - Domestic hot water circuit pump

The domestic hot water circuit pump, part "28" in figure 10-2 and part "36" in figure 11-1, is not supplied with the appliance and should be selected to ensure the correct flow can be achieved and the pressure loss of the system pipework can be overcome.

4.1.7 - Hydraulic separator

If the system requires a higher water flow rate than is delivered by the main circuit pump (for example a system containing multiple boilers), a hydraulic separator must be put between the boiler(s) and the system (see figures 10-1 and 10-2, part "20").

4.1.8 - Boiler domestic hot water production

An indirect water heater must be connected for domestic hot water production as shown in figure 10-2.

The domestic hot water temperature is adjusted following the procedure detailed in section 16.6.

4.1.9 - System types

The following types of systems can be created with this appliance:

- Only centralised heating system (see figure 10-1)
- Only domestic hot water production system (see figure 11-1)
- Centralised heating and domestic hot water production system (see figure 10-2).

4.2 - Precautions when installing

For proper appliance operation:

- ☞ The boiler/water heater must be connected to a heating system or to a domestic hot water distribution system, compatible with the features, performance and output of the appliance itself.
- ☞ The minimum distances shown in figures 7-1 and 7-2 must be maintained for installation and future maintenance.

4.3 - Anti-legionella

The boiler (when connected to a storage tank) and the water heater appliances have no anti-legionella protection:

It is the installer and end-user's responsibility to maintain the storage tank at a temperature no lower than 60°C or to adopt equivalent disinfection procedures.

5 - INSTALLATION - Installation site

5.1 - Choosing the installation site

 **ATTENTION !!!** Do not store any flammable material in the immediate vicinity of the appliance.

 **ATTENTION !!!** Do not install the appliance on a combustible surface.

 **ATTENTION !!!** The appliance must be installed in a room in which it can be supplied with air for ventilation and combustion, whether that air is taken from the outside (sealed combustion) or the inside (combustion in ventilated chamber).

 **ATTENTION !!!** Insufficient appliance ventilation can cause high air temperatures.

 **ATTENTION !!!** Make sure the inlet and extract openings are appropriately sized and that there are no obstructions such as flyscreens or guazes. If the problem is not resolved, do not start the appliance. Insufficient supply of combustion air can lead to incomplete combustion and cause serious harm to people or death.

 **ATTENTION !!!** Liquefied Petroleum Gas - Installation requires special attention: LPG appliances shall not be installed below ground level, e.g. in cellars or basements. This does not preclude the installation of such appliances into rooms which are low level with respect to one side of the building but open to ground level on the opposite side. In all cases, adequate low-level ventilation to the outside is essential. Failure to respect this precaution could cause explosions and serious harm to people, death or severe property damage.

 **ATTENTION !!!** This appliance will generate noise during operation. The installation location should be selected to ensure that any noise is not a nuisance to building occupants or appropriate noise damping measures should be used.

 **ATTENTION !!!** Do not allow too much dust to accumulate on the appliance.

 **ATTENTION !!!** The appliance must only be installed on solid flooring that supports the weight and is level.

 Before installing, the system should be cleaned and flushed in accordance with BSRIA Guide BG29/2012: Pre-commissioning Cleaning of Pipework Systems. Failure to correctly clean the system may lead to incorrect operation and non-warrantable failures.

 This appliance not designed for external installation. The installation location chosen should protect the appliance from extreme temperatures (below 0°C and above 50°C) and from direct sunlight and water ingress.

 This appliance must be installed in such a location that any water leaks coming from it, from the connections between the pipes or from potential safety valve drainage cannot cause damage to materials underneath it.

Establish the appropriate room and position for installation, keeping the following factors in mind:

- flue exhaust/air intake duct connection;
- gas supply connection;
- water supply connection;
- centralised heating system connection;
- domestic hot water system connection (if present);
- electrical connection;
- connection of the condensate drain generated by the boiler;
- room thermostat electrical connection;
- safety valve discharge connection;
- any external temperature sensor connection;
- room ventilation.

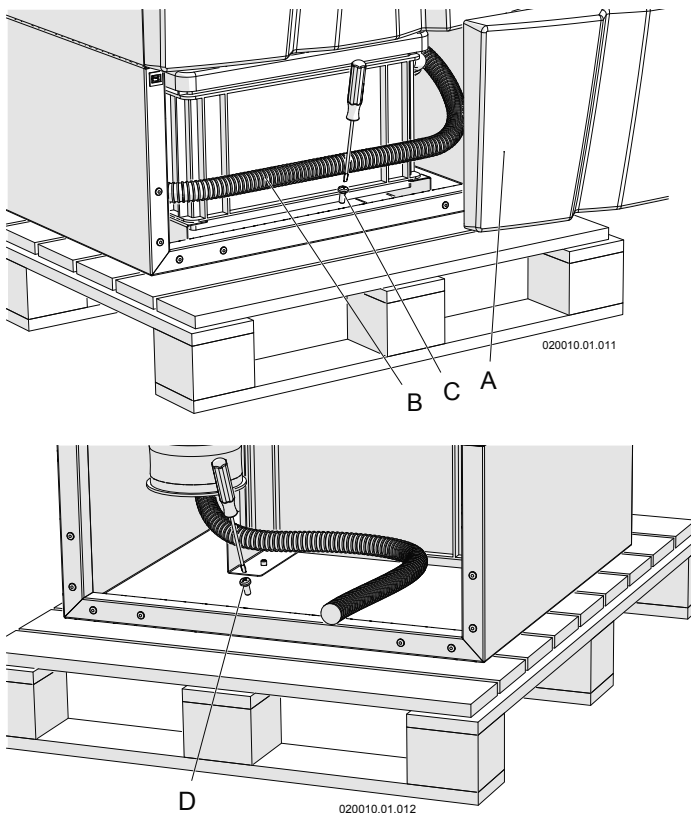
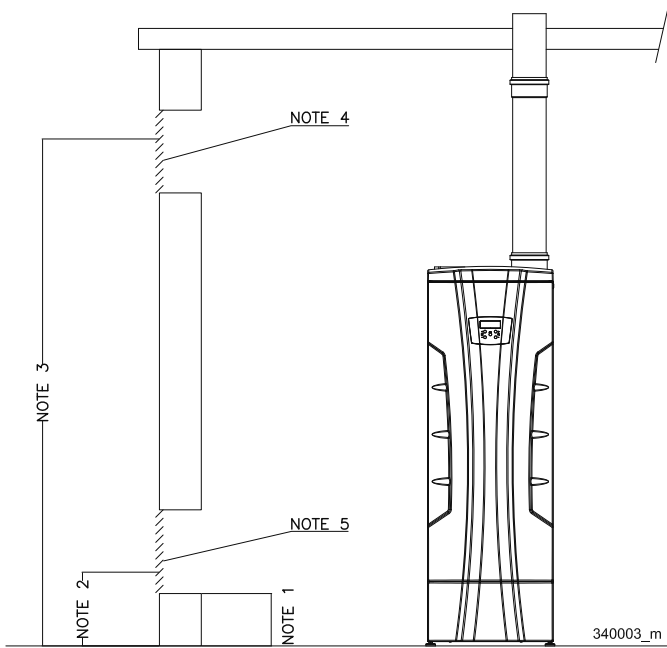

Figure 5-1 - Disassembling transport pallet screws

5 - INSTALLATION - Installation site



NOTE 1: For LPG installations, ventilation must be within 250 mm from floor level.

NOTE 2: At least 20% of low-level ventilation allowance to be below 1000 mm from floor level.

NOTE 3: At least 20% of high-level ventilation allowance to be above 85% of maximum room height.

NOTE 4: Operation <50% of time = $2\text{ cm}^2/\text{kW}$ (total net input);
 Operation 50 - 75% of time = $3\text{ cm}^2/\text{kW}$ (total net input);
 Operation >75% of time = $4\text{ cm}^2/\text{kW}$ (total net input).

NOTE 5: Operation <50% of time = $4\text{ cm}^2/\text{kW}$ (total net input);
 Operation 50 - 75% of time = $5\text{ cm}^2/\text{kW}$ (total net input);
 Operation >75% of time = $6\text{ cm}^2/\text{kW}$ (total net input).

Figure 5-2 Example of ventilation

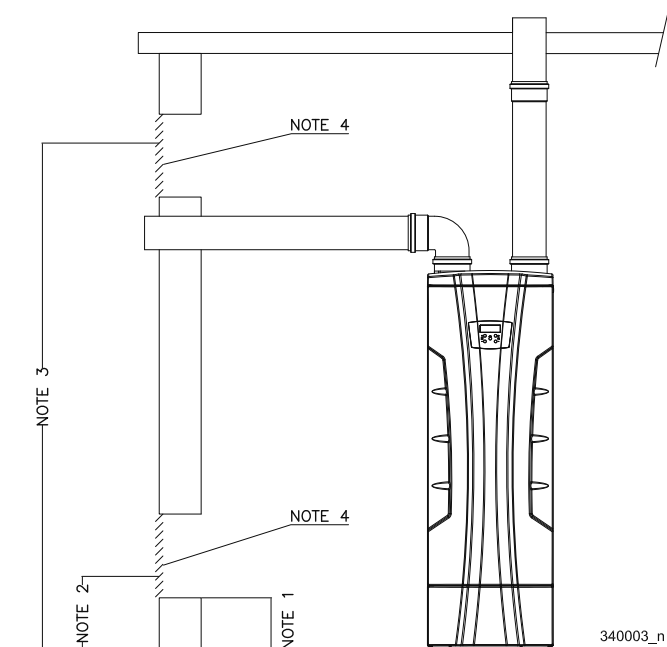

NOTE 1: For LPG installations, ventilation must be within 250 mm from floor level.

NOTE 2: At least 20% of low-level ventilation allowance to be below 1000 mm from floor level.

NOTE 3: At least 20% of high-level ventilation allowance to be above 85% of maximum room height.

NOTE 4: Operation <50% of time = $2\text{ cm}^2/\text{kW}$ (total net input);
 Operation 50 - 75% of time = $3\text{ cm}^2/\text{kW}$ (total net input);
 Operation >75% of time = $4\text{ cm}^2/\text{kW}$ (total net input).

Figure 5-3 Example of ventilation

5.1.1 Requirements for proper ventilation

The plant room **MUST** have a properly sized ventilation openings. To ensure proper ventilation for combustion, high and low level ventilation shall be installed. Where the appliance is installed in an open-flue (B23) configuration, ventilation shall be directly to outside and the free area of openings shall be as detailed in figure 5-2.

Room sealed appliances (type C) should be provided with ventilation with free area as detailed in figure 5-2.

Low level ventilation shall be provided as low as practicable and be within 1 m of the plant room floor for natural gas installations and within 250 mm of the floor for LPG installations.

Further guidance on ventilation provision including the use of mechanical ventilation systems can be found within IGEM/UP/10 Edition 4.



ATTENTION !!! The ventilation system shall be designed to ensure the plant room is not under suction therefore, consideration should be given to the presence of any discharge fans, ceiling fans, dryers, compressors, air heating units, etc. that may take air away from the appliance.



ATTENTION !!! Extractors or similar devices to discharge air from the plant room can reverse the flow through the flue system and cause very dangerous conditions that must be corrected immediately.

5.1.2 - Preventing combustion air contamination

Do not position air intakes in locations where combustion air can be contaminated.



ATTENTION !!! Contaminated combustion air can damage the appliance.

Make sure the combustion air does not contain any of the following contaminating agents.

Products that can contaminate combustion air:

- Permanent wave solutions;
- Chlorinated waxes/cleaning products;
- Chlorine-based pool chemical products;
- Calcium chloride used for defrosting;
- Sodium chloride used to soften water;
- Coolant leaks;
- Solutions to remove paint or varnish;
- Hydrochloric acid/muratic acid;
- Cements and adhesives;
- Antistatic softeners used in dryers;
- Chloro-type bleaches, detergents and cleaning solvents found in laundry rooms for home use;
- Adhesives used to secure construction products and other similar products;

6 - INSTALLATION - Setup

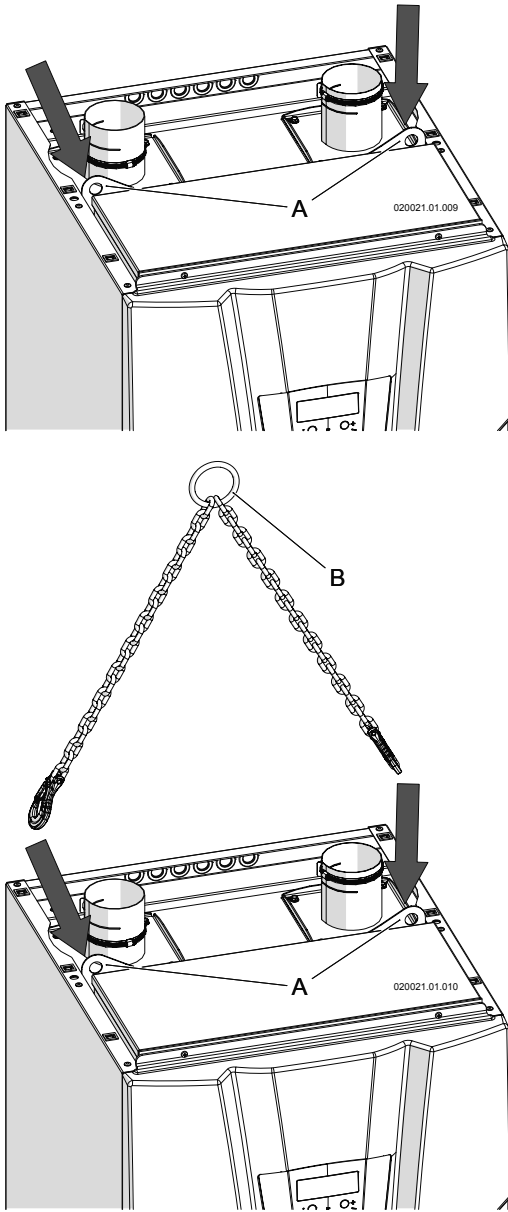

Figure 6-1 - Lifting system

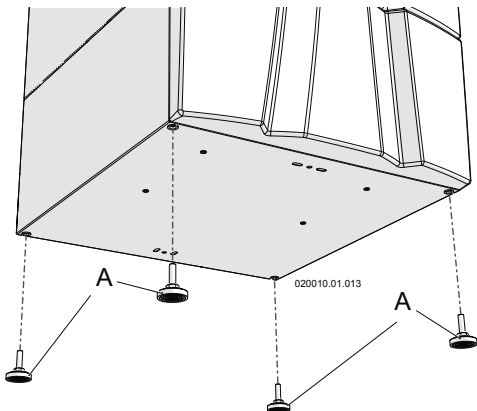

Figure 6-2 - Levelling feet

6.1 - Setup

To correctly and easily install the appliance, the following steps must be followed. Failure to follow these instructions may lead to non-warrantable damage to the appliance or severe personal injury.

6.1.1 - Moving the appliance



ATTENTION !!! Use appropriate lifting apparatus for the type of appliance and location to move it. Use of incorrect apparatus may lead to non-warrantable damage to the appliance or severe personal injury.

Position the appliance in the area chosen for installation, secured to the pallet on which it is supplied, making sure to keep it upright without making any sudden movements that could cause it to overturn. To free the appliance from the pallet, unscrew the front (part "C" in figure 5-1) and rear (part "D" in figure 5-1) fixing screws.

6.1.2 - Opening the package

The appliance is supplied in cardboard packaging secured to a pallet for transport. Be careful when opening, lift the cardboard box upwards after having detached it from the pallet.

6.1.3 - Lifting the appliance

There is a bracket (part "A" in figure 6-1) to facilitate installation that allows the appliance to be lifted.

- ☞ remove the upper covering as per section 17.2;
- ☞ hook the lifting cables, "B" in figure 6-1, to the bracket, "A" in figure 6-1, and lift the heating module;



ATTENTION !!! The lifting cables and system must be suitable and have a maximum rating that exceeds the weight of the appliance, which is detailed in section 18.

- ☞ install the adjustable feet "A" to level the appliance as per figure 6-2.

Once the appliance has been positioned properly, the lifting cables (part "B" in figure 6-1) must be removed before applying the upper covering.

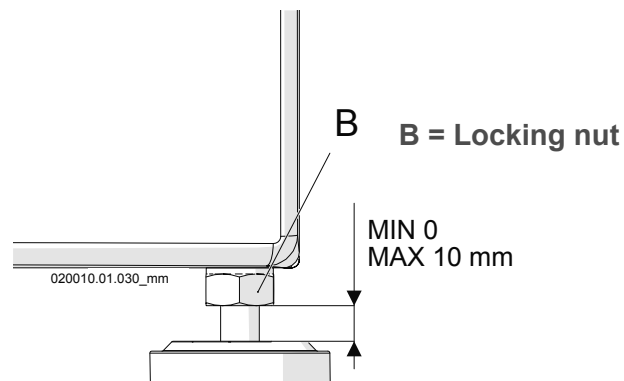

7 - INSTALLATION - Minimum distances to respect

7.1 - Dimensions and minimum distances to respect

Free space must be left around the appliance both for installation and maintenance, as illustrated in figures 7-1 and 7-2. Figures 8-1, 8-2, 9-1 and 9-2 show the appliance connection dimensions and centre distances.

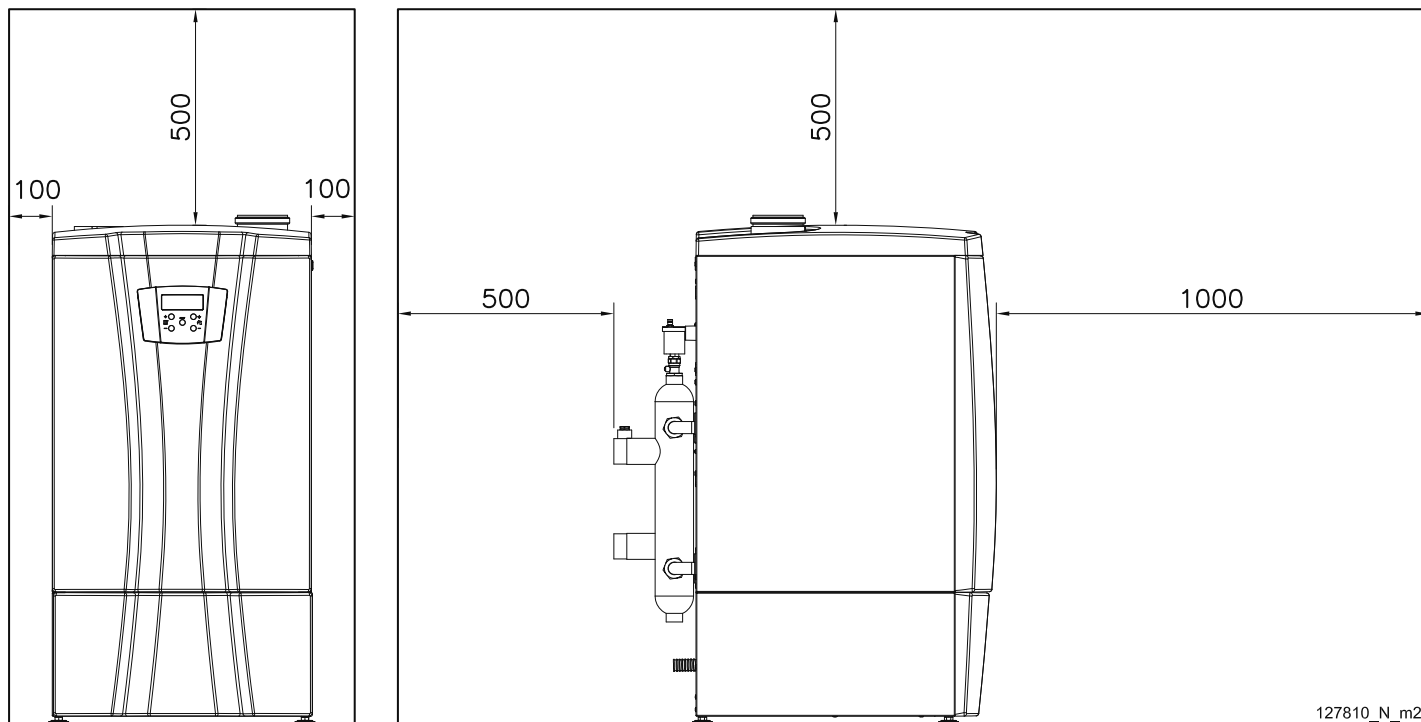

Figure 7-1 - Minimum distances to respect for 70T and 140T models

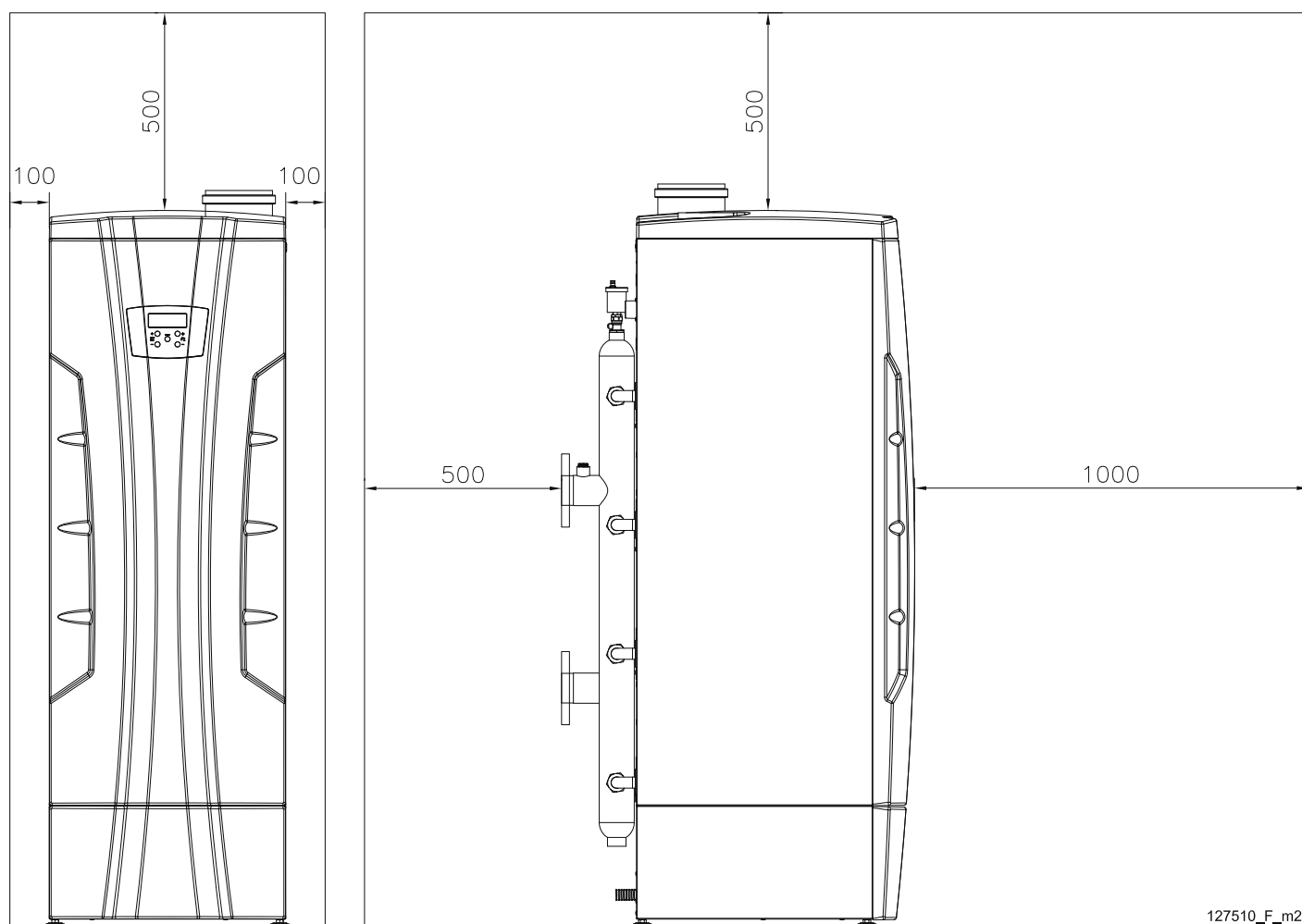

Figure 7-2 - Minimum distances to respect for 210T and 280T models

8 - INSTALLATION - Dimensions and centre distances - Boiler

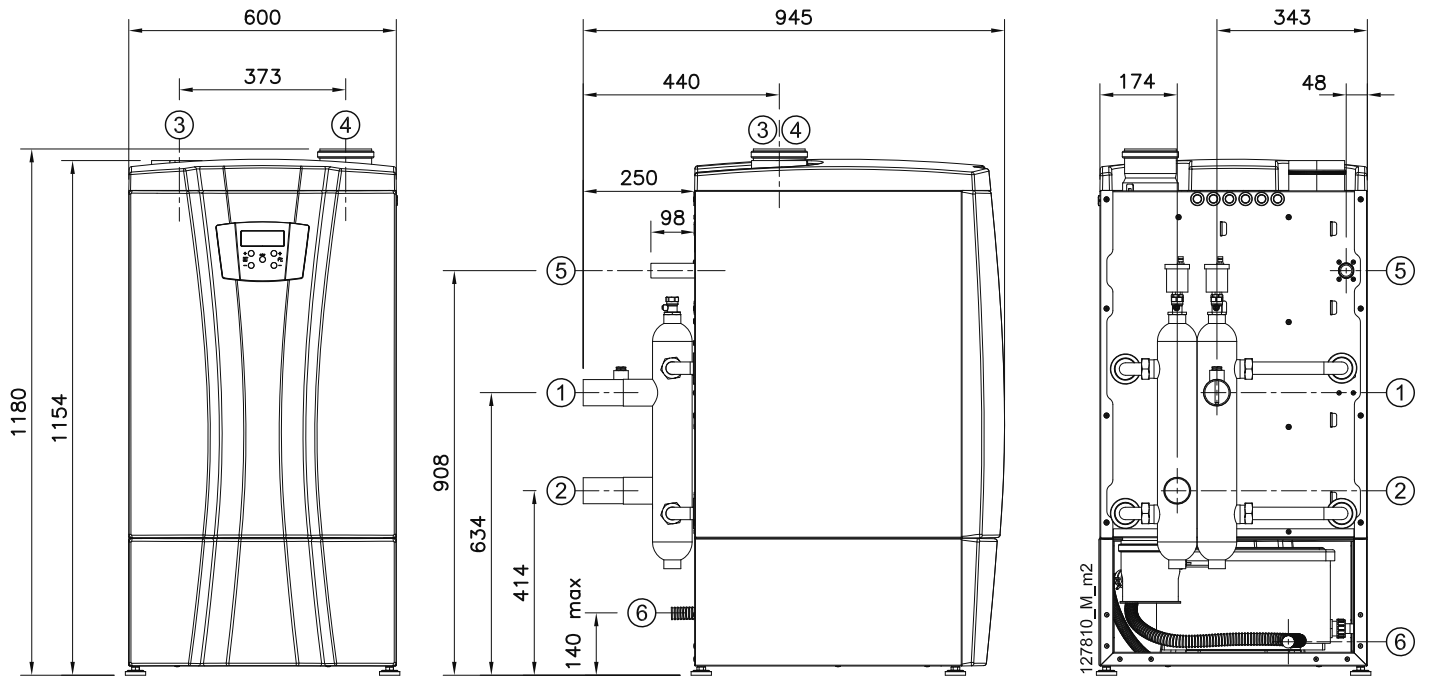

Figure 8-1 - Fitting dimensions and centre distances for 70T and 140T models (References in figure 8-3)

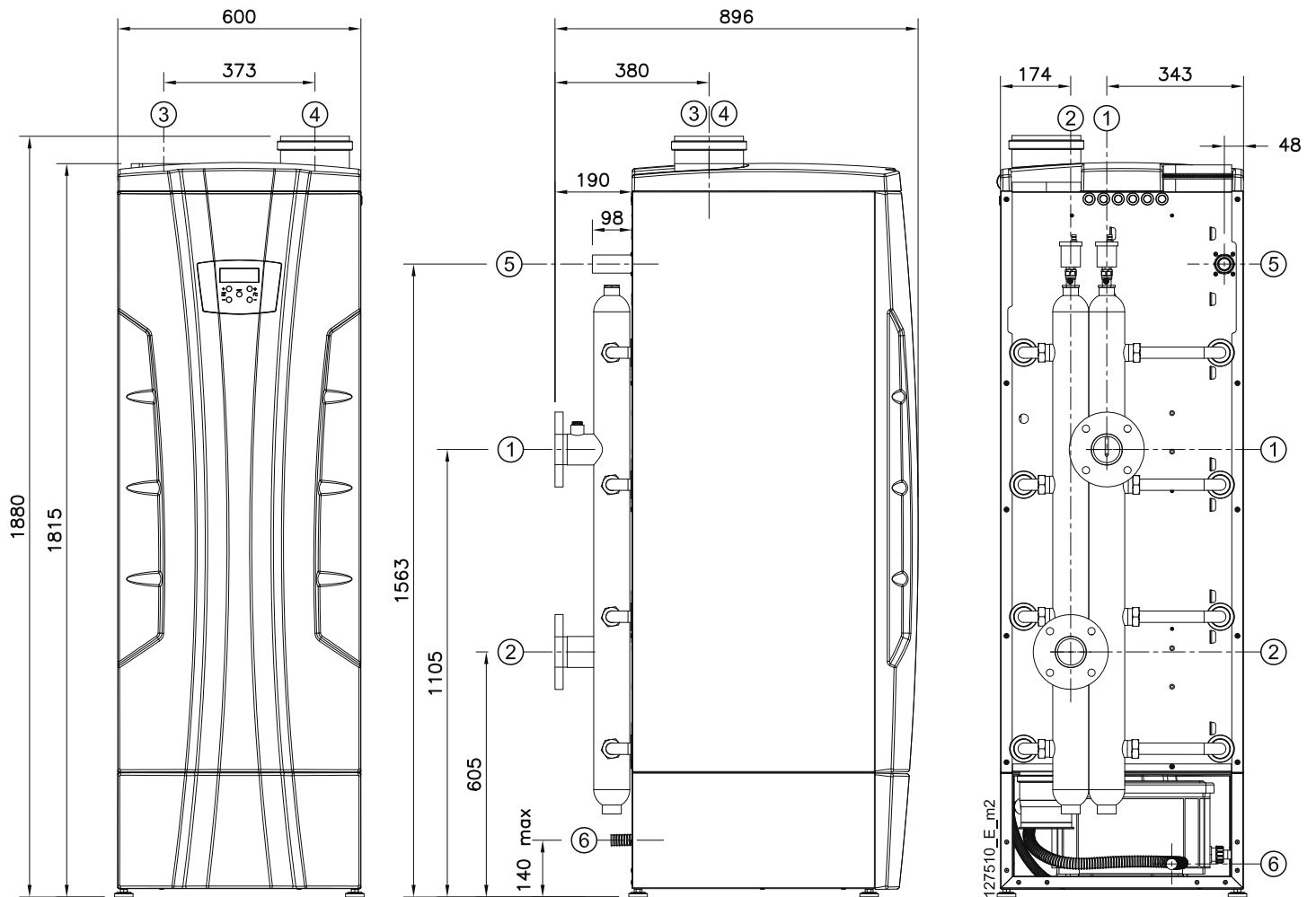

Figure 8-2 - Fitting dimensions and centre distances for 210T and 280T models (References in figure 8-3)

8 - INSTALLATION - Dimensions and centre distances - Boiler

MODEL	① SUPPLY	② RETURN	③ AIR INTAKE	④ FLUE EXHAUST	⑤ GAS	⑥ CONDENSATE DRAIN
70T	1"1/2	1"1/2	80 mm	80 mm	1"	28mm
140T	1"1/2 *	1"1/2 *	110 mm	110 mm	1"	28mm
210T	DN65 PN16 *	DN65 PN16 *	160 mm	160 mm	1"1/4	28mm
280T	DN65 PN16 *	DN65 PN16 *	160 mm	160 mm	1"1/4	28mm

* Fittings and flanges are not factory assembled

Figure 8-3 - Figure 8-1 and 8-2 connection diameter table

9 - INSTALLATION - Dimensions and centre distances - Water heater

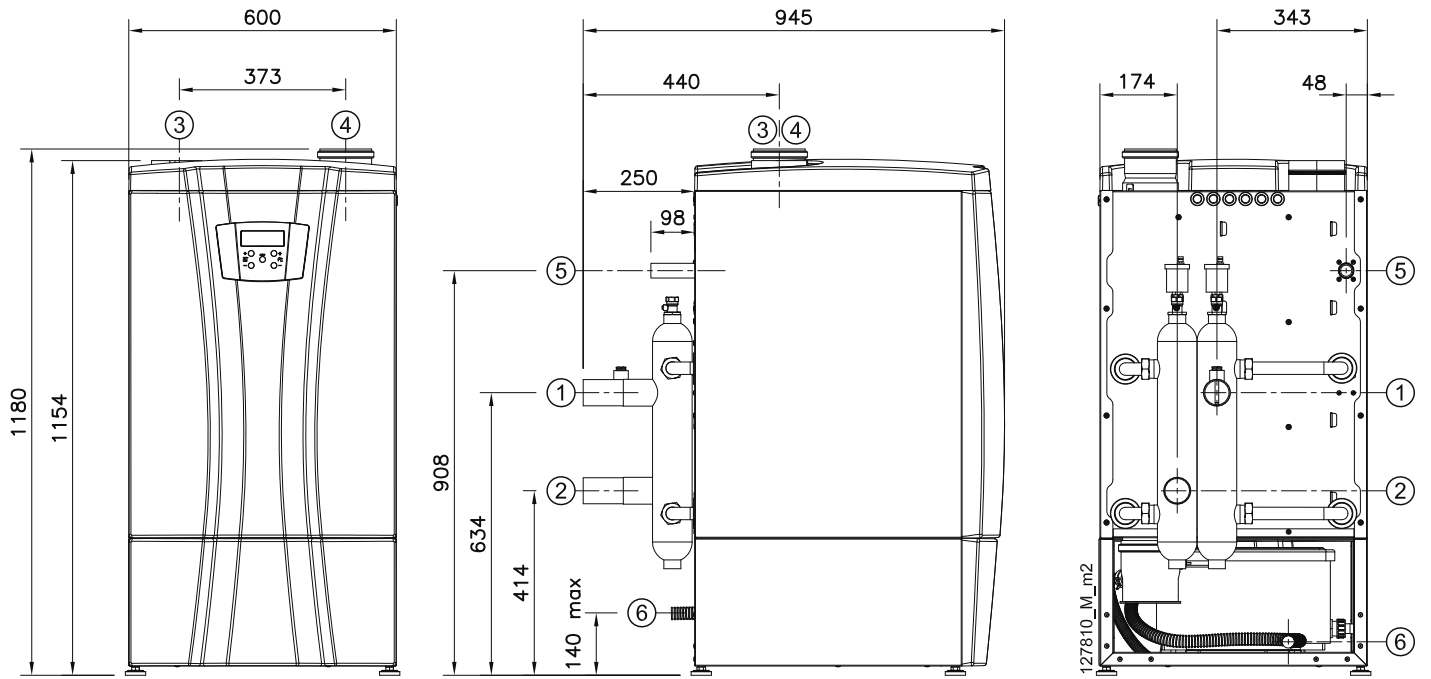

Figure 9-1 - Fitting dimensions and centre distances for 70T and 140T models (References in figure 9-3)

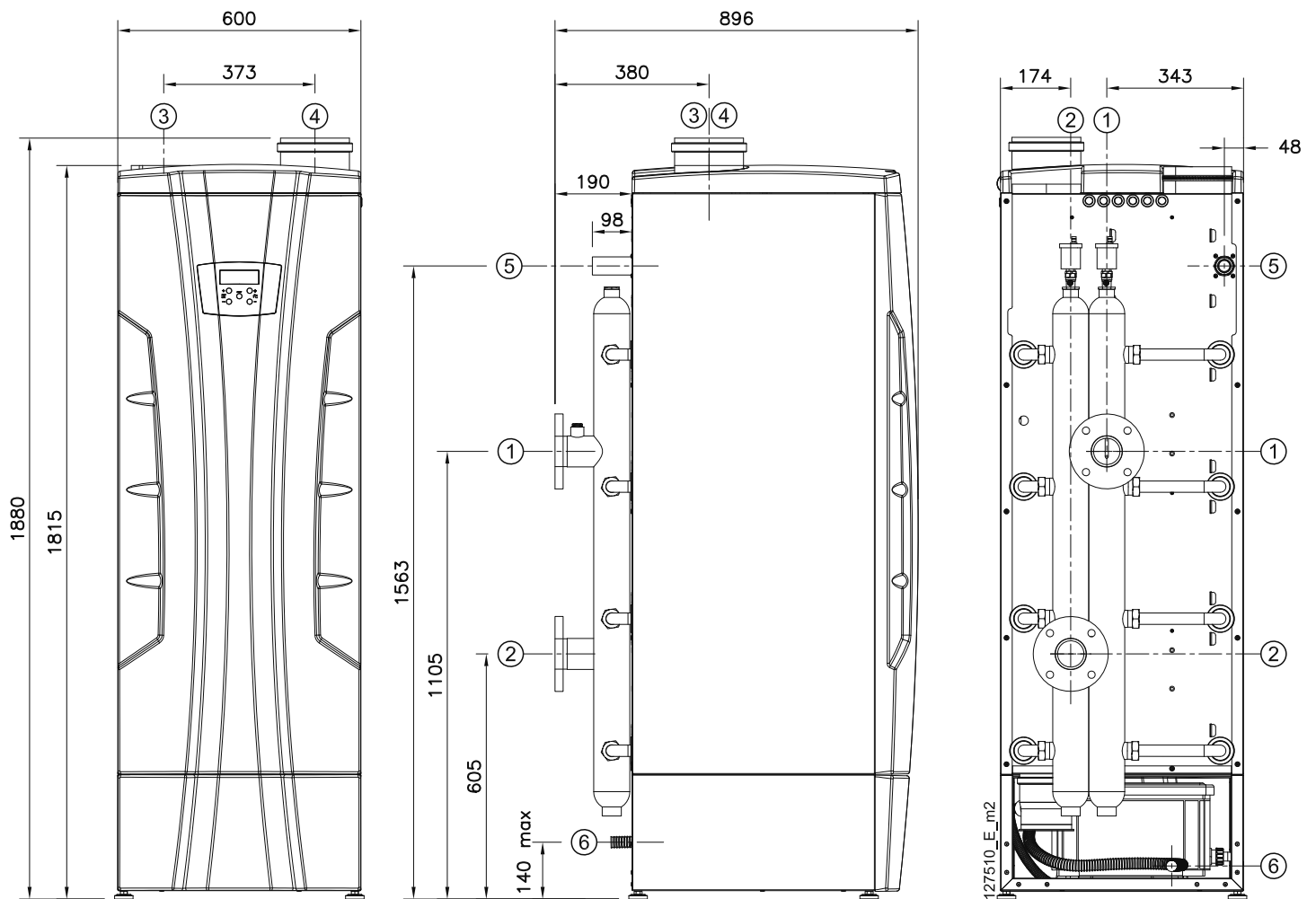

Figure 9-2 - Fitting dimensions and centre distances for 210T and 280T models (References in figure 9-3)

9 - INSTALLATION - Dimensions and centre distances - water heater

MODEL	① WATER OUTLET	② WATER INLET	③ AIR INTAKE	④ FLUE EXHAUST	⑤ GAS	⑥ CONDENSATE DRAIN
70T	1"1/2	1"1/2	80 mm	80 mm	1"	28mm
140T	1"1/2 *	1"1/2 *	110 mm	110 mm	1"	28mm
210T	DN65 PN16 *	DN65 PN16 *	160 mm	160 mm	1"1/4	28mm
280T	DN65 PN16 *	DN65 PN16 *	160 mm	160 mm	1"1/4	28mm

* Fittings and flanges are not factory assembled

Figure 9-3 - Figure 9-1 and 9-2 connection diameter table

10 - INSTALLATION - Hydraulic connections - boiler

10.1 - Boiler gas and hydraulic connections



ATTENTION !!! Before installing, the system should be cleaned and flushed in accordance with BSRIA Guide BG29/2012: Pre-commissioning Cleaning of Pipework Systems. Failure to correctly clean the system may lead to incorrect operation and non-warrantable failures.

To identify the position of the fittings, see figures 8-1 and 8-2.

Gas connection

The gas connection must be made at the correct fitting with a rigid metal pipe. Any gas meter should be sized for simultaneous use of all the gas appliances connected to it. Connect the gas to the appliance according to the standards in force. The diameter of the gas connection of the appliance does not determine the diameter of the gas supply pipework. Gas supply pipework should be selected and installed in accordance with IGEM/UP/2 Edition 3.



ATTENTION !!! In order to be able to shut off the gas supply, an approved appliance isolating valve (not supplied) should be installed in the gas supply pipework next to the appliance.



ATTENTION !!! The appliance must only be connected to a gas supply for which it has been manufactured or converted. Details on gas conversion can be found in section 15.4 or 15.5. The supply of any other type of gas to the appliance is prohibited.

10.2 - Boiler safety valve (installer's responsibility)

The appliance is supplied without an overpressure safety valve. The system designer or the installer must select an appropriate valve for the maximum system pressure and output rating (maximum working pressures and output of the appliance as detailed in section 18). The discharge pipe from the safety valve shall fall continuously from the point of connection to its termination so that the discharge pipe shall be self-draining and shall terminate in a visible position and where discharge cannot result in hazard to any person or to the appliance.



ATTENTION !!! If the safety valve is not directed, it could harm persons, animals or objects should it operate.

10.3 - Examples of boiler installations

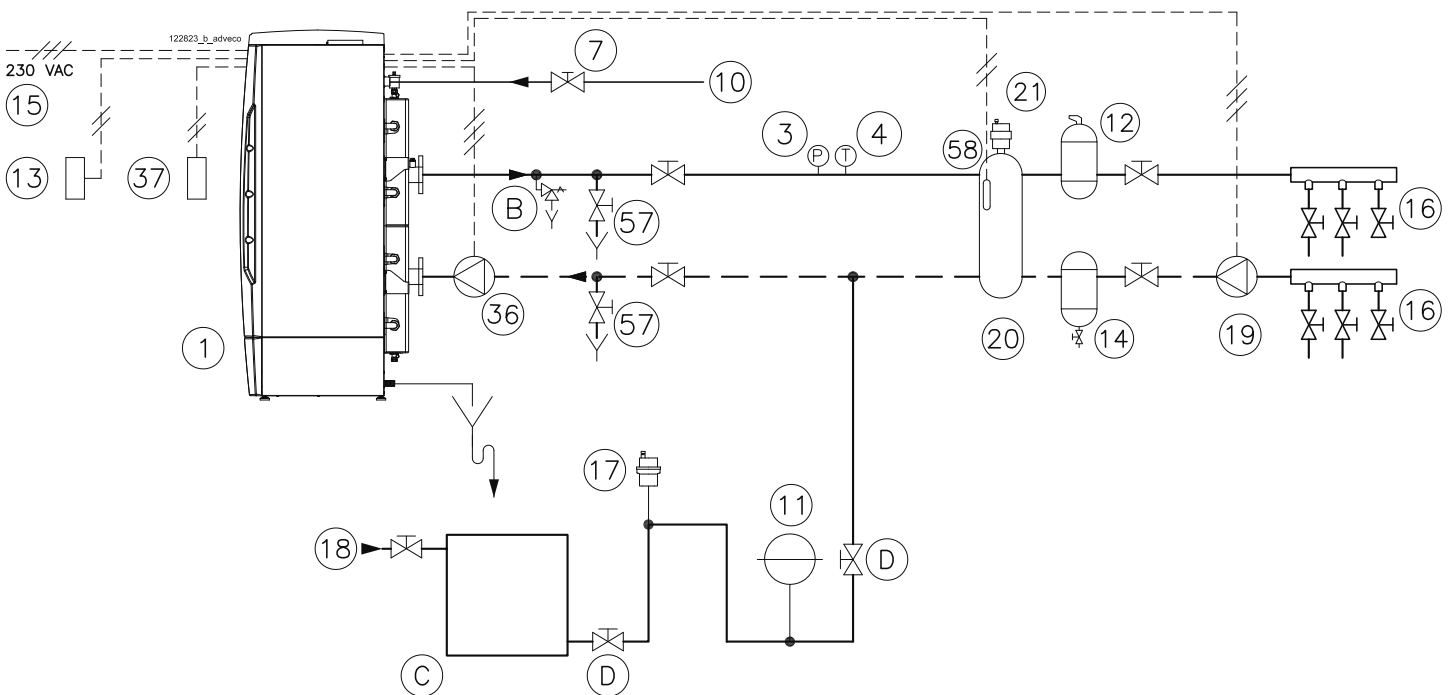

Figure 10-1 - Example of boiler connection diagram

Figure 10-1 KEY

1 Boiler 60T-280T model boiler

3 INAIL manometer

4 INAIL thermometer

7 Gas cock

10 Gas inlet

11 Expansion tank

12 Micro-bubble separator

13 External temperature sensor

14 Filter

15 Electrical power supply

16 Low or high temperature heating system

17 System loading unit

18 Domestic cold water

19 Heating circuit pump

20 - Hydraulic separator

21 Air bleed valve

36 Main circuit pump

37 Room thermostat or equivalent system

57 Drain cock (Mandatory in the 70 and 140 models)

58 Manifold sensor

B Expansion Relief Valve

C Pressurisation Unit

D Lock-Shield Valve

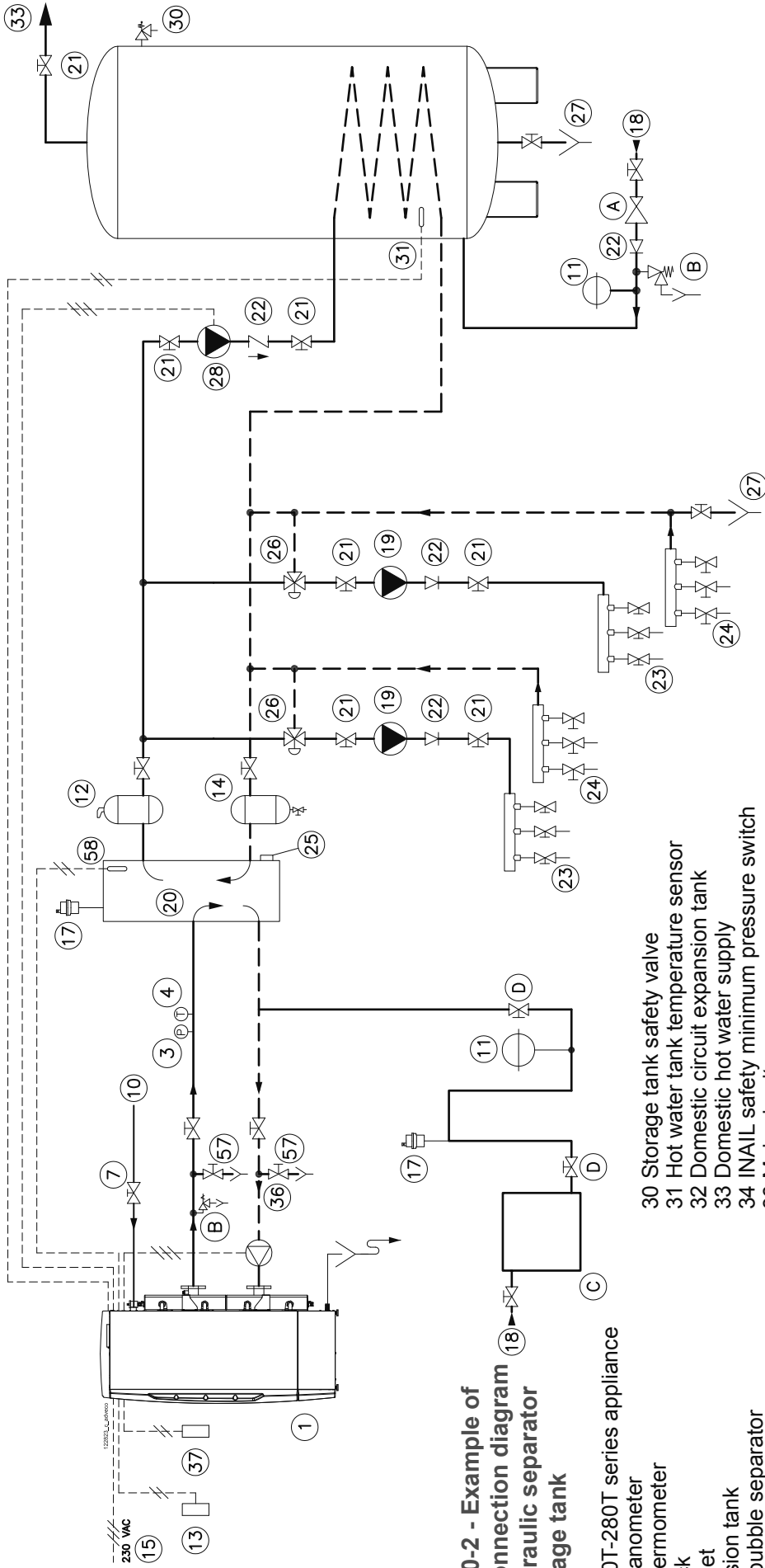

Figure 10-2 - Example of boiler connection diagram with hydraulic separator and storage tank

- 1 Boiler 60T-280T series appliance
- 3 INAIL manometer
- 4 INAIL thermometer
- 7 Gas inlet
- 10 Expansion tank
- 11 Micro-bubble separator
- 13 External temperature sensor
- 14 Filter
- 15 Electrical power supply
- 17 Air bleed valve
- 18 Domestic cold water
- 19 Heating circuit pump
- 20 - Hydraulic separator
- 21 Shut-off valve
- 22 Check valve
- 23 Heating system supply
- 24 Heating system return
- 25 Plug for sludge drain
- 26 Heating system mixing valve
- 27 System drain
- 28 Storage tank loading pump
- 29 System loading unit
- 30 Storage tank safety valve
- 31 Hot water tank temperature sensor
- 32 Domestic circuit expansion tank
- 33 Domestic hot water supply
- 34 INAIL safety minimum pressure switch
- 36 Main circuit pump
- 37 Room thermostat or equivalent system
- 56 Balancing valve (necessary if there is a motorised valve, part "17" in Figure 3-1, on the appliance and the pump, "36", is **NOT** the modulating type)
- 58 Drain cock (Mandatory in the 70 and 140 models)
- A Manifold sensor
- B Pressure Reducing Valve
- C Pressurisation Unit
- D Lock-Shield Valve

10 - INSTALLATION - Hydraulic connections - boiler

10.4 - Expansion tank connection



ATTENTION !!! The appliance does not have an integral expansion vessel. When connected to a sealed system an appropriately sized expansion vessel shall be fitted to comply with the relevant installation standards.

10.5 - Supply and return



ATTENTION !!! COSMOGAS & Adveco are not liable for any damage caused by incorrect use of additives in the heating system.



ATTENTION !!! The system downstream of the appliance must be built with materials suitable for temperatures up to 97°C and pressure up to 11 bar. The system must be equipped with appropriate protection and safety devices to ensure the maximum operating characteristics of any component in the system are not exceeded.

Before making the hydraulic connections, flush the system thoroughly to remove any debris (jointing compounds, radiator foundry sands, etc.) that could damage the appliance. The system must also be cleaned and flushed if an appliance is replaced.

You can check the positioning of the supply and return fittings in figures 8-1 and 8-2.

☞ Install a metal mesh strainer with 1 mm² openings on the return pipe in order to prevent any system residues entering the appliance.

☞ Do not use the appliance to introduce any type of additives into the system.

10.6 - Boiler water supply



ATTENTION !!! The system (and, therefore, the appliance) must be connected to the water mains through a backflow prevention device, as required by the regulations in force.

10.6.1 - Recommendations on the characteristics of the water used in the system

Filling the heating system is an extremely delicate operation that must not be underestimated, both when simply replacing the heat generator as well as for new installations. A mistaken assessment of the system water characteristics can, in certain cases, lead to damages to the system and heating module. A system is almost never perfectly sealed; at times, there can be water leaks or oxygen inlets. Both of these phenomena are harmful.

Of the parameters that can negatively impact the life of a system, the main ones are:

- The simultaneous presence of different metals (copper, brass, steel and aluminium) that, in a watery environment, lead to galvanic corrosion.

- The presence of free oxygen, due to air leaks that form near fittings or gaskets, is a typical corrosive agent, particularly active at temperatures between 50 and 70°C.

- Water loss, leading to frequent top-ups, can lead both to corrosion as well as scale build-up, depending on the type of

water available for the top-ups. In any case, the extent of the leaks (and corresponding top-ups) must be kept under control, especially when an automatic filling system is installed. In this case, installing a water meter, to monitor the amount of water that is added to the system is highly recommended.

Natural or additional impurities in the water. Many types of drinking water can contain high concentrations of chlorides and sulphates that can increase how quickly the metal surfaces corrode. Other undesirable components may have entered the system before or during installation (construction materials, metal shavings, sawdust, grease, deposits, and dirt in general). Welding residues can also cause corrosion, both in new systems as well as in the event of modifications or repairs. In old systems designed to work with radiators, featuring very large pipe diameters, the water content is considerable and favours the formation of sludge and deposits.

Sludge and scale build-up Black deposits (magnetite) indicate that corrosion is limited. However, the high specific gravity of this oxide can create clogs that are difficult to remove, especially in the hotter areas. Scale build-up is due to water hardness, that is, the presence of calcium and magnesium minerals. Calcium, in the form of carbonate, falls on the hotter areas of the system. Magnetite often contributes in intensifying the scale build-up. Iron oxide (the water has a reddish colour), instead, is a sign of oxygen corrosion.

Frequent leaks. In the event of frequent leaks, hydrogen and/or air accumulates on the high part of the exchanger and the radiators, preventing complete heat exchange. When the electrolytic corrosion process begins, the water level in the system goes down, gases accumulate in the high part of the heat exchanger and on the radiators. The presence of air is caused by the fact that the system might not be perfectly sealed. Slow system pressure loss due to a leak is often difficult to find, especially when the breach is very small (during winter, leaks on the radiator valves are often not visible as the heat generated by the radiator or the boiler dry them). However, these micro-leaks allow air to get into the system. The main points that can lead to micro-leaks are found in the joints and, in particular, on the circulator intake side (air bleed valve, seals with o-rings, loading valves). In these cases, to avoid damage, the system must be protected with an appropriate corrosion inhibitor.

10.6.2 - For the system to operate properly, you must make sure that:

- 1) the system has no leaks or, at the least, the most evident leaks have been removed;
- 2) if there is an automatic filling system, a water meter must be installed in order to accurately know the extent of any leaks;
- 3) system filling and top-ups are done with water with a hardness of 120 ppm to 200 ppm CaCO₃. The water **must** also be treated in order to keep the pH within the required threshold to prevent corrosion;
- 4) Both in new systems and for replacements, the system must be equipped with efficient devices that eliminate air and impurities: filters, micro-impurity separators and micro-air bubble separators;
- 5) Avoid draining system water during scheduled maintenance, even seemingly insignificant amounts: for example, to clean the filters, equip the system with specific shut-off valves upstream and downstream of the filter itself;
- 6) Fill the heating system and analyse the water composition. If the water shows the following values the water is acceptable:

- Hardness from 120 ppm to 200 ppm CaCO₃
- 7.5 < pH < 9.5

If the characteristics are different, an inhibitor must be used.

10 - INSTALLATION - Hydraulic connections - boiler

10.6.3 Treating water in heating systems for commercial use

Water must always be treated in heating systems for commercial use, both when replacing the generator and in the event of a new system.

The design stage, based on the characteristics of the raw water, must provide for all the treatment and chemical conditioning systems needed to obtain water with the following characteristics:

- Appearance: clear, colourless and non-foamy;
- pH: from 7.5 a 9.5;
- Hardness from 120 ppm to 200 ppm CaCO₃;
- Conditioners: present within the concentrations prescribed by the *supplier*.

If the water characteristics are unknown, there is a very high probability of encountering the following typical setbacks:

a. SCALE BUILD-UP

In a system containing 1000 litres of water at 300 ppm, the CaCO₃ content is equal to 300 g. If not appropriately treated, it will deposit on the surface of the heat exchanger as that is the hottest point of the system, creating concentrated increases in temperature and leading to the heat exchanger breaking.

b. CORROSION

Corrosion is usually facilitated by the presence of oxygen, by contact between different metals or by the presence of chlorides.

c. DEPOSITS

SLUDGE, PROCESSING RESIDUES are organic and inorganic insoluble substances.

10.7 - Draining the boiler heating circuit

In order to avoid constant water top-ups and subsequent oxygen and scale, it is advisable to limit draining the heating circuit as much as possible.

10.8 - Boiler low temperature (or floor) systems



ATTENTION !!! If the boiler is installed in an underfloor heating system built with plastic piping, all precautions against corrosion due to water oxygenation must be taken:

make sure the system is built with plastic piping with an oxygen permeability no greater than 0.1 g/m³ at 40°C. Should the pipe not meet these features, the boiler heat exchanger circuit must be separated using a plate heat exchanger that can resist the corrosion caused by the oxygen dissolved in the water.

10.9 - Manifold sensor

The manifold sensor (part 26 in figure 3-5 and 3-7) is factory installed on the boiler manifold. However, that position may not be correct in some systems where there is a hydraulic separator or plate exchanger (see figures 10-1 and 10-2). It is advisable to move the sensor from the boiler manifold to the hydraulic separator as shown in figures 10-1 and 10-2, part "58".



ATTENTION !!! For the system to work properly, the manifold sensor must be positioned in a point of the hydraulic separator/plate exchanger, able to detect the correct supply temperature and able to be influenced by the secondary circuit water flow temperature

10.10 - Characteristic curve of the boiler head loss

The boiler is not equipped with a circulation pump. To select the pump, the designer must consider the hydraulic resistances of the system and the hydraulic resistances of the boiler itself. Figure 10-5 shows the hydraulic resistances of the boilers at various flow rates.

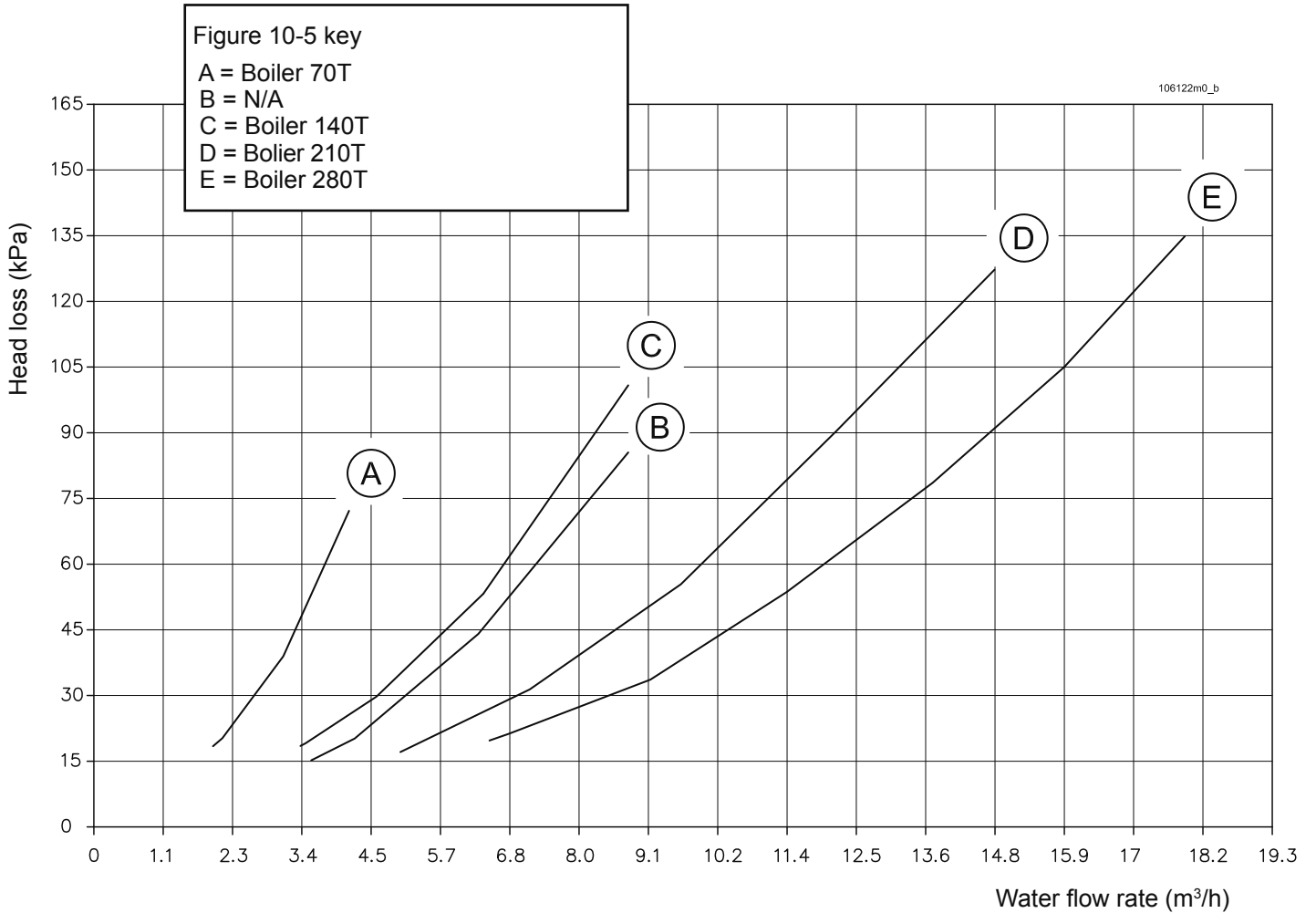

Figure 10-5 - Boiler "60T-280T" model hydraulic resistances

11 - INSTALLATION - Hydraulic connections - water heater

11.1 - Water heater gas and hydraulic connections

ATTENTION !!! Use appropriate lifting apparatus for the type of appliance and location to move it. Use of incorrect apparatus may lead to non-warrantable damage to the appliance or severe personal injury.

To identify the position of the fittings, see figures 9-1 and 9-2.

Gas connection

The gas connection must be made at the correct fitting with a rigid metal pipe. Any gas meter should be sized for simultaneous use of all the gas appliances connected to it. Connect the gas to the appliance according to the standards in force. The diameter of the gas connection of the appliance does not determine the diameter of the gas supply pipework. Gas supply pipework should be selected and installed in accordance with IGEM/UP/2 Edition 3.

ATTENTION !!! In order to be able to shut off the gas supply, an approved appliance isolating valve (not supplied) should be installed in the gas supply pipework next to the appliance.

ATTENTION !!! The appliance must only be connected to a gas supply for which it has been manufactured or converted. Details on gas conversion can be found in section 15.4 or 15.5. The supply of any other type of gas to the appliance is prohibited.

11.2 - Water heater safety valve (installer's responsibility)

The appliance is supplied without an overpressure safety valve. The system designer or installer must select an appropriate valve for the maximum system pressure (maximum working pressures and output of the appliance care detailed in section 18). The discharge pipe from the safety valve shall fall continuously from the point of connection to its termination so that the discharge pipe shall be self-draining and shall terminate in a visible position and where discharge cannot result in hazard to any person or to the appliance.

ATTENTION !!! If the safety valve is not directed, it could harm persons, animals or objects should it operate.

11.3 - Examples of water heater installations

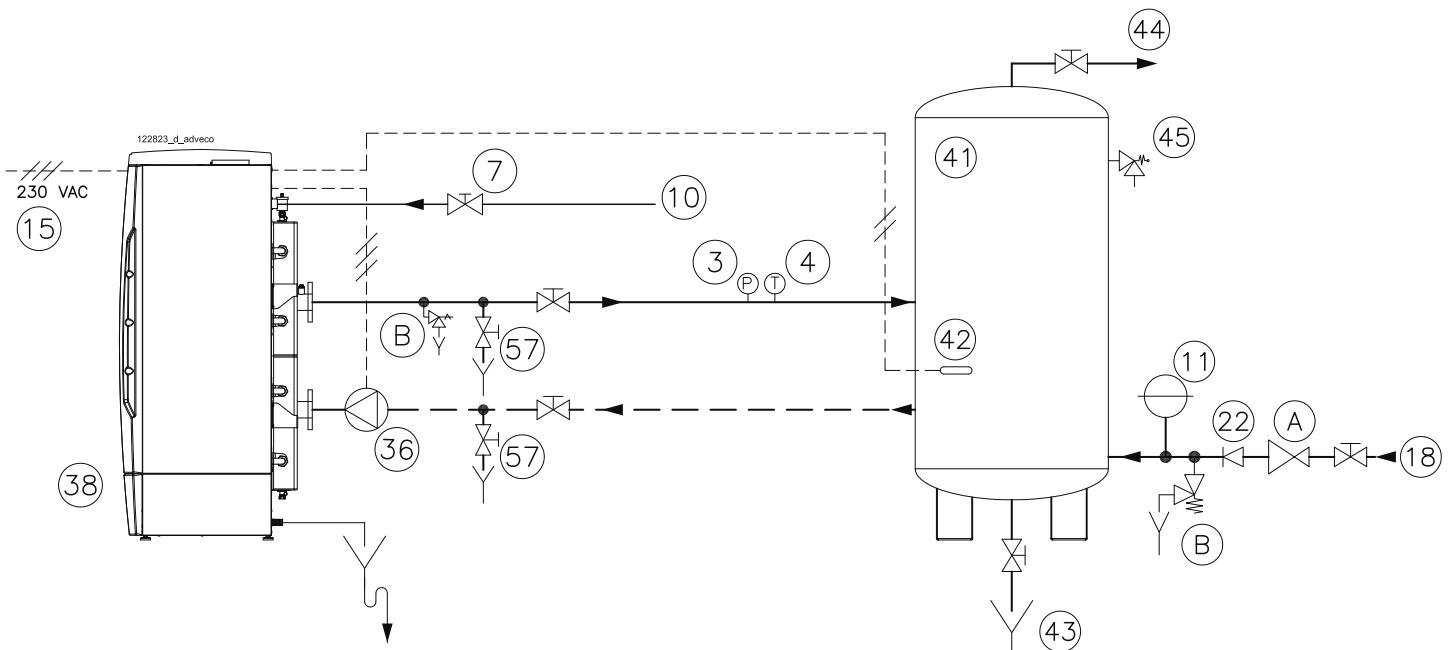

Figure 11-1 - Example of water heater connection diagram

- 3 INAIL manometer
- 4 INAIL thermometer
- 7 Gas cock
- 10 Gas inlet
- 11 Expansion tank
- 15 Electrical power supply
- 18 Domestic cold water
- 22 Check valve
- 23 -----
- 36 Domestic hot water circuit pump
- 38 Water heater 60T-280T model
- 41 Storage tank
- 42 Storage tank temperature sensor

- 43 Storage tank drain valve
- 44 D.H.W. outlet
- 45 Storage tank safety valve
- 57 Drain cock (Mandatory in the 70 and 140 models)
- A Pressure Reducing Valve
- B Expansion Relief Valve

11 - INSTALLATION - Hydraulic connections - water heater

11.4 - Expansion vessel

When installed on a sealed system, the installer must fit an expansion control system like an expansion vessel. Make sure that the expansion vessel is correctly sized for the volume of water contained in the water heater, buffer vessel and in the system (see section 18, "water contained in the main exchanger"). Consideration should also be given to the working temperature and pressure.



ATTENTION !!! The appliance does not have an integral expansion vessel. When connected to an unvented system an appropriately sized expansion vessel, suitable for domestic hot water circuits shall be fitted to comply with the relevant installation standards. An undersized expansion vessel can cause the safety valve to lift.

The expansion tank must be installed as shown in figure 11-1 or according to recognised design methods. Refer to the instructions of the expansion vessel manufacturer for further installation details.

11.5 - Circulation pump

This water heater must always be paired with a direct storage tank with a capacity of no less than 1 litre per kW of installed heat output. To heat the storage tank, a circulation pump suitable for domestic hot water must be installed. The water heater hydraulic resistance is shown in a graphic in figure 11-4.

To correctly size the pump, the designer must consider not only the water heater resistance, but also the storage tank resistance and the connection pipework system resistance. For the electrical connection of the pump, refer to figure 13-6.

If the selected pump has an current draw greater than 3A, install a suitable relay between the water heater and the pump.

11.6 - System sizing

Size the pump, the piping and every device necessary to the system following a recognised design method.



ATTENTION !!! It is the installer's responsibility to ensure that the minimum water flow rate to the water heater at any time is no less than what is described in section 18, "Minimum operating water flow rate". If the flow rate is lower, the appliance will stop automatically.

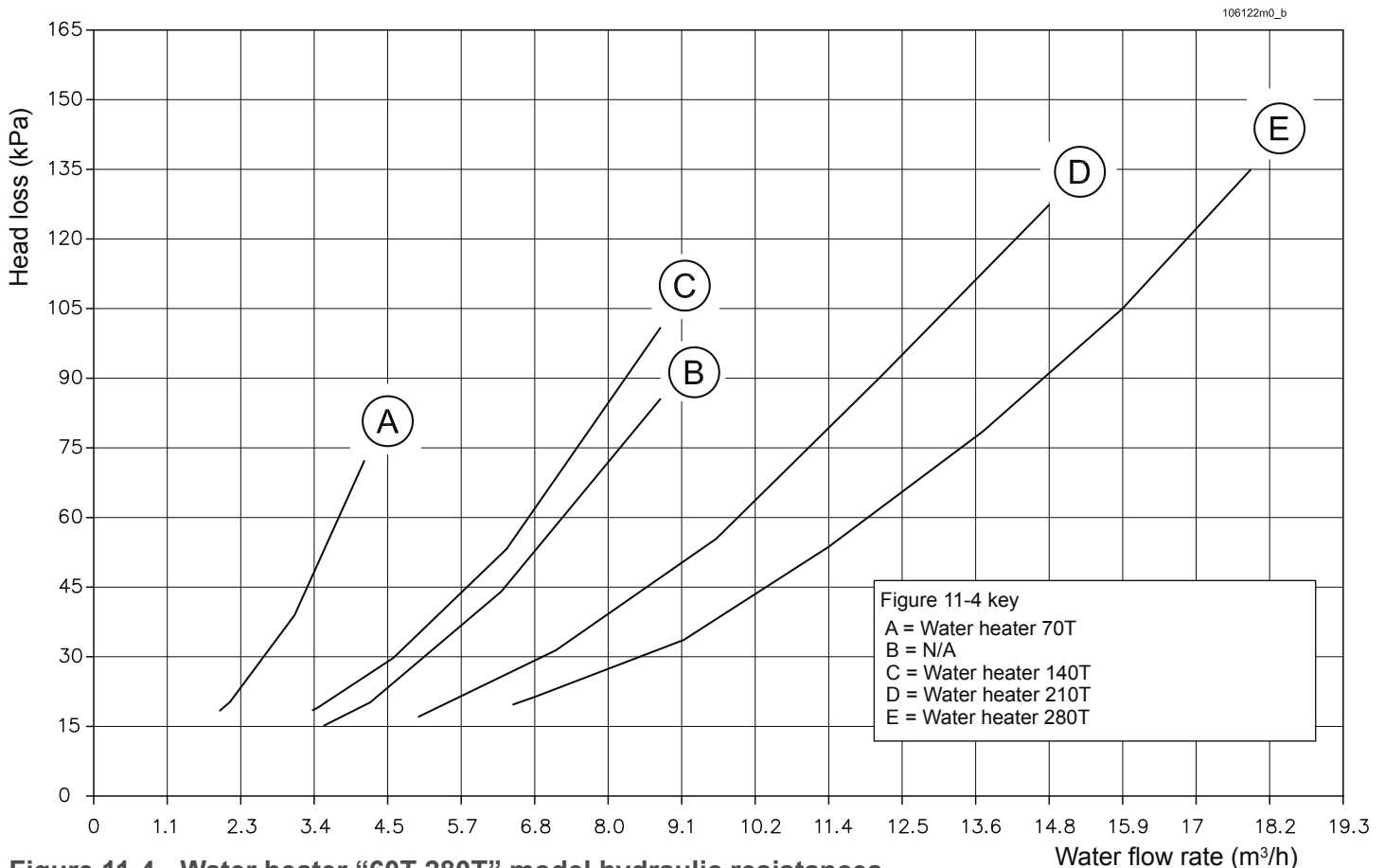

Figure 11-4 - Water heater "60T-280T" model hydraulic resistances

11 - INSTALLATION - Hydraulic connections - water heater

11.7 - Precautions against burns

ATTENTION !!! This water heater is able to supply water at temperatures up to 80°C. Be careful when using water heated by the water heater to prevent scalding.

The water heater should be adjusted to ensure that water is stored at a temperature greater than 60°C and a temperature of 50°C is achieved at all outlets within 1 minute. Excessive temperatures significantly increase the possibility of scalding with children and those with a sensory or mobility loss being at the greatest risk. Where the possibility of scalding has been identified, appropriate measures such as thermostatic mixing valves should be considered.



ATTENTION !!! The system downstream from the appliance must be made with materials suitable for temperatures up to 95°C and pressure of 10 bar. The system must be equipped with appropriate protection and safety devices to ensure the maximum operating characteristics of any component in the system are not exceeded.



ATTENTION !!! The system should be sized to achieve a minimum flow rate to the water heater relative to water hardness (Figure 11-5) to prevent limescale deposits inside the heat exchanger.

11.8 - Minimum and maximum water flow rate in the water heater



ATTENTION !!! Water with a hardness less than 53 ppm has a pH that can be harsh and corrosive and can damage the heat exchanger and/or the piping.



ATTENTION !!! Water quality must be within 6.5 and 8.5 pH acidity value. Values out of this range are corrosive, causing damage to the heat exchanger and/or heater piping.



ATTENTION !!! Install a metal mesh filter with a 0.5 mm² opening on the cold water inlet.



ATTENTION !!! The flow rate cannot be increased for hardness above 334 ppm. Erosion could occur inside the copper pipes that are used within the water heater to direct water to the heat exchanger.

Figure 11-5 also shows an example of how to interpret the graphic: if you have a 280T model water heater and the water hardness is 278 ppm, the minimum water flow that must go through the water heater is approximately 15 m³/h. The curves corresponding to each water heater model all end around 334 ppm of hardness.

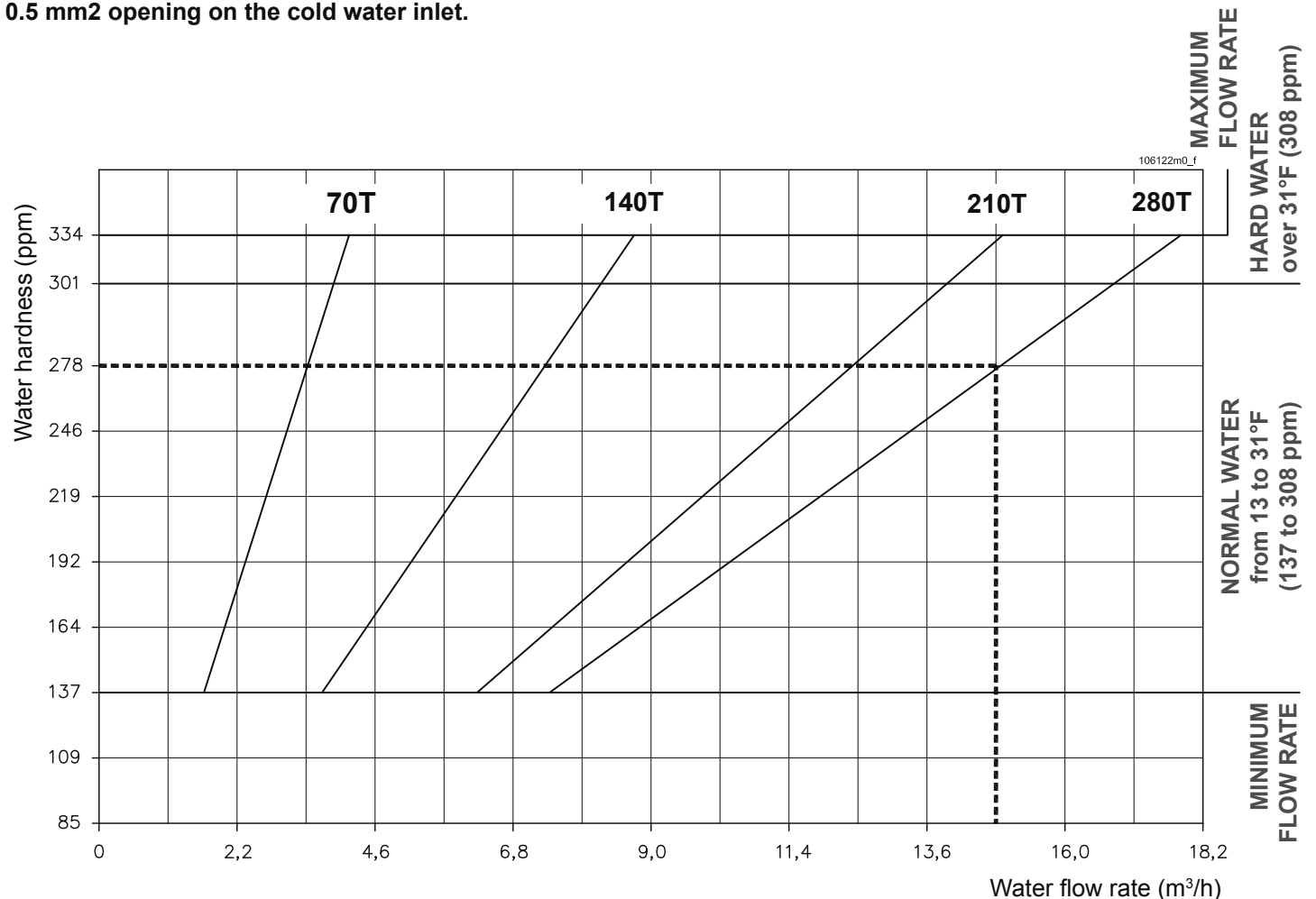

Figure 11-5 - Minimum and maximum flow rate limits inside the water heater according to water hardness

12 - INSTALLATION - Eliminating condensate

12.1 - Condensate drain

Inside the appliance, there is a siphon and condensate neutraliser system to evacuate condensate (see figures 3-3, 3-5 and 3-7, parts "2"- "3") and to prevent the combustion exhaust from escaping, the outlet of which corresponds to duct "5" referred to in figures 3-3, 3-5 and 3-7. This outlet must be directed into another anti-odour siphon (installer's responsibility) in order to prevent bad odours from coming back into the room.

In particular, the condensate disposal system must:

- ☞ be made with a pipe that has an inner diameter greater than or equal to 13 mm;
 - ☞ be installed so as to prevent the liquid from freezing; therefore, be aware of any sections passing outdoors. Draining into gutters or drainpipes is prohibited;
 - ☞ be in continuous incline towards the drain point; avoid high points that could put the duct under pressure;
- Figure 12-2 shows how a condensate disposal system must be made downstream of the appliance.

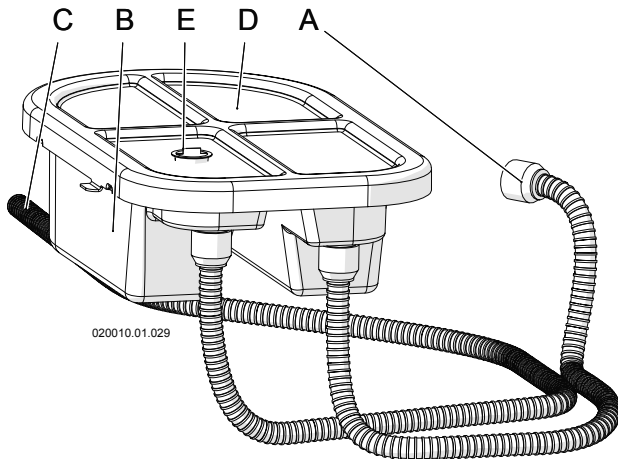

Figure 12-1 - Condensate neutraliser

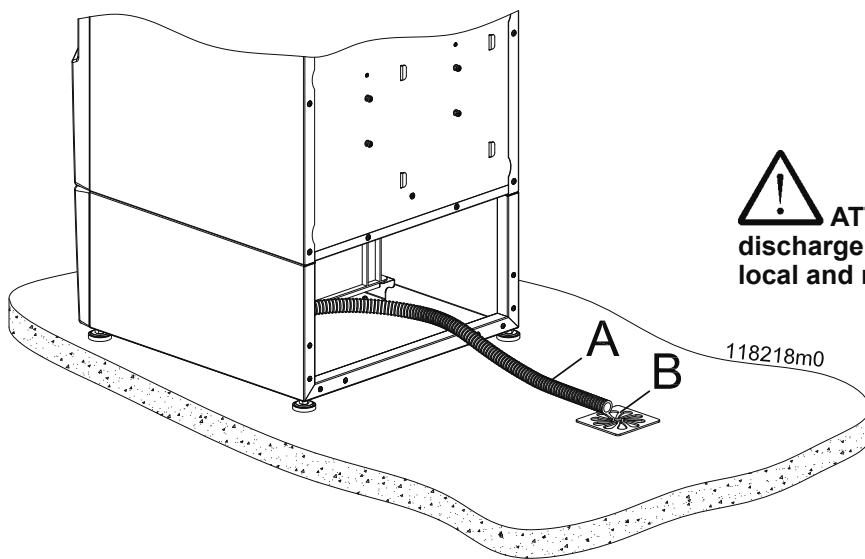

Figure 12-2 - Condensate drain

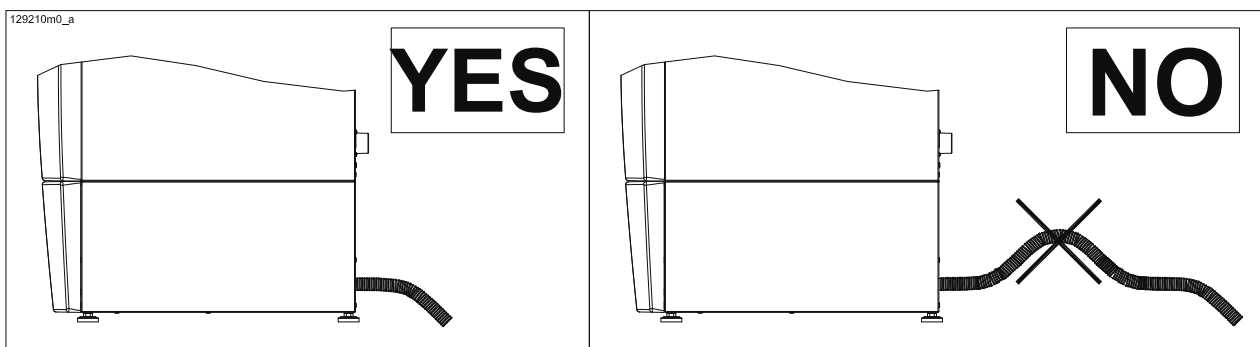

Figure 12-3 - Proper condensate drain pipe installation

13 - INSTALLATION - Electrical connections

13.1 - Electrical connections: general information



ATTENTION !!! Disconnect power before carrying out any operations inside the appliance.



ATTENTION !!! During maintenance, label all the wires involved in the operation before disconnecting.



ATTENTION !!! The appliance is only electrically safe when it is properly connected to a suitable earthing system installed in accordance with the relevant standards and regulations in force.

This fundamental safety requirement must be checked. In you have any doubts, ask a professionally qualified electrician to check the electrical system thoroughly.

- ☞ Have a professionally qualified electrician make sure that the electrical system is appropriate to the electrical power required by the appliance, shown on the plate.
- ☞ The appliance must be connected to the electrical mains through a fixed connection or through an un-switched plug connection. The use of adapters, power strips, extension cords, etc. is not allowed.
- ☞ The appliance must be connected to the electrical mains with a double insulated three-core cable or equivalent with appropriate cross-section.

☞ To connect to the electrical mains, provide a two-pole switch near the appliance with a contact opening distance of at least 3 mm, as required by the applicable standards in force.

☞ Respect the polarity between phase and neutral when connecting the appliance.

☞ Make sure the piping for the hydraulic, heating and gas systems is not used to ground the electrical or telephone system. This sort of piping is absolutely not appropriate for this purpose. In addition, the appliance, the piping and the radiators can suffer serious corrosion damage in a short time.



ATTENTION !!! The appliance has no protections against the effects of lightning.

13.1.1 - Connecting the power cable

To connect the electrical power cable, proceed as follows (refer to figure 13-1):

- 1.- use a double insulated three-core cable
- 2.- access the electrical connection terminal board following the specific instructions in section 17.2;
- 3.- secure the power cable using the cable gland near contacts "101", "102" and "PE";
- 4.- strip the cable, taking care to keep the grounding cable (green/yellow) 20 mm longer than the other two;
- 5.- connect the green-yellow cable to the ground terminal ("PE")
- 6.- connect the brown cable (Phase) to terminal "101"
- 7.- connect the blue cable (Neutral) to terminal "102"

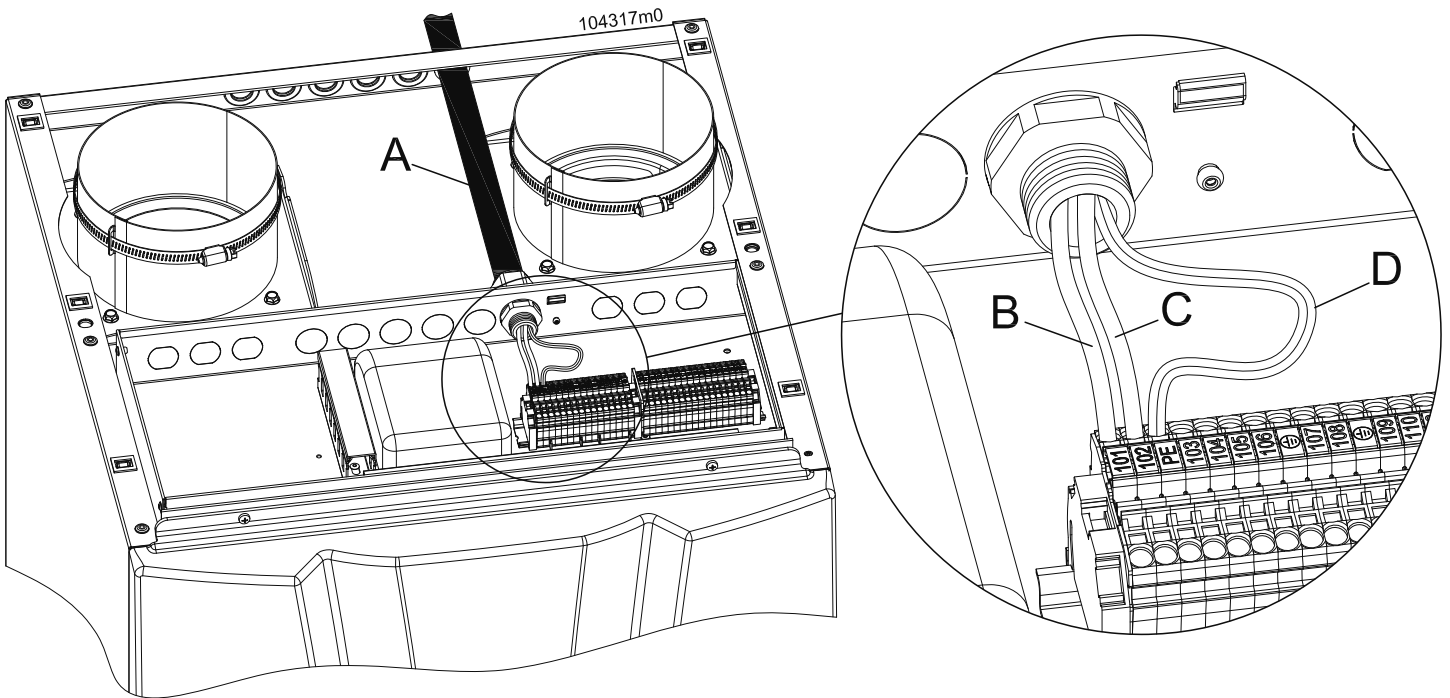

Key

- A = Electrical wire sheath;
- B = Line;
- C = Neutral;
- D = Earth.

Figure 13-1 - Electrical connections

13 - INSTALLATION - Electrical connections

13.1.2 - Choosing the room thermostat/ time-programmable thermostat

The boiler is equipped to work with any room thermostat or programmable thermostat that has a contact to connect to the cables coming from the boiler, with the following characteristics:

- open/closed (ON/OFF);
- volt free (not powered);
- closed when heat is required;
- minimum electrical rating of 24Vac, 1A.

13.1.3 - Connecting the room thermostat/ time-programmable thermostat

Install the room thermostat in a part of the building in which the temperature is as close as possible to the average temperature and in an area that is **not** subject to sudden drastic temperature changes, away from windows or doors that lead directly outdoors (see figure 13-2).

To connect the room thermostat cable, proceed as follows (refer to figures 13-4 and 13-5):

- 1.- use a two-core cable with 1.5 mm² minimum cross-section from the boiler to the room thermostat/programmable thermostat. The maximum allowed length is 100 metres; use a shielded cable with shield grounding;
- 2.- disassemble the boiler casing following the specific instructions in section 17.2;
- 3.- secure the electrical cable using the cable gland near contacts "10" and "11";
- 4.- use a free cable gland that is not used by other conductors;
- 5.- strip the cable;
- 6.- connect the 2 ends of the cable to terminals "10" and "11" (see figures 13-4 and 13-5).

 **ATTENTION !!! As the room thermostat/programmable thermostat cables are subjected to extremely low safety voltage (24Vdc), they must run in different ducts than 230Vac power cables.**

13.1.4 - Installing the external temperature sensor

Install the external temperature sensor outside the building on a wall facing NORTH or NORTH-EAST at a height from the ground of between 2 and 2.5 metres. Do not install it above windows, doors or air vents, nor directly underneath balconies or gutters. Do not plaster or clad over the external temperature sensor.

Should the sensor be installed on a wall that still needs to be plastered or clad, it must be installed with an appropriate spacer or removed before work commences.

To connect the external temperature sensor cable, proceed as follows:

- 1.- install a two-core cable with 1.5 mm² minimum cross-section from the boiler to the external temperature sensor. The maximum allowed length is 100 metres; use a shielded cable with shield grounding;



ATTENTION !!! As the cables are subjected to extremely low safety voltage (24Vdc), they must run in different ducts than 230Vac power cables.

- 2.- connect the two-core cable to terminals "14" and "15" shown in figures 13-4 and 13-5;
- 3.- connect the two-core cable to the ends of the external temperature sensor.

Set the boiler to recognise the external temperature sensor as follows:

- 4.- access the "installer menu" as described in section 16.15 and set the parameter 2003 = 1.

The  icon on the display confirms that the external temperature sensor is enabled.

Proceed with the steps in section 16.9.1 to set the correct supply temperature adjustment values based on the external temperature.

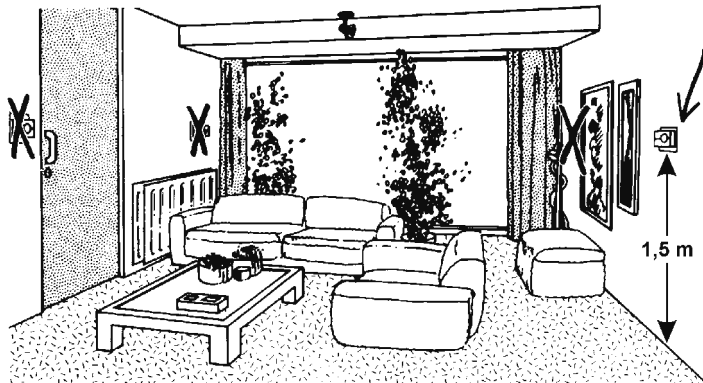

Figure 13-2 - Correct room thermostat/controllable thermostat positioning

13 - INSTALLATION - Electrical connections

13.1.5 - 885 IF board connection

The 885 IF board is supplied for all models (see part "13" in figures 3-3, 3-5 and 3-7).

The board allows:

- 1.- the appliances to be controlled via 0-10Vdc analogue signal;
- 2.- the appliances to be controlled via MODBUS communication digital signal;
- 3.- up to 8 appliances to be connected in cascade (see section 13.4)

0-10 VDC control

The 885 IF board allows the appliance to be controlled via 0-10 VDC input, proceeding as follows:

- 1.- Access the "installer menu" as described in section 16.15 and set the parameter 2003 = 4.
- 2.- The appliance can now be controlled via 0-10 VDC signal as shown in figure 13-3;

MODBUS type dialogue

The 885 IF board allows the appliance to be controlled via MODBUS dialogue. Please refer to the separate instructions for further details.

13.1.6 - Alarm contact

Alarm contact does not react in case a dependent module (burner 2, 3 or 4) is in error.

13.2 - Connecting boiler to the storage tank

In order to generate domestic hot water, the boiler must be connected to an indirect storage tank.

The hydraulic connection must be installed as per figure 10-2 or or equivalent.

For the electrical connection, proceed as follows (refer to figures 13-4 and 13-5):

- 1.- disconnect power to the boiler;
- 2.- lay a two-pole electrical cable with 1.5 mm² minimum cross-section going from the boiler to the storage tank temperature sensor and connect it on the boiler to terminals "12" and "13" (SB);
- 3.- connect the other end of the cable to the storage tank temperature sensor;
- 4.- put the temperature sensor inside the storage tank well (see figure 10-2, part "31").
- 5.- set parameter 3012 to "1" (see section 19)
- 6.- electrically connect the storage tank pump to terminals 107 and 108 of the boiler (see figures 13-4 and 13-5).

The temperature of the water stored inside the storage tank can be selected by the user within a 40-60°C range.



ATTENTION !!! The water heater should be adjusted to ensure that water is stored at a temperature greater than 60°C and a temperature of 50°C is achieved at all outlets within 1 minute. Excessive temperatures significantly increase the possibility of scalding with children and those with a sensory or mobility loss being at the greatest risk. Where the possibility of scalding has been identified, appropriate measures such as thermostatic mixing valves should be considered.

13.2.1 - D.H.W. production priority

The boiler comes out of the factory set with full priority given to domestic hot water production. This means that the boiler works in domestic mode until the required temperature in the connected storage tank is reached. If the recovery time of the hot water storage tank is too high, this setting could lead to cooling of the building. Once the domestic hot water demand is met, the appliance automatically goes back to serving the space heating demand.

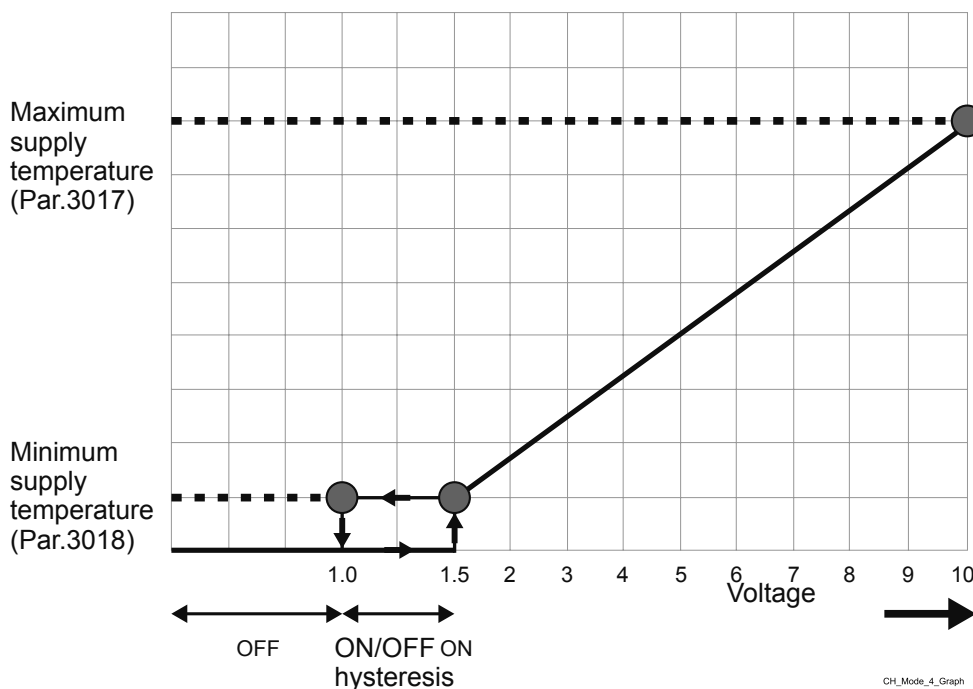

Figure 13-3 - 0-10 Vdc analogue input operating rules

13.3 - Connecting water heater to the storage tank

The water heater must be connected to a direct storage tank.

The hydraulic connection must be done as per figure 11-1. For the electrical connection, proceed as follows (refer to figure 13-6):

- 1.- disconnect power to the water heater;
- 2.- Access the connection electrical terminals;
- 3.- Disconnect the manifold temperature sensor from terminals "8" and "9";
- 4.- Install a two-core electrical cable with 1.5 mm² minimum cross-section from the water heater to the storage tank. Connect the cable at the water heater to terminals "8" and "9" (Manifold temperature sensor);
- 5.- connect the temperature sensor– supplied with the water heater – to the installed cable;
- 6.- fit the storage tank temperature sensor into a pocket in the storage tank (see figure 11-1, part "42").

The temperature of the water stored inside the storage tank can be selected by the user within a 40-80°C range

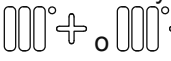
using the  heating temperature adjustment controls, as described in section 16.5.



ATTENTION !!! A water temperature exceeding 51°C can cause even permanent harm to persons, animals and objects. Above all, children, the elderly and the disabled must be protected against the potential risk of scalds by putting in devices that limit the temperature of domestic hot water use to the domestic utilities.

13 - INSTALLATION - Electrical connections

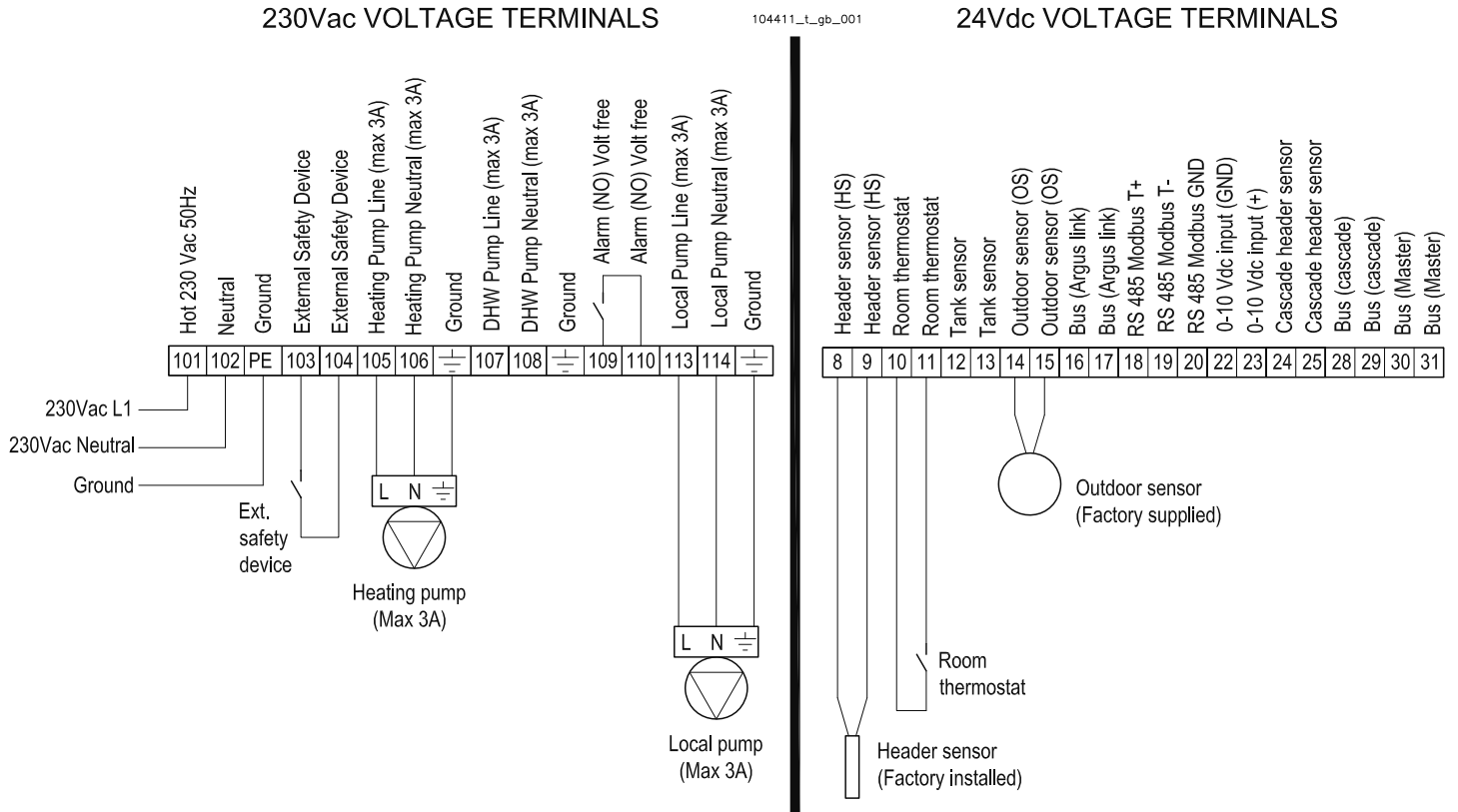

Figure 13-4 - Boiler electrical connections (Example of system shown in figure 10-1)

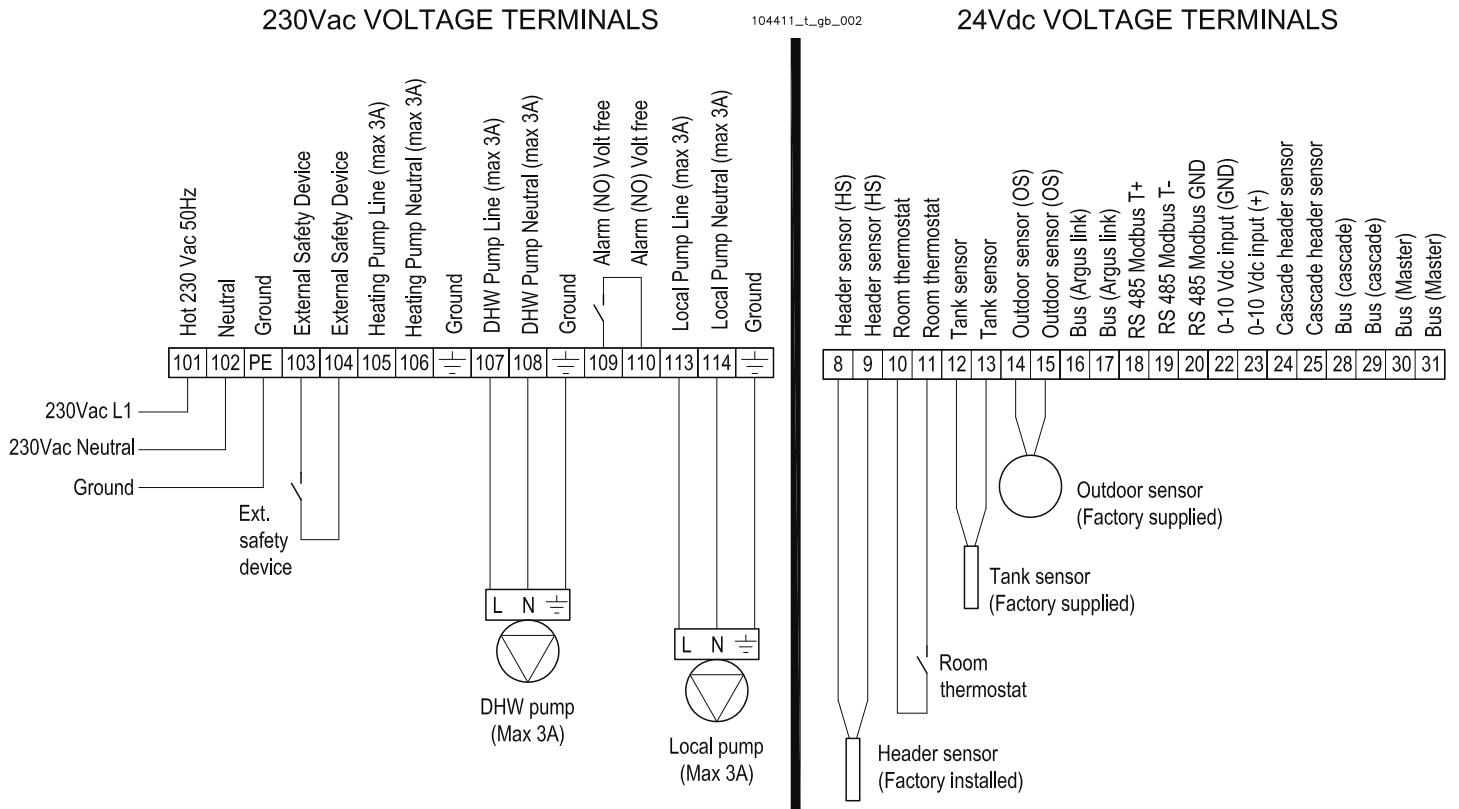
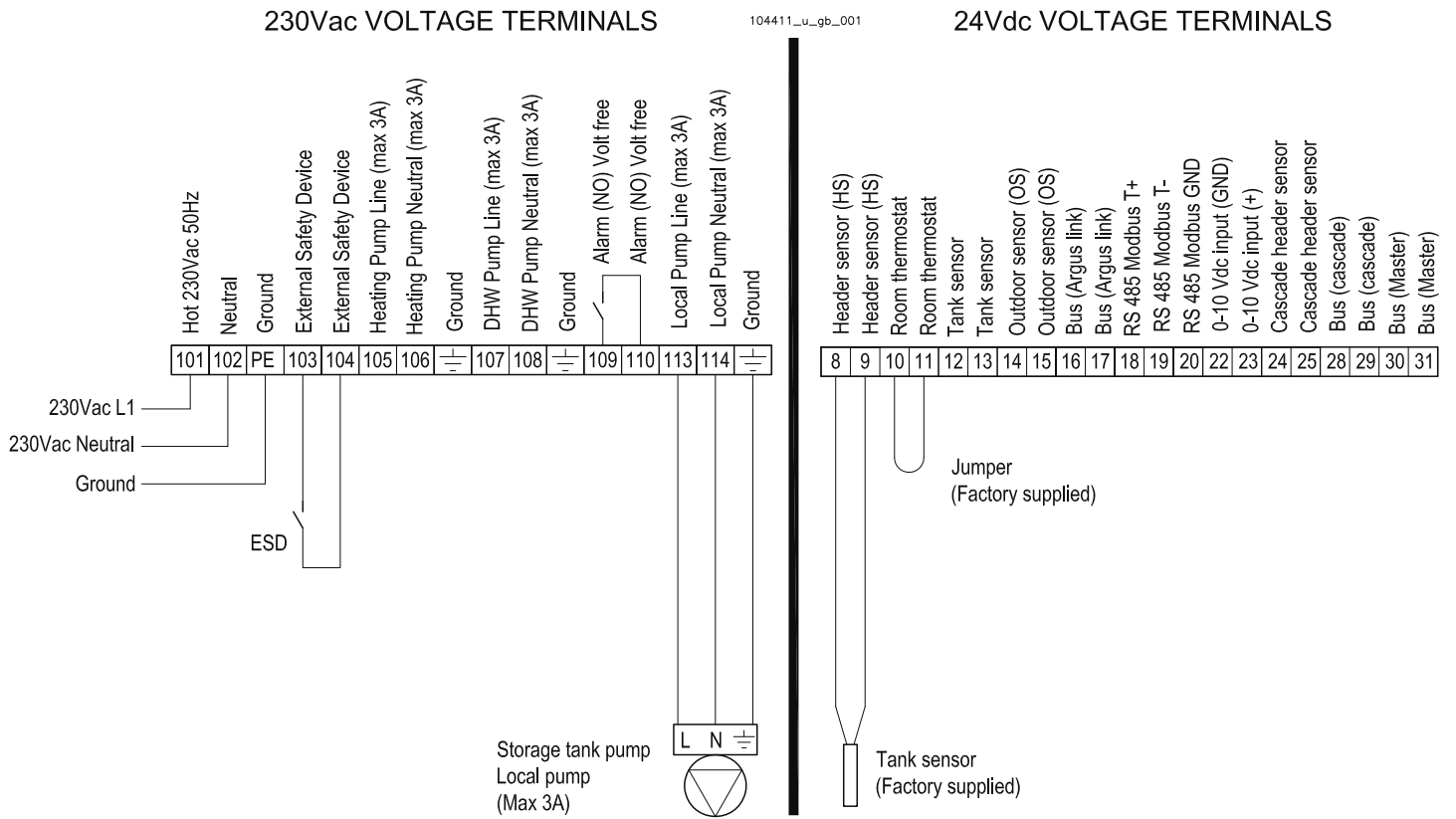

Figure 13-5 - Boiler electrical connections (Example of system shown in figure 10-2)

13 - INSTALLATION - Electrical connections



13.4 - Connecting cascade appliances

Connecting cascade appliances is done as shown in the diagrams in figure 13-7 (boiler) and 13-8 (water heater).

For the cascade to function, the 885 HC cascade control (see figures 13-7 and 13-8) must be purchased.

At most 8 appliances can be connected in cascade (figures 13-7 and 13-8 show examples with 4).

Follow the 885 HC control manual for instructions on connecting the appliances in cascade.

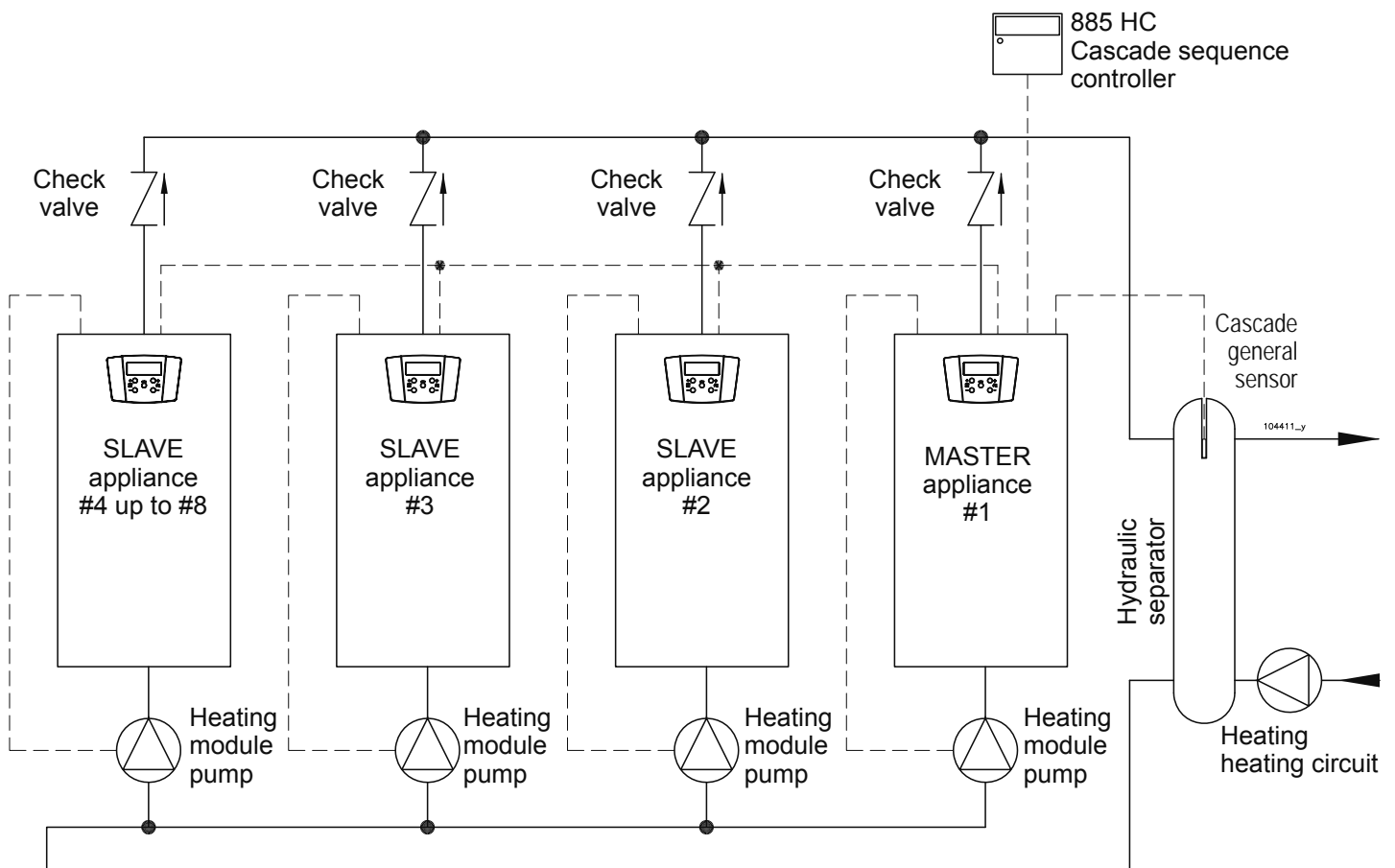

Figure 13-7 Boiler appliances in cascade connection conceptual diagram

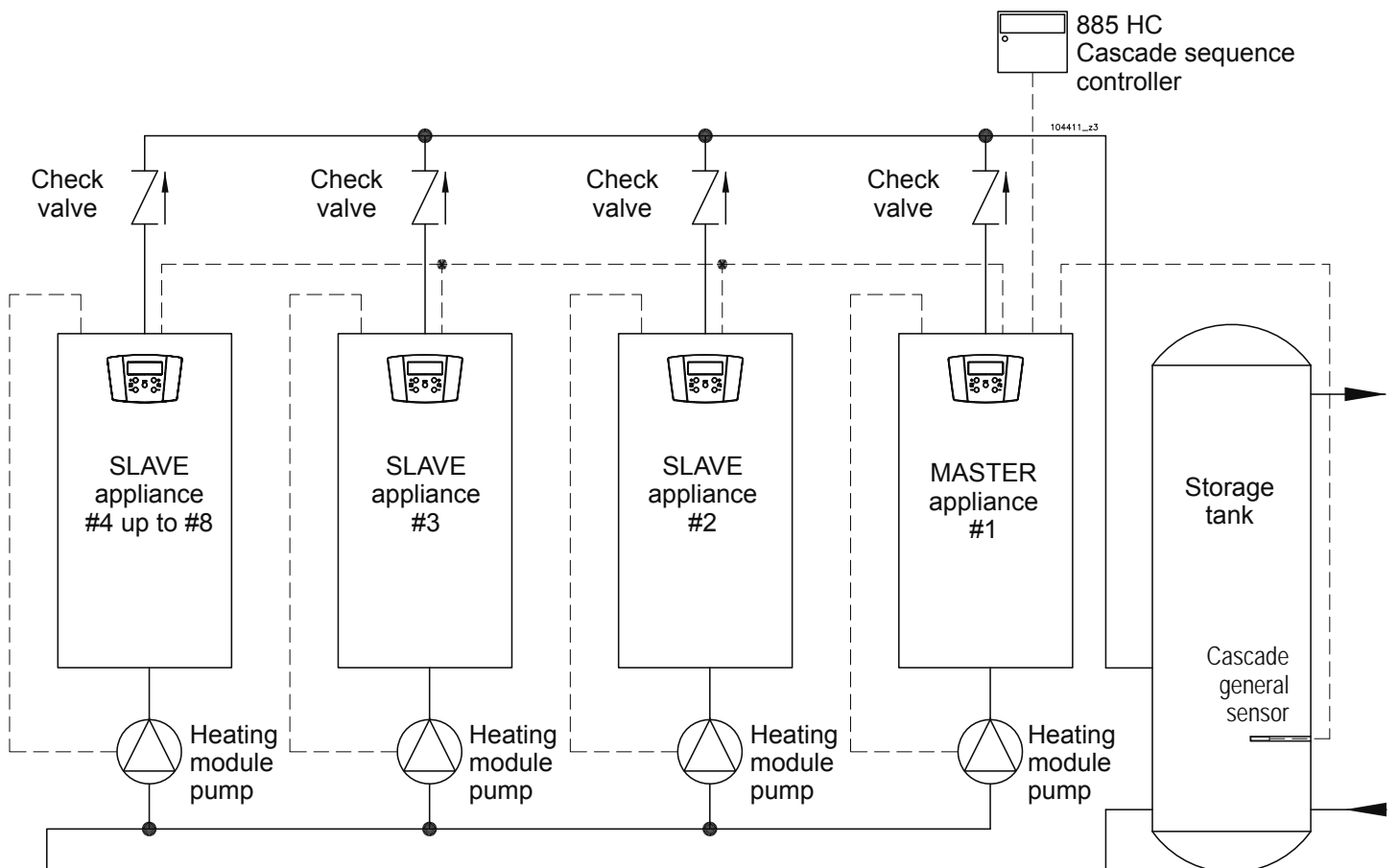





Figure 13-8 Water heater in cascade connection conceptual diagram

14 - INSTALLATION - Air intake and flue exhaust ducts

14.1 - Flue exhaust and combustion air intake duct

 **ATTENTION !!! This appliance must be connected to a flue system that evacuate the products of combustion to the open air outside of the building.**

 **ATTENTION !!! The flue system and combustion air intake must be terminated in accordance with the national and local regulations and standards in force.**

 **ATTENTION !!! This appliance has flue gas temperatures that can reach 90°C under certain conditions. Therefore, use flue exhaust ducts in plastic that can resist said temperature.**

 **ATTENTION !!! This is a condensing appliance. The flue system shall be constructed from suitable grade of stainless steel or polypropylene plastic materials to prevent corrosion due to condensate acidity.**

It is recommended that exhaust and intake ducts supplied by the manufacturer of the appliance itself. Other types of ducts, if used, must be approved for such intended use. The types of exhaust for which the appliance is approved are shown on the technical features table at the end of the manual, under the "type" heading and on the plate affixed to the boiler, again under the "type" heading.

The symbols used to define the type of exhaust are shown below:

- B23, an appliance intended to be connected to a flue that evacuates the products of combustion to the open air outside of the building. The air for combustion is drawn directly from inside the plant room.

 **ATTENTION !!! If you install an appliance with a B23 type exhaust, it will draw air for combustion from the room in which it is located. It is essential that natural or mechanical ventilation, as required by national and/or local standards is installed.**

- C53, an appliance that is sealed from the room in which it is installed by separate ducts for air supply and exhaust discharge. The ducts may discharge horizontally or vertically, in different pressure zones but shall not be on opposite walls of the building.

- C63, the appliance can be connected to a flue and air intake system that meets the minimum requirements detailed in section 18 and is installed in one of the configurations listed above.

 **ATTENTION !!! With the C63 type exhaust, additional condensate drains must be installed to ensure that the condensate from the chimney cannot enter the boiler.**

During operation, especially in the winter, it is possible for a condensation plume to form at the appliance terminal. This is a natural phenomenon and no cause for concern as it is the water vapour in the flue gases that condense when cooled by the external air.

14.1.1 - B23 suction/discharge type

In the event of B23 type combustion air intake/flue exhaust, it is essential that sufficient allowances for combustion air are made. The combustion air shall be taken from outside either through natural or mechanical means.

The location of the air intake should be away from sources of pollution such as industrial air extraction systems, swimming pool ventilation systems and cleaning chemicals such as laundry discharges. Further details on ventilation requirements and allowances can be found in sections 5.1.1 and 5.2.2.

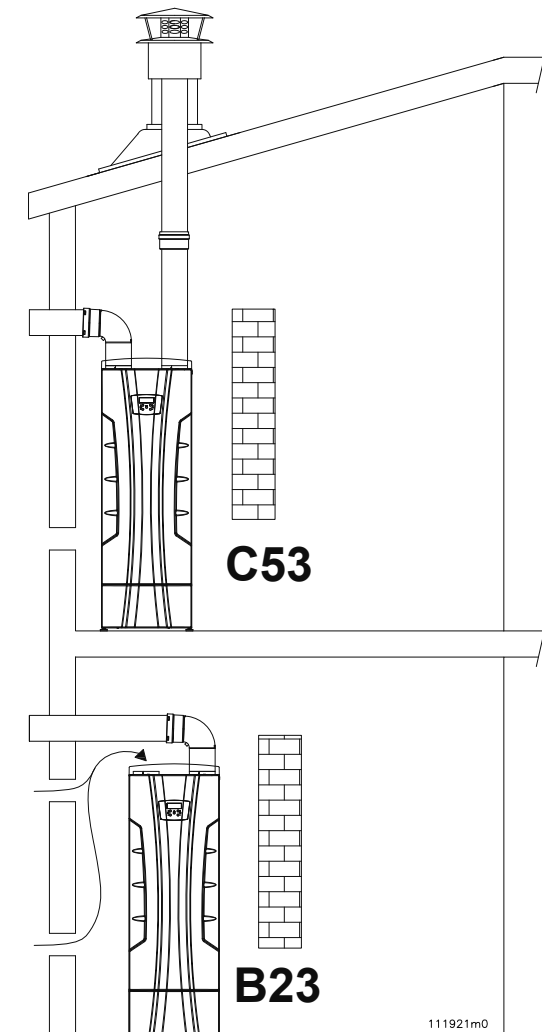

Figure 14-1 - Exhaust/intake systems

14 - INSTALLATION - Air intake and flue exhaust ducts

14.1.2 - Split system

The appliance is standard supplied with fittings to connect to the flue exhaust and air intake. To install, proceed as shown in figure 14-2.

- 1.- put duct "D" in fitting "A" and secure it using the tightening clamp in fitting "A";
- 2.- reducer "C" is standard assembled on fitting "B";
- 3.- put duct "E" into reducer "C", being sure that the gasket in reducer "C" is positioned correctly;

☞ The flue system and air intake should be constructed from a suitable grade of stainless steel or from polypropylene that is resistant to condensate and rated to a minimum temperature of 120°C.

☞ Flue ducts that pass through building structures should be sleeved with a 25 mm air gap to meet the minimum requirements of local and national regulations in force. The sleeve should allow the flue to be removed in order to complete any normal maintenance that is required.

☞ The horizontal sections must always have a slope of at least 2% towards the condensate drain devices.

☞ The appliance is factory fitted with a condensate neutraliser, which must be joined to a suitable drainage system (see section 12).



ATTENTION !!! The factory fitted condensate drain is designed to allow all of the condensate produced by an individual appliance flow out. Should multiple appliances be installed, each must use its own condensate drain.

The flue exhaust/air intake system can be extended up to a maximum distance as instructed in section 18. Each 90° curve has a loss equivalent to what is described in section 18.



ATTENTION !!! The flue exhaust outlet must be appropriately protected against the effects of the wind.



ATTENTION !!! Mechanically secure the joints between the various exhaust and intake duct components using fixing or equivalent systems. See figure 14-4.



ATTENTION !!! The temperature of the exhaust pipe during operation can reach 90°C. If they cross through walls that are sensitive to these temperatures, put in a protective heat insulating sheath.



ATTENTION !!! If the air intake and flue exhaust outlets are positioned on the same wall, they must be at least 1 metre away from each other.



ATTENTION !!! The exhaust and intake ducts must be appropriately supported via rigid brackets positioned no more than 1 m from each other unless otherwise stated by the manufacturer of the flue system. The brackets must be secured to rigid structures that can support the weight of the duct itself.

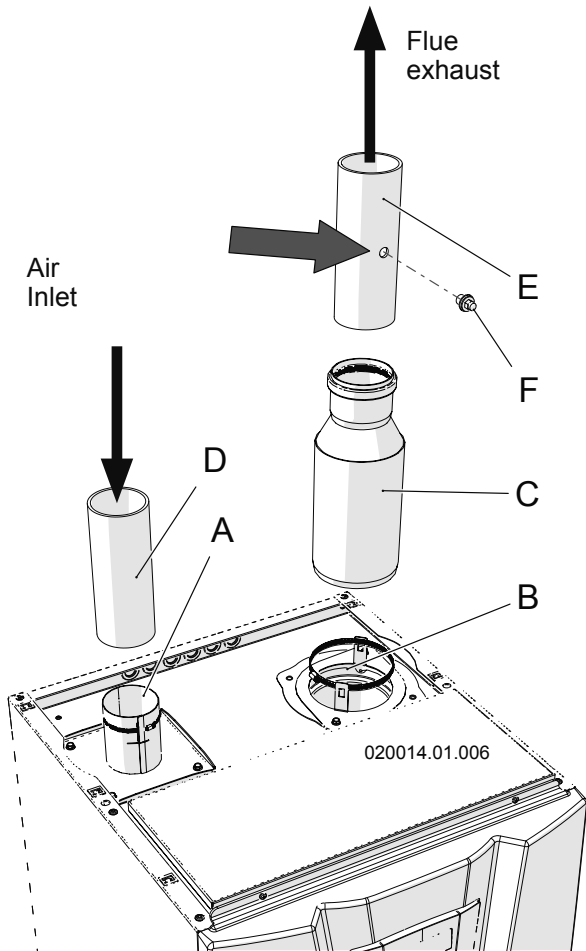

Figure 14-2 - Split system installation

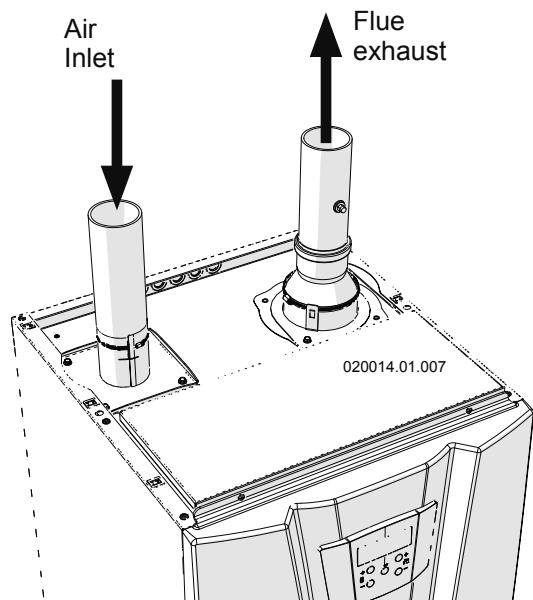

Figure 14-3 - Assembled system

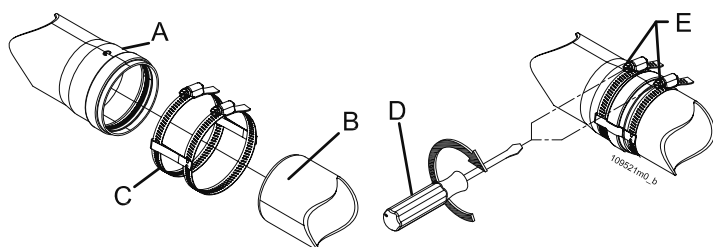

Figure 14-4 Securing exhaust and intake ducts

15 - COMMISSIONING

15.1 - Commissioning

Before commissioning the appliance, the following operations must be done.

15.1.1 - Filling the condensate drain siphon

The water trap located inside the appliance must be filled with water to prevent flue gases from escaping out of duct "5" in figures 3-3, 3-5 and 3-7.

To fill the water trap, proceed as follows:
(refer to figure 15-1)

- 1.- unscrew and remove plug "A" shown in the figure;
- 2.- put a rubber hose into opening "S" and position a funnel at the other end of the hose;
- 3.- slowly pour about 5 litres of water through the funnel;
- 4.- reassemble everything in reverse order.

 **ATTENTION!!!** If the boiler is switched off for more than 3 months, the water trap must be recharged as explained above.

 **ATTENTION!!!** Once the appliance is operating, make sure no flue gases are escaping from plug "A".

15.1.2 - Filling the heating system

When the appliance is switched on, if Err 59 appears on the display, it means that the system needs to be filled. Proceed as follows:

 only use clean water from the water mains.

 **ATTENTION!!!** Chemicals such as inhibitors etc. must be added as per the instructions on the product. Chemicals must not be poured directly into the boiler.

 **ATTENTION!!!** for direct water heaters, adding chemicals such as antifreeze is absolutely prohibited. The addition of chemicals to wholesome water could cause serious harm to human health or even death.

- 1.- open the air bleed valve (part "35" in figure 3-7)
- 2.- open the filling device - provided by the installer - upstream of the appliance and fill the system until the pressure sensor detects a pressure of 1.5 bar, shown on the display (part "M" in figure 16-1) (Err 59 appears on the display); If you wish to increase the minimum filling pressure level, parameter 3022 must be set to the desired value (see section 19);
- 2.- check the system for leaks and repair as necessary;
- 3.- close the filling device provided by the installer - upstream of the appliance;
- 4.- bleed the individual heat exchangers through their respective bleed valves (part "39" in figure 3-1);
- 5.- check the pressure on the display again (part "M" in figure 16-1). If it has gone down, fill the system to 1.5 bar again (or up to the set value).

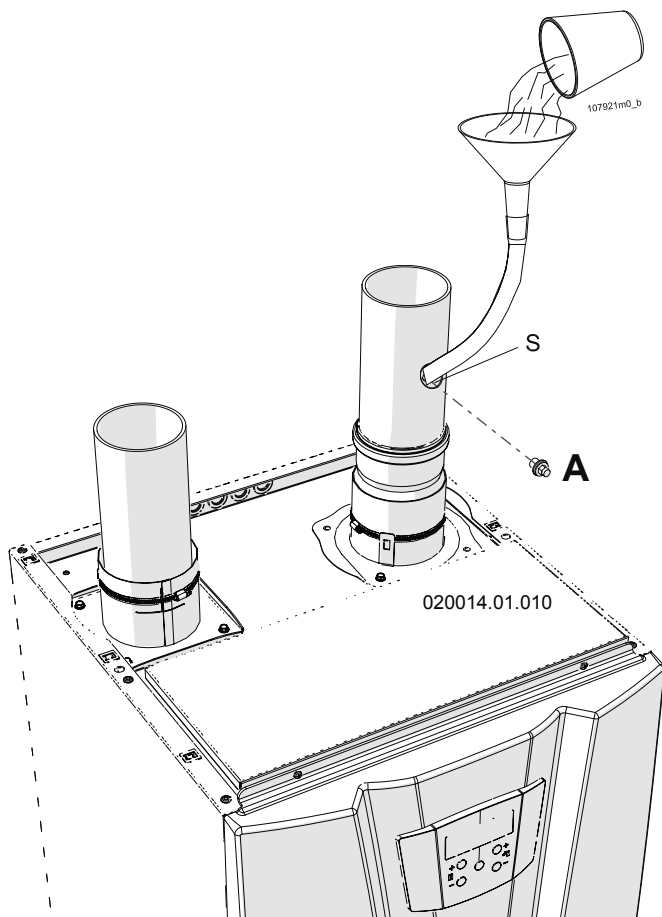

15-1 - Filling the condensate drain siphon

15 - COMMISSIONING

15.2 - General warnings on the gas power supply

Before first commissioning of the appliance, complete the following checks:

- ☞ That it is set for the type of fuel for which it is supplied.
- ☞ That the gas supply pressure is within the maximum and minimum values shown in section 18.
- ☞ That the gas supply system is equipped with all the safety and control parts required by the national and local standards in force.
- ☞ That the flue exhaust outlet and the combustion air intake outlet are free of any obstructions.
- ☞ That the flue exhaust and combustion air intake outlets are positioned in suitable locations outside the building.
- ☞ That the condensate drain is connected.



ATTENTION !!! Supplying the appliance with a different type of gas than those on which it has been certified is strictly prohibited.



ATTENTION !!! Make sure the gas type and supply pressure are those for which the appliance has been set or converted.

The appliance is equipped with the specific gas conversion kit.

- ☞ Before installation, it is advisable to thoroughly clean the gas supply pipework;
- ☞ it is mandatory to always install an appliance isolation valve on the gas supply pipe;
- ☞ tightness testing should be carried out using the procedures and pressures relevant to the size and volume of the gas supply pipework;
- ☞ if the gas system test must be run at pressures exceeding 50 mbar, use the isolating valve located immediately upstream of the appliance disconnect it from the rest of the system.

The location of the appliance gas connection is shown in figures 8-1, 8-2, 9-1 and 9-2. The size of the gas supply system must always ensure sufficient gas supply to cover the maximum required flowrate. Further guidance on pipe sizes can be found in IGEM/UP/2 Edition 3.



ATTENTION!!! If you smell gas:

- A - Turn off the gas supply at the gas meter;**
- B - Extinguish all naked flames – do not smoke or strike matches;**
- C - Do not operate electrical appliances or switches such as a light switch.**
- D - Open all doors and windows to ventilate the property.**
- E - Call the gas emergency service and follow their directions.**

15.3 - Type of gas for which the appliance is regulated.

There is a label on the front of the appliance bearing the gas supply type and pressure for which the appliance is regulated.

The appliance can have the following 2 phrases:

2H-G20-20mbar NATURAL GAS

it means the appliance is regulated to work with type H second family gas (Natural Gas) at a supply pressure of 20 mbar.

3P-G31-37mbar L.P.G.

it means the appliance is regulated to work with type P third family gas (propane, also known as LP gas) at a supply pressure of 37 mbar.

15 - COMMISSIONING

15.4 - Converting 70T model appliances from one type of gas to another



ATTENTION !!! Read these instructions carefully before changing the gas type:

- The gas equipment must be installed, calibrated or modified by a competent person;
- Check and be sure that the type of gas that is supplying the appliance is compatible with the regulation kit you have;
- Do not supply the appliance with a different type of gas than those provided for.

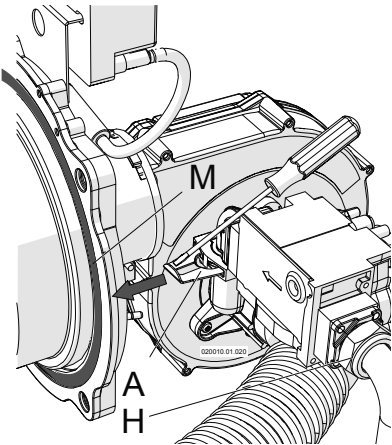

Figure 15-2 - Gas valve disassembly

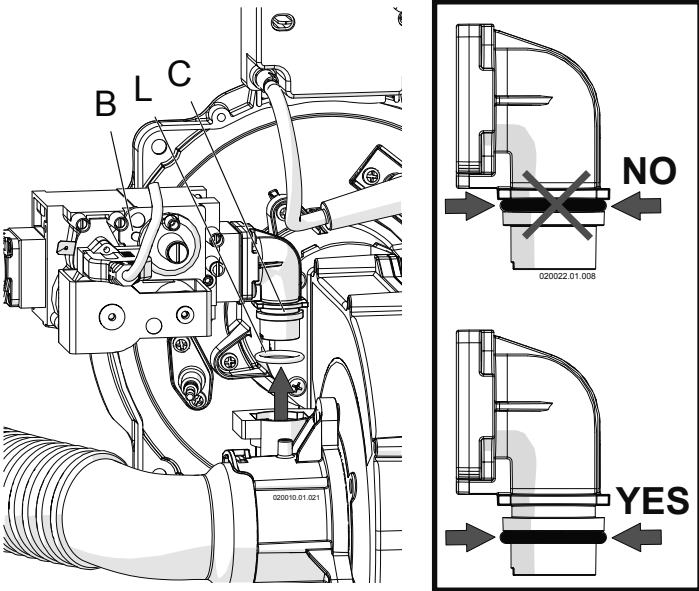

Figure 15-3 - Gas valve lifting

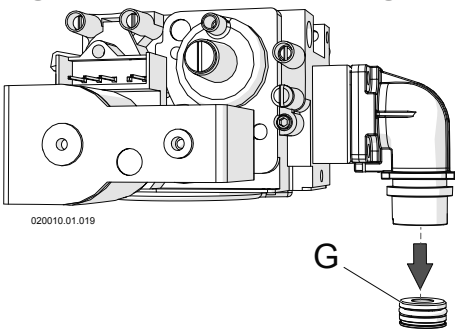

Figure 15-4 - Gas nozzle replacement

Contents:

The kit (supplied as standard with the appliance) is made up of - a label bearing the new type of gas, a gas nozzle for each burner and an instruction sheet;

To change the gas, proceed as follows:

- 1 - Switch off the appliance by turning the main switch to the OFF position (part "T" in figure 16-1);
- 2 - Close the gas supply isolation valve;
- 3 - open the boiler casing as described in section 17.2;
- 4 - Unscrew fitting "H" in figure 15-2;
- 5 - With the help of a screwdriver, remove fork "A" in figure 15-2;
- 6 - Remove the gas valve with fitting "C" as in figure 15-3 (being careful of O-ring "L" in figure 15-3);
- 7 - Replace nozzle "G" in figure 15-4 with the one in the kit, checking table 15-8 to make sure the diameter corresponds;
- 8 - Reinstall the gas valve, taking care to correctly position O-ring "L" in figure 15-3 and the gasket of fitting "H" in figure 15-2;
- 9 - Reposition fork "A" in the locking seat;
- 10 - Screw on fitting "H" in figure 15-2;
- 11 - Open the gas supply isolation valve;
- 12 - Use a leak detection fluid to make sure there are no leaks from fitting "H" in figure 15-2;



ATTENTION !!! Only use a leak detection fluid when checking for leaks; using naked flames is absolutely prohibited.

- 13 - Switch on the appliance by turning the main switch to the ON position (part "T" in figure 16-1);
- 14 - Completely unscrew screw "E" in figure 15-6 anticlockwise;
- 15 - Check the gas pressure, as described in section 15.7; the minimum pressure must not be less than 10 mbar, while the maximum must not exceed 45 mbar;
- 16 - Check and regulate the CO₂ following the procedure referred to in section 15.8 and checking the value in figure 15-8;



ATTENTION !!! The measurements must be taken with calibrated, guaranteed instruments that ensure an accurate reading.

- 17.- Check the appliance output heat as described in section 15.9;
- 18.- The gas conversion kit contains self-adhesive labels for the indication of the new gas supply type. The correct label must be selected and applied to the appliance in a prominent location, next to the rating plate where possible. If the appliance has been converted to LPG, "Section B" of the label should be applied; if the appliance has been converted to Natural Gas, "Section A" should be applied.



ATTENTION !!! If you smell gas:

- A - Turn off the gas supply at the gas meter;
- B - Extinguish all naked flames – do not smoke or strike matches;
- C - Do not operate electrical appliances or switches such as a light switch.
- D - Open all doors and windows to ventilate the property.
- E - Call the gas emergency service and follow their directions.

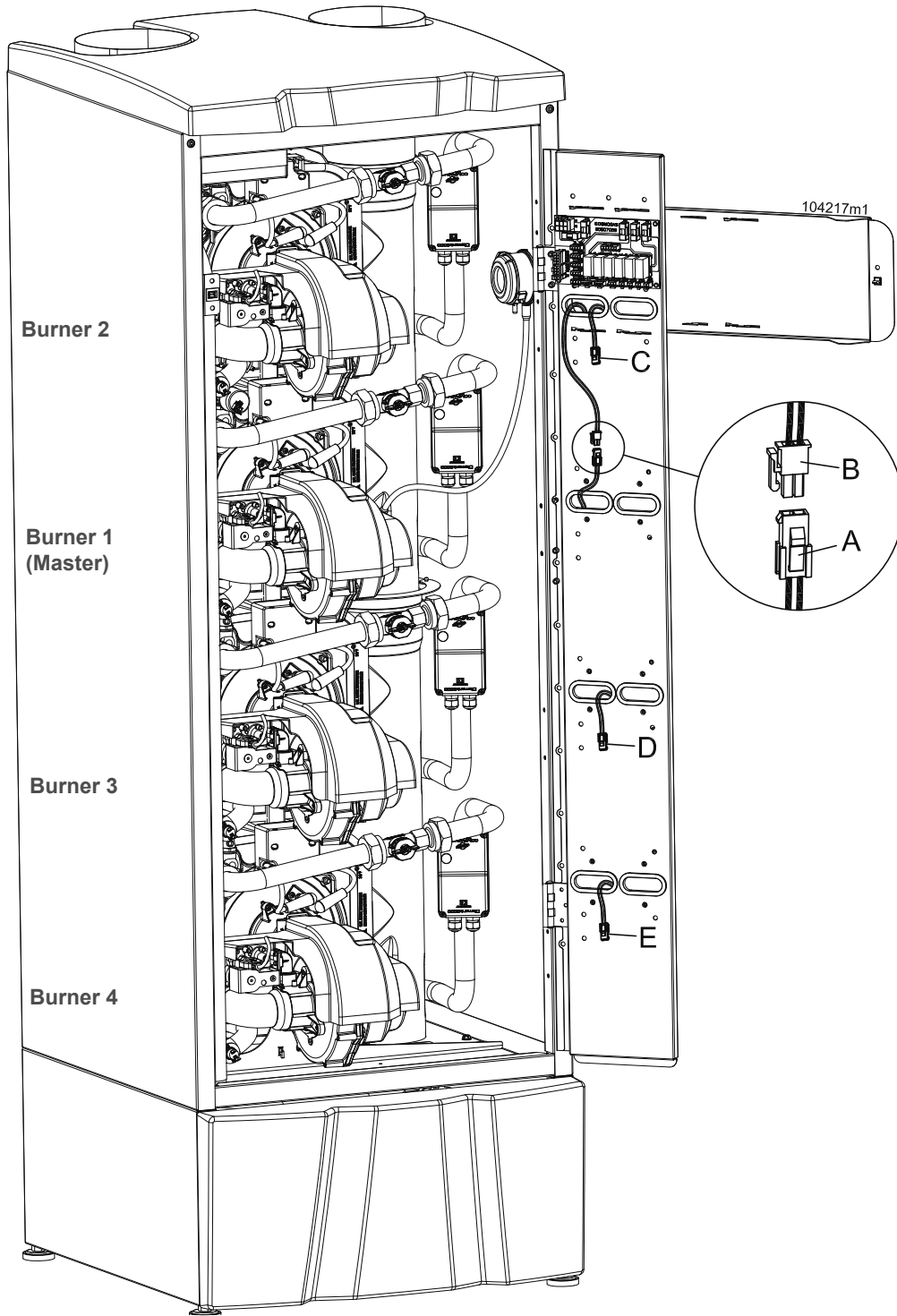

- A - Connector from Burner 1 (MASTER)
- B - Connector from display
- C - Connector from Burner 2
- D - Connector from Burner 3
- E - Connector from Burner 4

Figure 15-5 - Burner Position

15 - COMMISSIONING

15.5 - Converting appliance models from 140T to 280T from one type of gas to another

Appliances from 140T to 280T are multi-burners, which means that the type of gas must be converted on every burner.



ATTENTION !!! Read these instructions carefully before changing the gas type:

- The gas equipment must be installed, calibrated or modified by a competent person;
- Check and be sure that the type of gas that is supplying the appliance is compatible with the regulation kit you have;
- Do not supply the appliance with a different type of gas than those provided for.

Contents:

The kit (supplied as standard with the appliance) is made up of

- a label bearing the new type of gas;
- a gas nozzle for each burner;
- an instruction sheet;

To change the gas, proceed as follows:

- 1 - Convert "Burner 1" (MASTER). See figure 15-5 to identify "Burner 1" (MASTER);
- 2 - Convert "Burner 1" (MASTER), following points 1 to 16 in section 15.4;

After converting "Burner 1", proceed with "Burner 2" as described below:

- 3 - Convert "Burner 2", following points 1 to 16 in section 15.4;

After converting "Burner 2", proceed with "Burner 3" (if present) as described below:

- 4 - Convert "Burner 3", following points 1 to 16 in section 15.4;

After converting "Burner 3", proceed with "Burner 4" (if present) as described below:

- 5 - Convert "Burner 4", following points 1 to 16 in section 15.4;

After converting all the Burners, proceed as described below:

- 6 - Check the gas inlet pressure as described in section 15.7;
- 7 - Check the appliance output heat as described in section 15.9;



ATTENTION !!! The measurements must be taken with calibrated instruments that ensure an accurate reading.

- 8.- The gas conversion kit contains self-adhesive labels for the indication of the new gas supply type. The correct label must be selected and applied to the appliance in a prominent location, next to the rating plate where possible. If the appliance has been converted to LPG, "Section B" of the label should be applied; if the appliance has been converted to Natural Gas, "Section A" should be applied.



ATTENTION !!! If you smell gas:

- A - Turn off the gas supply at the gas meter;
- B - Extinguish all naked flames – do not smoke or strike matches;
- C - Do not operate electrical appliances or switches such as a light switch.
- D - Open all doors and windows to ventilate the property.
- E - Call the gas emergency service and follow their directions.

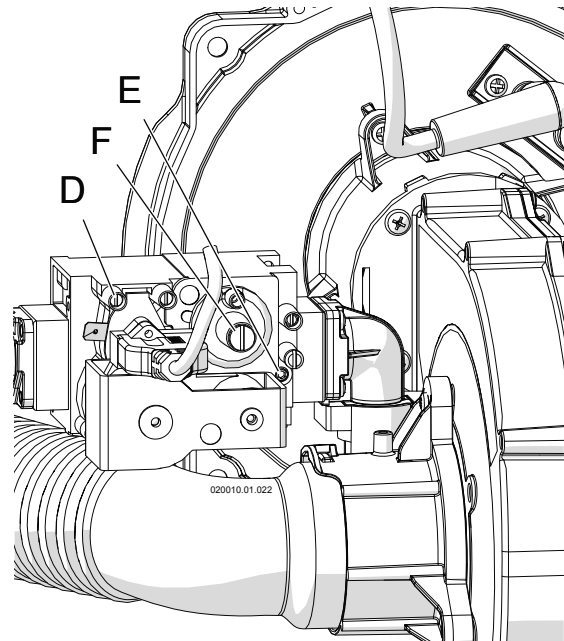

- D - Gas inlet pressure plug.
E - CO₂ adjustment screw.
F - Factory default adjustment screw (do not touch).
Figure 15-6 - Gas valve

15 - COMMISSIONING

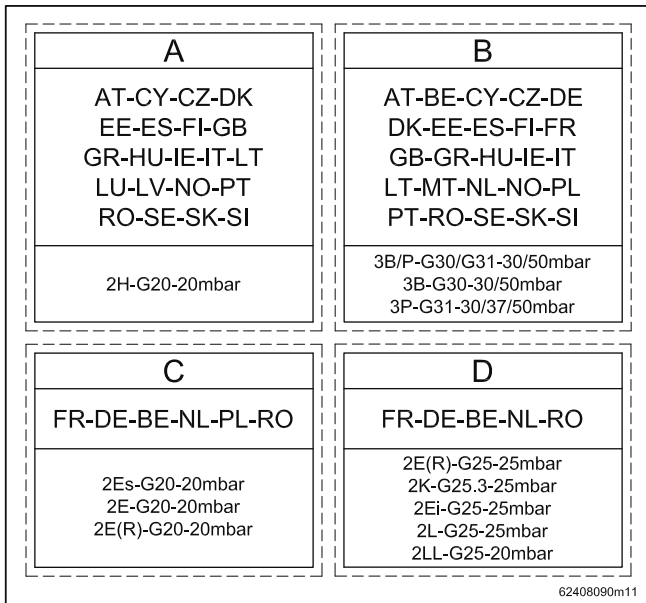

Figure 15-7 - Label bearing the new adjustment status of the appliance





	U.M	70T	140T	210T	280T
Gas supply minimum pressure	mbar	10			
Gas supply maximum pressure	mbar	45			
Nozzle diameter for Natural Gas gas (G20)	mm	9.5	9.5	9.5	9.5
Nozzle diameter for Natural Gas gas (G25)	mm	N/A	N/A	N/A	N/A
Nozzle diameter for LP gas (G31)	mm	6.5	6.5	6.5	6.5
Nozzle diameter for LP gas (G30)	mm	6.0	6.0	6.0	6.0
Natural Gas gas CO ₂ (G20) at maximum output heat	%	from 8.4 to 9.0			
Natural Gas gas CO ₂ (G20) at minimum output heat	%	from 8.3 to 8.7			
Natural Gas gas O ₂ (G20) at maximum output heat	%	from 4.7 to 5.1			
Natural Gas gas O ₂ (G20) at minimum output heat	%	from 5.6 to 6.0			
Natural Gas gas CO (G20) at maximum and minimum output heat	ppm	Less than 150			
Natural Gas gas CO ₂ (G25) at maximum output heat	%	from 8.5 to 9.1			
Natural Gas gas CO ₂ (G25) at minimum output heat	%	from 8.1 to 8.5			
Natural Gas gas O ₂ (G25) at maximum output heat	%	from 4.7 to 5.1			
Natural Gas gas O ₂ (G25) at minimum output heat	%	from 5.6 to 6.0			
Natural Gas gas CO (G25) at maximum and minimum output heat	ppm	Less than 150			
LP gas CO ₂ (G31) at maximum output heat	%	from 9.9 to 10.5			
LP gas CO ₂ (G31) at minimum output heat	%	from 9.6 to 10.0			
LP gas O ₂ (G31) at maximum output heat	%	from 5.2 to 5.6			
LP gas O ₂ (G31) at minimum output heat	%	from 5.8 to 6.2			
LP gas CO (G31) at maximum and minimum output heat	ppm	Less than 250			
LP gas CO ₂ (G30) at maximum output heat	%	from 10.3 to 10.9			
LP gas CO ₂ (G30) at minimum output heat	%	from 9.9 to 10.3			
LP gas O ₂ (G30) at maximum output heat	%	from 4.9 to 5.3			
LP gas O ₂ (G30) at minimum output heat	%	from 5.7 to 6.1			
LP gas CO (G30) at maximum and minimum output heat	ppm	Less than 250			

Figure 15-8 - Settings for the various operating gases



15 - COMMISSIONING

15.6 - Ignition

15.6.1 - Boiler ignition

- 1.- open the gas supply isolation valve;
- 2.- power the appliance and position the main switch to ON (part "T" in figure 16-1);
- 3.- the appliance only switches on when the temperature required by the heating system is higher than the current flow temperature. Adjust the desired temperature for central heating service using the  and  keys. If the external temperature sensor is connected (see section 13.1.4), ensure that the calculated temperature (see section 16.14, parameter 1012, or parameter 1107 for appliances from 115T to 280T) is higher than the current flow temperature and that the measured external temperature (see section 16.14 parameter 1004) is lower than the external temperature that switches off the heating (see section 16.15 parameter 2020);
- 4.- if the appliance is connected to a storage tank (see section 13.2), press the  and  keys to select the desired temperature of the domestic hot water.
- 5.- if the display shows a low water pressure error (see section 16.16.2), bleed the air again.

15.6.2 - Water heater ignition

- 1.- open the gas supply isolation valve;
- 2.- power the appliance and position the main switch to ON (part "T" in figure 16-1);
- 3.- the appliance only switches on when the set temperature is higher than the current supply temperature. Adjust the desired temperature for the supply using the  and  keys.
- 4.- if the display shows a low water flow rate error (see section 16.16.2), bleed the air again.

15.7 - Checking the supply gas pressure and any adjustments

The gas supply pressure must correspond with the value that is given in the table in section 18. To check it, proceed as follows:

- 1.- close the gas supply isolation valve;
- 2.- access the inner components of the appliance by following the procedure in section 17.2;
- 3.- loosen pressure plug "D" (see figure 15-6);
- 4.- connect to a manometer with a resolution of at least 0.1 mbar. For models from 140T to 280T you can use any one of the valves;
- 5.- open the gas supply isolation valve;
- 6.- make sure the pressure does not exceed 45 mbar;
- 7.- position the main switch to ON (part "T" in figure 16-1) and generate a heating demand by pressing the  key until the maximum value. Make sure the room thermostat is being called and the system is ready to dissipate the heat generated;
- 8.- Set parameter 2200 to HI GH (in the 60T and 70T models, use parameter 2010). The burners will now work at maximum output heat for 20 minutes;
- 9.- with the appliance at maximum flow rate, make sure that the gas supply pressure does not drop below 10 mbar. If the pressure is lower, do not attempt to adjust the appliance; you must rectify the supply pipework to ensure the correct supply pressure and gas flow rate.



ATTENTION !!! Do not adjust screw "F" in figure 15-10. It is factory set for proper gas flow rate and supply pressure. Screw "E" in figure 15-10 must only be adjusted as part of either the conversion procedure detailed in section 15.4/15.5 or the adjustment procedure detailed in section 15.8.

After having made sure the gas pressure is correct:

- 1.- Reset parameter 2200 to OFF (in the 70T model use parameter 2010).
- 2.- close the gas supply isolation valve;
- 3.- disconnect the manometer and close pressure plug "D" again;
- 4.- Use a leak detection fluid to check for and gas leaks from pressure plug "D" (figure 15-6);

 Do not force the pressure plug locking screws to avoid damaging the gas valve.



ATTENTION!!! Run the seal test exclusively with a detection fluid. Using naked flames is absolutely prohibited.

15 - COMMISSIONING

15.8 - Checking the CO₂ seal and any adjustments

Table 15-8 shows the correct CO₂ values for an appliance working in normal conditions at an altitude of less than 1000 metres. Values differing from those shown can cause malfunctions. To check and, if necessary, adjust said value a combustion analysis must be done. Proceed as follows:

15.8.1 - Checking the CO₂ seal and any adjustments on 70T model appliances



ATTENTION!!! If, during this procedure, a CO value greater than 1000 ppm is detected, stop the appliance and contact the supplier.

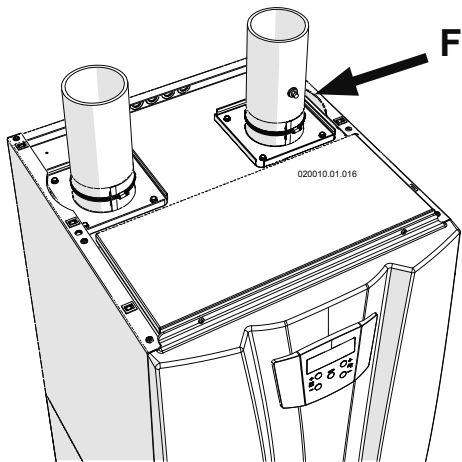

F - Combustion analysis socket

Figure 15-9 - Combustion analysis socket

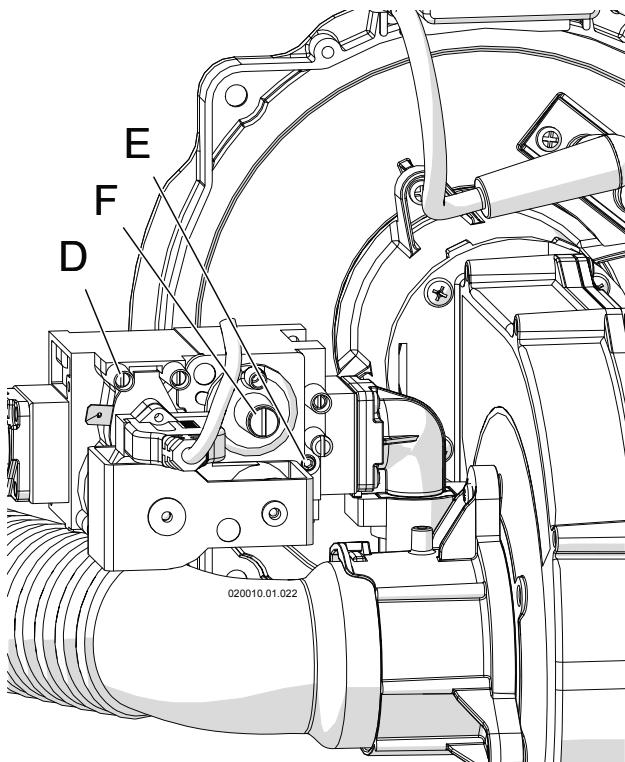

D - Gas inlet pressure plug.

E - CO₂ adjustment screw.

F - Factory default adjustment screw (do not touch).

Figure 15-10 - Gas valve

- 1.- The flue system must contain a purpose provided test point for the analysis of combustion products. The test point should be located as close to the appliance as is possible (see figure 15-9, part "F").
- 2.- Switch on the appliance and open the bridge between terminals "10" and "11";
- 3.- Make sure that the setpoint temperature is higher than the boiler/water heater temperature;
- 4.- Access the installer menu (see section 16.15) and set parameter 2010 to **HIGH**. The appliance will now work for 20 minutes at maximum output heat;
- 5.- Wait for two minutes to allow CO₂ level to stabilise;
- 6.- Insert the combustion analyser sensor into socket "F" shown in figure 15-9;
- 7.- Compare the CO₂ value measured with the value shown in table 15-8. Be sure to read the correct value for the type of gas supplied. If the CO₂ value does not match the one in table 15-8, it must be adjusted via screw "E" in figure 15-10. Use a 2.5 mm hex spanner (turn the screw clockwise to reduce the CO₂ value and anticlockwise to increase it). Make small adjustments, always waiting for the measured CO₂ value to stabilise before continuing, until you reach the desired value.
- 8.- Once the correct CO₂ value as per table 15-8 has been reached, seal the screw with red paint or a similar system to discourage tampering.
- 9.- Set parameter 2010 to **LOW**. The appliance will now work for 20 minutes at minimum output heat.
- 10.- Wait for two minutes to allow the CO₂ level to stabilise;
- 11.- Compare the CO₂ value read with the one in table 15-8. Be sure to read the value for the type of gas being used. The CO₂ value must be within the values shown; if not, stop the appliance and call the supplier.
- 12.- Set parameter 2010 to **OFF** to bring the appliance back to normal operation.
- 13.- Close the combustion analysis hole in figure 15-9 with appropriate plug "F" as per the instructions from the flue system manufacturer.



ATTENTION!!! Once plug "F" is positioned with the appliance at maximum output heat, make sure there are no flue gas leaks.

15 - COMMISSIONING

15.8.2 - Checking the CO₂ seal and any adjustments on appliance models from 140T up to 280T



ATTENTION!!! If, during this procedure, a CO value greater than 1000 ppm is detected, stop the appliance and contact the supplier.

- 1.- The flue system must contain a purpose provided test point for the analysis of combustion products. The test point should be located as close to the appliance as is possible (see figure 15-9, part "F").
- 2.- Put the appliance in stand-by, shutting down all heating demands (remove the room thermostat bridge, if any, or adjust the heating setpoint to off using the  key).
- 3.- Make sure that the required temperature is higher than the boiler/water heater temperature;
- 4.- Access the installer menu (see section 16.15) and set parameter 2201 to HI GH. The MASTER burner will now work for 20 minutes at maximum output heat;
- 5.- Wait for two minutes to allow the CO₂ level to stabilise;
- 6.- Insert the combustion analyser sensor into socket "F" shown in figure 15-9;
- 7.- Compare the CO₂ value measured with the value shown in table 15-8. Be sure to read the correct value for the type of gas supplied. If the CO₂ value does not match the one in table 15-8, it must be adjusted via screw "E" in figure 15-10. Use a 2.5 mm hex spanner (turn the screw clockwise to reduce the CO₂ value and anticlockwise to increase it). Make small adjustments, always waiting for the measured CO₂ value to stabilise before continuing, until you reach the desired value.
- 8.- Once the correct CO₂ value as per table 15-8 has been reached, seal the screw with red paint or a similar system to discourage tampering.
- 9.- Set parameter 2201 to LOU. The MASTER burner will now work for 20 minutes at minimum output heat;
- 10.- Wait for two minutes to allow the CO₂ level to stabilise;
- 11.- Compare the CO₂ value read with the one in table 15-8. Be sure to read the value for the type of gas being used. The CO₂ value must be within the values shown; if not, stop the appliance and call the supplier.



ATTENTION!!! The CO₂ reading, at low fire, could be affected by the natural draught of the chimney (negative pressure inside the chimney). If this is the case, take the CO₂ reading by removing the correspondent flue gas temperature sensor.

- 12.- Set parameter 2201 to OFF.
- 13.- Repeat the operations from point "3" to point "11" on the remaining burners, considering that parameter 2202 corresponds to burner 2, 2203 to burner 3 and 2204 to burner 4.
- 14.- Close the combustion analysis hole in figure 15-9 with appropriate plug "F" as per the instructions from the flue system manufacturer.



ATTENTION!!! Once plug "F" is positioned with the appliance at maximum output heat, make sure there are no flue exhaust leaks, which could cause damage.

15.9 - Checking appliance heat input

The appliance has a factory set air/gas mixture ratio. The gas pressure to the burner is indirectly controlled by the fan. The only way to check the appliance heat input is to directly use a gas meter. Proceed as follows:

1. Switch the appliance on by turning the main switch to ON (part "T" in figure 16-1) and create a heating demand, bring the requested temperature to the maximum value via the  key, making sure that the system is able to dissipate all the heat generated.
2. For the 70T model, set parameter 2010 to HI GH. For all other models, set parameter 2200 to HI GH. The appliance will now work for 20 minutes at maximum input.
3. Measure the gas flow rate at the meter for a period of 2 minutes; multiply the reading by 30 to calculate the flow rate in m³/hour. The value obtained must be compared with the value given in section 18 under "Gas flow rate" and should be within a tolerance of + or -10%.
4. If the flow rate is lower, make sure:
 - a) That there are no obstructions in the air intake and flue exhaust ducts;
 - b) That the lengths of the air intake and flue exhaust ducts correspond to what is described in section 18;
 - c) That the air intake filter (part "11" in figures 3-3, 3-5 and 3-7) is clean;
5. If the gas flow rate is within the tolerance, set parameter 2200 to OFF. In 70T model appliances, set parameter 2010 to OFF to bring the appliance back to normal operation.
6. If the gas flow rate is greater, repeat the procedure in section 15.9.

15.10 - Minimum water flow rate

The appliance has a protection system against low water flow rate. The water flow rate measuring device (part "16" in figure 3-1) continuously measures the flow rate on each exchanger. If the flow rate drops below the "Minimum operating water flow rate" referred to in section 18, the appliance automatically switches off and, if the flow rate does not increase after three minutes, the corresponding error appears on the display.

15.11 - User instructions

Instruct the user on how to properly use the appliance and the entire system in general. In particular:

- ☞ Give the user the use and installation manual and all the documents contained in the packaging.
- ☞ Teach the user about the special measures for the flue exhaust, informing them that they must not be modified.
- ☞ Inform the user of the necessary water pressure control in the system and of the necessary measures to fill and bleed air.
- ☞ Inform the user about properly adjusting temperatures, control units/room thermostats and radiators for energy saving.

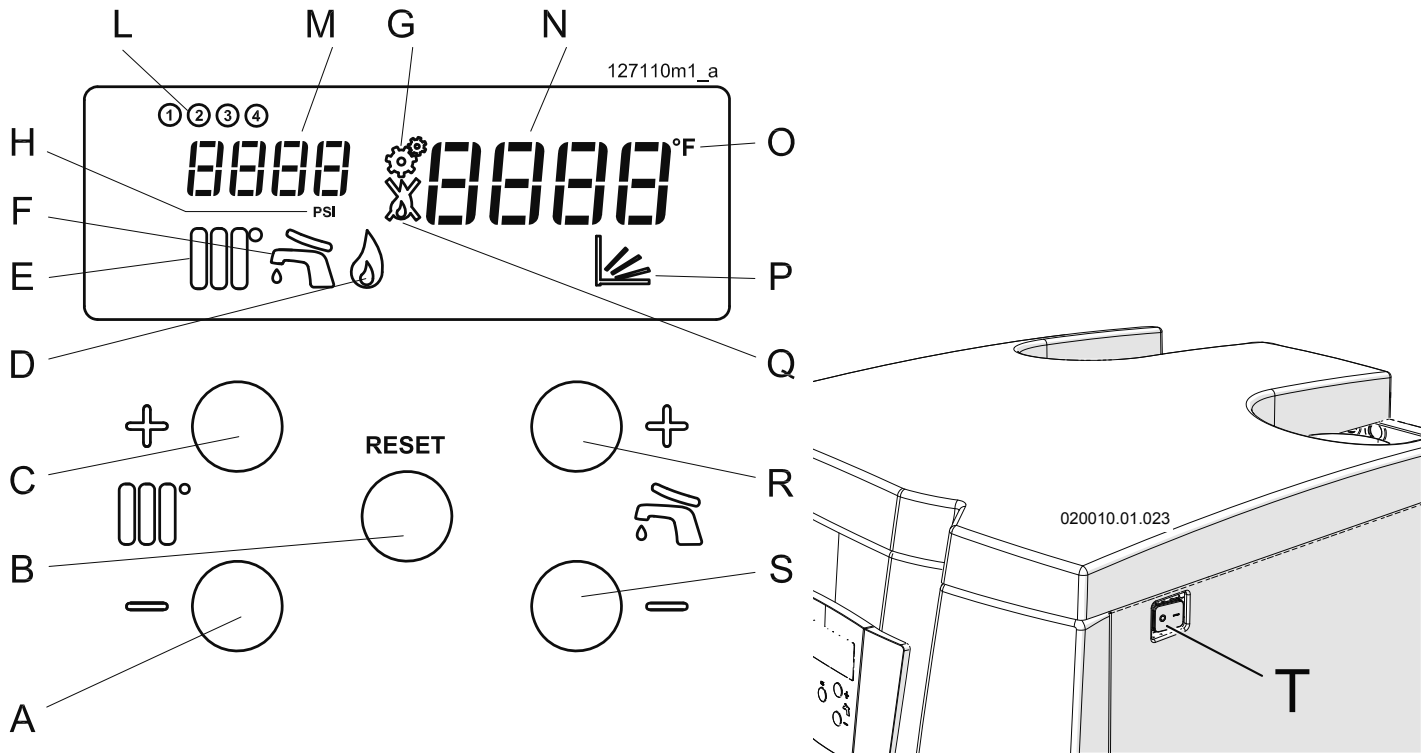

Figure 16-1 - Control panel

FIGURE 16-1 KEY

- A - Key to reduce water temperature
- B - Multifunction key: Key to Reset and access the “user menu” and the “installer menu”
- C - Key to increase water temperature
- D - Burner state
Icon off = burner off
Icon on = burner on
- E - State of heating or direct domestic hot water service
Icon off = Service off
Icon on = Service active but not working
Flashing icon = Service active and working
- F - State of indirect domestic hot water service:
Icon off = Service off
Icon on = Service active but not working
Flashing icon = Service active and working
- G - “Installer menu” access icon
- H - Unit of measurement of the displayed pressure
- L - Burner unit indicator
① = Burner 1 (master)
② = Burner 2
③ = Burner 3
④ = Burner 4
- M - Water pressure or indicator of the different parameters in the various menus
- N - Heating or domestic hot water temperature or indicator of the values assumed by the various parameters
- O - Unit of measurement of the displayed temperature
- P - Heating service adjusted by the external temperature sensor
- R - Key to increase the temperature of the indirect domestic hot water storage tank and to change parameter values
- S - Key to reduce the temperature of the indirect domestic hot water storage tank and to change parameter values
- T - on/off switch

16.1 - Checking water pressure

16.1.1 - Checking boiler water pressure

If the pressure inside the heating circuit drops below 0.5

bar, display “N” in figure 16-1 displays **Err 59** to show that correct pressure needs to be restored. To do so, proceed as follows:

- 1.- open the filling device, provided by the installer upstream of the appliance to fill the system;
- 2.- check the pressure on view “M” in figure 16-1; it must reach a pressure of 1.5 bar (the **Err 59** warning must disappear);
- 3.- close the filling device provided by the installer upstream of the appliance.



ATTENTION !!! During normal operation, the filling device provided by the installer upstream of the appliance to fill the system must always remain in the closed position.

If, over time, the pressure goes down, restore the correct value. In the first month of operation, it might be necessary to repeat this operation several times to remove any air bubbles in the system.

16.1.2 - Checking water heater system pressure

If the pressure in the circuit drops to below the minimum pressure value, the appliance automatically switches off

and display “N” in figure 16-1 displays **Err 59** (see section 16.16.2) to show that correct pressure needs be restored. As the water heater is installed in an open circuit, you must check the mains supply pressure or the adjustment of any pressure reducers installed upstream.

When the value is reestablished, **Err 59** disappears from the display.

16.2- General information

The appliance leaves the factory set with standard parameters. However, you can consult or make a series of changes to the parameters through the "user menu" (section 16.14) and the "installer menu" (section 16.15). During operation, the display shows the appliance operating status in addition to other information as described in section 16.16 (Diagnostics).

16.3 - Display

During normal operation, you can consult further parameters through the "User menu" (see section 16.14) that are helpful in understanding appliance operation and check the latest blocks or errors that have occurred. After 5 minutes of normal operation, the display switches off completely to save energy. Simply press any key to switch it back on. In the event of any anomaly, the display switches back on automatically. This function can be modified by following section 16.13 (Energy saving).

16.4 - Ignition and shutdown procedure

To switch ON the appliance, proceed as follows:

- 1.- open the gas isolation valve;
- 2.- power the appliance;
- 3.- If the display shows **Err 65**, it means that phase and neutral polarity were not respected (call a competent person to check the wiring without attempting to fix it yourself).
- 4.- adjust the domestic hot water temperature, if any, and the heating temperature respectively as per sections 16.5, 16.6 and 16.7.

The command and control equipment will ignite the burner. If ignition is unsuccessful, the appliance automatically attempts ignition five times, after which, if it continues not to switch on, it locks up and the display will show **LOC 1** along with the  icon and the corresponding flashing ① ② ③ ④ burner icon. Press the RESET key to restore normal operating conditions. The appliance will automatically attempt another ignition.





ATTENTION!!! If the appliance frequently stops because it locks up, contact a competent person to investigate and reset normal operating conditions.

Once started properly, the appliance will continue to work for the service requested.

To switch OFF the appliance, proceed as follows:

- 1.- Use switch "T" in figure 16-1 to cut power;
- 2.- close the gas cock;

16.5 - Direct water heater temperature adjustment

To adjust the temperature, use the  or  keys



(see figure 16-1). When the keys are pressed, the display, part "N" in figure 16-1, shows the requested temperature. The instantaneous domestic hot water temperature adjustment ranges goes from 20°C to 80°C.



ATTENTION!!! The water heater should be adjusted to ensure that water is stored at a temperature greater than 60°C and a temperature of 50°C is achieved at all outlets within 1 minute. Excessive temperatures significantly increase the possibility of scalding with children and those with a sensory or mobility loss being at the greatest risk. Where the possibility of scalding

has been identified, appropriate measures such as thermostatic mixing valves should be considered.

16.6 - Indirect domestic hot water adjustment



If the appliance is installed for double service (heating and domestic hot water production), adjust the domestic hot water temperature using the  and  keys (see figure

16-1). When the keys are pressed, the display, part "N" in figure 16-1, shows the requested D.H.W. temperature. The temperature adjustment ranges goes from 40°C to 60°C.





ATTENTION!!! The water heater should be adjusted to ensure that water is stored at a temperature greater than 60°C and a temperature of 50°C is achieved at all outlets within 1 minute. Excessive temperatures significantly increase the possibility of scalding with children and those with a sensory or mobility loss being at the greatest risk. Where the possibility of scalding has been identified, appropriate measures such as thermostatic mixing valves should be considered.

16.7 - Boiler heating adjustment

Adjust the appliance heating temperature using the  or  keys (see figure 16-1). The room thermostat switches on the circulation pump in order to meet heating requests.

16.8 - Thermostat type heating adjustment

The boiler is by default set with parameter 2003 at 0, therefore, the boiler supplies the heating system with hot water at a temperature adjusted using the  and  keys. Any room thermostats enable or disable the heating function to adjust the temperature of the rooms. To take full advantage of boiler performance, it is advisable to adjust the heating temperature to a value that is just enough to obtain the desired room temperature. As climatic conditions grow colder, the heating temperature should be progressively increased. As the climatic conditions grow warmer, the heating temperature should be reduced.

16.9 - Temperature compensated operation

Adjust parameter 2003 to 1 using the "Installer menu". The heating supply temperature is related to the measured external temperature according to the algorithm referred to in figure 16-2. To adapt the calculation line to the various rooms/climatic conditions, all the adjustment parameters must be set according to the following sections.

16.9.1 - Climatic adjustment: setting the parameters

Through the "Installer menu" (see section 16.15), set:

- 2020 = "Compensated heating switch-off temperature", adjustable between 0 and 35°C. When the measured external temperature reaches the value set in this parameter, the heating switches off automatically. When the measured external temperature drops below that value again, the heating automatically switches back on. The recommended start value is 22°C.
- 2021 = "Compensated design temperature (winter)", adjustable between -20 and 5°C. This is the design temperature used to define the output heat the system requires. The recommended start value for a typical building is -5°C;
- 2022 = "Supply temperature corresponding to the compensated design temperature (winter)", adjustable between 0 and 80°C. The supply temperature setpoint is adjusted to the value set in this parameter when the external temperature corresponds with the number set in parameter 2021. The recommended start values are: 40°C for low temperature systems (floor heating); 70°C for high temperature systems (radiators);
- 2023 = "Limiting external temperature", adjustable between 0 and 30°C. This is the external temperature at which you wish the heating to reach its minimum supply temperature. The recommended start value is 18°C.
- 2024 = "Supply temperature corresponding to limiting external temperature", adjustable between 0 and 40°C. The supply temperature is adjusted to the value set in this parameter when the external temperature corresponds with the number set in parameter 2023. The recommended start values are: 30°C for low temperature systems (floor heating); 42°C for high temperature systems (radiators);
- In addition, you can set the minimum and maximum heating temperature, using respective parameters 3016 and 3015 in section 19.

If, for some reason, the heating service does not correspond to the load, using parameters 2022 (Supply temperature corresponding to the compensated design temperature (winter)), you can raise or lower the calculated temperature and match the desired room temperature.

16.9.2 - Temperature compensated operation: switching the heating system on and off

The temperature compensation system is completely automatic, switching off the heating system at the end of the season and reignition at the beginning of the season, via parameter 2020. When the external temperature exceeds

the value set in this parameter, the heating switches off automatically. When the external temperature drops below the value set in this parameter, the heating switches back on automatically.

16.10 - Timing of the various functions

To protect the lifespan of the appliance, improve the comfort generated and increase energy savings, timers were put in during operation. These timers are:

- Pump post-circulation: every time the room thermostat detects the end of a heating service, the pump continues to work for 4 minutes;
- Pump anti-lock: every 24 hours, the heating pump and the domestic hot water pump (if present) are forced;
- Ignition delay: In all operating modes, every time the burner switches off, it waits 3 minutes before switching back on.

16.11 - Pump anti-locking

During the summertime, the circulator switches on once every 24 hours for 15 seconds to prevent any limescale build-ups from clogging it. At the same time, the diverter valve and the hot water tank pump (if present) are activated for the same reason.

16.12 - Antifreeze protection



ATTENTION !!!

In order for the antifreeze protection to be effective, the appliance must be left with the power and gas supply on and the two services (domestic water and heating)

in the OFF position.



ATTENTION !!!

The antifreeze protection provided by the appliance cannot ensure antifreeze protection for the heating system, the domestic water system, nor for the building being served or parts of it.

Once the boiler temperature of 10°C is reached, the heating pump automatically switches on. If the temperature drops further below 5°C, the burner also switches on in order to protect the appliance from the effects of frost.

If you do not use the appliance for a long period of time (over a year), we recommend draining it, following the procedure in section 17.10.

16.13 - Energy Saving

To reduce display energy consumption (figure 16-1), it switches off automatically 5 minutes after the last operation done. You

can disable this function or edit the time via parameter 2100 in the "installer menu" (section 16.15). If you set the parameter to 0, the display will remain on constantly.

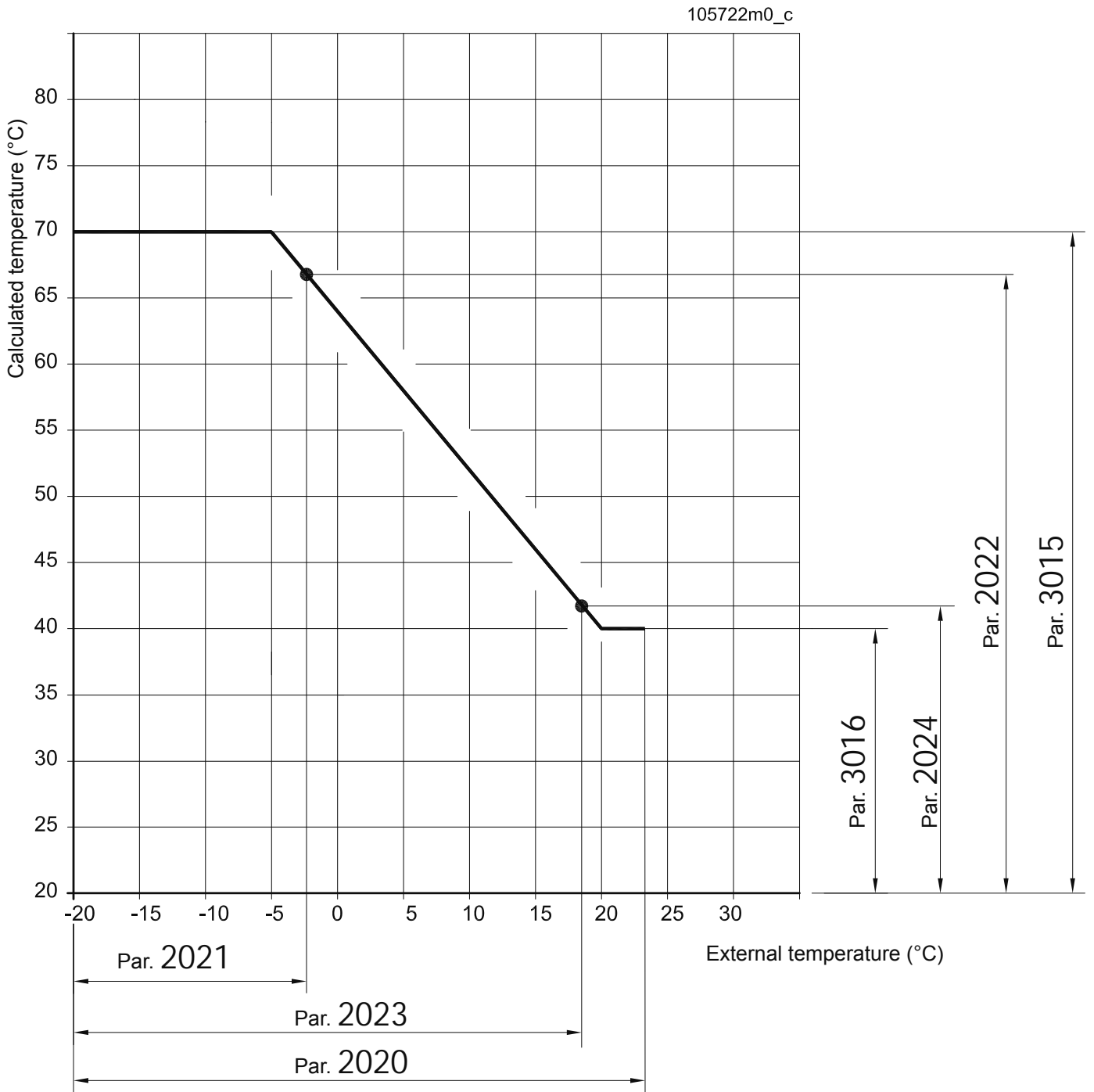



- Par. 2020 = Compensated heating switch-off temperature
- Par. 2021 = Compensated design temperature (winter)
- Par. 2022 = Supply temperature corresponding to the compensated design temperature (winter)
- Par. 2023 = Limiting external temperature
- Par. 2024 = Supply temperature corresponding to limiting external temperature
- Par. 3016 = Minimum supply temperature
- Par. 3015 = Maximum supply temperature

Figure 16-2 - Temperature compensated operation graphic

16 - USE

16.14 - "User menu"

Pressing the RESET key for 2 seconds accesses the "user menu". Display "M" in figure 16-1 begins to show parameter 1001 to tell the user that the mode has changed.

Using the  + and  = keys, you can scroll through the parameters in the menu.

To exit the menu, simply press the RESET key again for 2 seconds.

If no keys are pressed for more than 60 seconds, it automatically exits the menu.

For models from 140T to 280T, all the parameters indicated as "Burner 1" refer to the appliance Master Burner. To display the same parameters for the other burners, you must connect the display to the burner in question as described in section 17.8. The following parameters can be accessed in this menu:

Parameter	Parameter description	U.M.
1001	Burner 1 - Water supply temperature	°C
1002	Hot water storage tank temperature (if present)	°C
1004	External temperature (visible when an external temperature sensor is installed)	°C
1006	Burner 1 - Flue gas temperature	°C
1007	Burner 1 - Return temperature	°C
1008	Burner 1 - Ionisation current	uA
1009	Burner 1 - Main circuit pump and motorised valve status	ON/OFF
1010	Heating circuit pump status	ON/OFF
1011	Domestic hot water circuit pump status	ON/OFF
1012	Calculated heating setpoint (with external temperature sensor enabled) (only for 70T models. See Parameter 1107 for the other models)	°C
1040	Burner 1 - Current fan rotation speed	rpm
1041	Burner 1 - Fan rotation speed at ignition	rpm
1042	Burner 1 - Fan rotation speed at minimum output heat	rpm
1043	Burner 1 - Fan rotation speed at maximum output heat	rpm
1051	Burner 1 - Last recorded lock-up (Loc) (see section 16.16.1) (255 means no block)	/
1052	Burner 1 - Last recorded error (Err) (see section 16.16.2) (255 means no error)	/
1053	Burner 1 - Number of times the burner lost its flame	No.
1055	Burner 1 - Number of failed burner ignitions	No.
1056	Burner 1 - Number of hours worked	h x 10
1057	Burner 1 - Number of hours worked in domestic water with indirect hot water storage tank	h x 10
1059	* interval of time between the last two errors (Err)	1 : value in minutes; 2 : value in hours;
1060	* interval of time between the last two lock-ups (Loc)	3 : value in days; 4 : value in weeks;
1062	Burner 1 - Water flow rate	l/min
1101	Multi-burner: Number of burners on	No.
1102	Multi-burner: Manifold temperature	°C
1103	Multi-burner: Number of burners locked (Loc)	No.
1104	Multi-burner: Number of burners in Error (Err)	No.
1106	Multi-burner: Appliance in emergency	Yes/No
1107	Multi-burner: Calculated heating setpoint (only 140T, 210T and 280T models) (see Parameter 1012 for the 70T models)	°C
1120	Multi-burner: Burner 1 modulation level	%
1121	Multi-burner: Burner 2 modulation level	%
1122	Multi-burner: Burner 3 modulation level	%
1123	Multi-burner: Burner 4 modulation level	%

* How to read the values of parameters 1059 and 1060:

i.e.: If it shows 1:29, it means 29 minutes;

i.e.: If it shows 2:12, it means 12 hours;

i.e.: If it shows 3:15, it means 15 days;

i.e.: If it shows 4:26, it means 26 weeks.

16.15 - "Installer menu"



ATTENTION !!! Editing these parameters could cause the appliance and, therefore, the system to malfunction. For this reason, only technicians with in-depth knowledge and awareness of the appliance can edit them.

The appliance command and control board makes this parameter menu available to technicians for operating and appliance adaptation to the individual system characteristics.

To access the "installer menu", proceed as follows:

1.- hold down the RESET and + keys at the same time for 5 seconds until parameter 2001 is displayed.

The symbol appears at the centre of the display to show access to the "installer menu".

- 2.- you can use the + and - keys to scroll through the parameters in the menu;
- 3.- once the parameter you are interested in is displayed, you can edit it as follows:
- a.- press the RESET key to access the parameter (display "N" in figure 16-1 will begin flashing);

b.- edit the parameter value using the + and

- keys;

c.- press the RESET key to confirm the edited data and go back to the list of parameters;

4.- To exit the "installer menu", hold down the RESET key for 5 seconds until the symbol disappears from the display.

If no keys are pressed for more than 60 seconds, it automatically exits the menu. Any data changes that are not confirmed with the RESET key will be lost.

For 140T to 280T models, the parameters indicated as "Burner 1" refer only to Burner 1 (Master). To display or edit the same parameters for the other burners, you must connect the display to the burner in question as described in section 17.8.



ATTENTION !!! In order to facilitate any command and control board replacements, it is essential to make a note of any changes made to the parameters in the "customised values" column in the following table.

The following parameters can be edited or consulted in this menu:

Parameter	Parameter description	U.M.	Setting field	BOILER default value	WATER HEATER default value	Cus-tomised values
2001	Minimum output heat level	%	From 1 to 50	1	1	
2002	Maximum output heat level	%	From 1 to 100	100	100	
2003	Heating operating mode	nn	0 = With room thermostat 1 = External temperature sensor with TA 2 = External temperature sensor closing TA reduce of 2027 3 = Permanent heating closing TA reduce of 2027 4 = With 0-10 Volt input 5 = N/A	00	00	
2004	Stand-by time after differential maximum	sec	From 10 to 30	30	30	
2005	Heating pump post-circulation	sec	From 10 to 260	240	240	
2010	Burner 1 - Burner forcing	/	Off = No forcing Low = Minimum output heat Ign = Ignition output heat High = Maximum output heat	OFF	OFF	
2011	Main circuit pump and motorised 2-way valve forcing (Burner 1)	/	On or OFF	OFF	OFF	
2012	Heating circuit pump forcing	/	On or OFF	OFF	OFF	
2013	Domestic hot water circuit pump forcing	/	On or OFF	OFF	OFF	
2014	Icon test on the display. All the icons on the display come on by pressing the RESET key. The display goes back to normal function by pressing the RESET key again.	/	/	/	/	
2020	Temperature compensated operation: compensated heating switch-off temperature	°C	From 0 to 35	22	N/A	
2021	Temperature compensated operation: compensated design temperature (winter)	°C	From -20 to 5	-5	N/A	



16 - USE

2022	Temperature compensated operation: supply temperature corresponding to the compensated design temperature (winter)	°C	From 0 to 80	80	N/A	
2023	Temperature compensated operation: limiting external design temperature	°C	From 0 to 30	20	N/A	
2024	Temperature compensated operation: supply temperature corresponding to the limiting external temperature	°C	From 0 to 40	40	N/A	
2027	Night-time Reduction	°C	From 0 to 50	10	N/A	
2040	N/A	N/A	N/A	N/A	N/A	
2041	N/A	N/A	N/A	N/A	N/A	
2042	Burner 1 - Protection against frequent ignitions: time	sec	From 10 to 900	180	180	
2043	Burner 1 - Protection against frequent ignitions: temperature differential	°C	From 0 to 20	16	5	
2062	Domestic water pump post-circulation	sec	From 10 to 255	240	240	
2063	Maximum D.H.W. priority time	min	From 1 to 60	30	N/A	/
2067	D.H.W. production priority	/	0 = The priority lasts the amount of time set in parameter 2063; 1 = OFF, domestic water does not have priority over heating; 2 = ON, domestic water always has priority over heating;	2	N/A	
2100	Display energy saving	min	From 0 to 30 = delay to switch-off in minutes.	5	5	
2101	Multi-burner: emergency mode	/	Yes or No	Yes	Yes	
2102	Multi-burner: Emergency temperature adjustment	°C	from 20 to 65	45	45	
2103	Multi-burner: ignition delay	sec	from 1 to 900	180	15	
2104	Multi-burner: switch-off delay	sec	from 1 to 900	180	15	
2105	Multi-burner: burner ignition temp. delta	°C	from 0 to 20	5	5	
2106	Multi-burner: burner switch-off temp. delta	°C	from 0 to 20	5	5	
2107	Multi burner: maximum temp. increase with respect to calculated temp.	°C	from 0 to 20	10	4	
2108	Multi burner: maximum temp. decrease with respect to calculated temp.	°C	from 0 to 20	20	4	
2109	Multi-burner: Subsequent burner ignition	%	from 1 to 100	70	70	
2110	Multi-burner: Subsequent burner switch-off	%	from 1 to 100	10	10	
2111	Multi-burner: Burner rotation	dd	from 0 to 9	6	6	
2113	Multi-burner: Modulation start delay	min	from 0 to 60	5	0	
2114	Burner 1: Main circuit pump shutdown time	sec	from 0 to 255	240	240	
2200	Forcing: All the Burners together.	\	Off, Low, Ign, High	OFF	OFF	
2201	Forcing: Burner 1 (Master).	\	Off, Low, Ign, High	OFF	OFF	
2202	Forcing: Burner 2.	\	Off, Low, Ign, High	OFF	OFF	
2203	Forcing: Burner 3.	\	Off, Low, Ign, High	OFF	OFF	
2204	Forcing: Burner 4.	\	Off, Low, Ign, High	OFF	OFF	

N/A = Not Applicable

16.16 - Diagnostics

During normal appliance operation, display "N" in figure 16-1 continuously shows the appliance work status via the following indications:

Parameter	Parameter description	Display on display "N" in figure 16-1
AFro	Antifreeze function active	Boiler temperature (°C)
	Domestic hot water with indirect storage tank operating status	Domestic hot water temperature (°C)
	Heating or direct domestic hot water operating status	Supply temperature (°C)

16.16.1 - Diagnostics: "Loc" lock

Lock-up	Lock-up description	Checks	Solutions
Loc 1	No flame detected after 5 consecutive ignition attempts.	A - Supply gas pressure (see section 15.7); B - Sparks on the ignition electrodes (see section 17.5); C - Correct gas pressure and CO ₂ value (see sections 15.7 and 15.8); D - 230Vac power supply to the gas valve; E - 0.88 Kohm and 6.59 Kohm electrical resistance of the two gas valve coils F - If the burner ignites and goes out at the end of the ignition attempt, make sure: that the ionisation current value is greater than 4 (follow the procedure in section 17.12)	A - If the pressure is incorrect, it must be restored upstream of the appliance; B - Check and correct electrode positions (section 17.5); C - Remove any obstructions in the air intake and flue exhaust ducts; D - If the supply current to the gas valve is not 230 Vac, replace the control board; E - If the resistance does not match, replace the gas valve; F - If the ionisation current does not match, check the CO ₂ as per section 15.8. Make sure the detection electrode is in good condition and, if necessary, replace it. Make sure the detection electrode connection cable is in good condition and, if necessary, replace it.
Loc 2 (*)	Gas valve not supplied during ignition attempts	A - Check whether the supply safety thermostat has tripped; B - Check whether the flue exhaust safety fuse has tripped;	⚠ATTENTION !!! If the flue exhaust temperature safety fuse trips, you must contact the appliance supplier to avoid serious damage to the exchanger.
Loc 3	Gas valve loses power during operation	Make sure the electrical connections between the gas valve and control board are in good condition;	A - If the electrical connections are interrupted, restore them; B - If the connections are in good condition, try replacing the gas valve or the control board;
Loc 4	Gas valve relay does not close	Make sure the electrical connections between the gas valve and control board are in good condition;	A - If the electrical connections are interrupted, restore them; B - If the connections are in good condition, try replacing the gas valve or the control board;
Loc 5 (*)	Gas valve circuit	A - Check whether the supply safety thermostat has tripped; B - Check whether the flue exhaust safety fuse has tripped;	⚠ATTENTION !!! If the flue exhaust temperature safety fuse trips, you must contact the appliance supplier to avoid serious damage to the exchanger.
Loc 6	Safety relay opening error		Replace the command and control board
Loc 7	Safety relay closing error		Replace the command and control board
Loc 11	Locking error exceeding 20 hours	Press the RESET key to see the type of error (Err) and proceed accordingly;	
Loc 12	Fan error	A - Check the 230Vac power supply to the fan; B - Check the PWM connection to the fan;	A - If the power supply does not match, replace the control board; B - If there is no fan PWM dialogue, replace the control board; C - Try replacing the fan;
Loc 13	Software error inside command board		Replace the command and control board
Loc 14	Software error inside command board		Replace the command and control board
Loc 15	Software error inside command board		Replace the command and control board
Loc 16	Software error inside command board		Replace the command and control board
Loc 17	Software error inside command board		Replace the command and control board
Loc 18	Software error inside command board		Replace the command and control board
Loc 19	Software error inside command board		Replace the command and control board

16 - USE

Loc 20	Flame lost three times	<p>Make sure: that the ionisation current is at a value higher than 4 (follow the procedure in section 17.12)</p> <p>Make sure: that the flue exhaust is appropriately protected from obstructions caused by gusts of wind</p>	<p>If the ionisation current is not over 4, you must check the CO2 (follow section 15.8) and restore the proper value. Check the ionisation glow plug and, if necessary, replace it. Make sure the ionisation current electrical circuit cables are intact.</p> <p>If the flue exhaust is positioned on a vertical wall, it must be protected by a windproof grid. If the flue exhaust is positioned on the roof, make sure it is not in a reflux area and that the windproof chimney, if any, is actually efficient.</p>
Loc 21	Software error inside command board		Replace the command and control board
Loc 22	Software error inside command board		Replace the command and control board
Loc 23	Software error inside command board		Replace the command and control board
Loc 24	Software error inside command board		Replace the command and control board
Loc 25 (*)	Gas valve circuit	<p>A - Check whether the heating supply safety thermostat has tripped;</p> <p>B - Check whether the flue exhaust temperature safety fuse has tripped;</p>	<p>⚠ATTENTION !!! If the flue exhaust temperature safety fuse trips, you must contact the appliance manufacturer to avoid serious damage to the exchanger.</p>
Loc 26	Software error inside command board		Replace the command and control board
Loc 27	Flame with gas valve closed		Replace the gas valve
Loc 28	Flame with gas valve closed		Replace the gas valve
Loc 29 (*)	Interlock input	<p>A - Check LWCO connection;</p> <p>B - Check flue blocked pressure switch;</p>	<p>A - If LWCO intervenes, try to reset it.</p> <p>B - Check if flue gas line is free from any blockage</p>
Loc 30	Software error inside command board		Replace the command and control board
Loc 31	Flame lost three times	<p>A - Check the detection electrode;</p> <p>B - Make sure that the flue exhaust is appropriately protected from obstructions caused by gusts of wind.</p> <p>C - Check for any flue exhaust recirculation</p>	<p>A - Try replacing the detection electrode.</p> <p>B - Check for and, if necessary, remove any obstructions from the air intake and flue exhaust ducts;</p> <p>C - Find the cause of the flue exhaust recirculation</p>
Loc 32	Software error inside command board		Replace the command and control board
Loc 33	Software error inside command board		Replace the command and control board
Loc 34	Software error inside command board		Replace the command and control board
Loc 35	Software error inside command board		Replace the command and control board
Loc 36	Software error inside command board		Replace the command and control board
Loc 37	Software error inside command board		Replace the command and control board
Loc 38	The flue exhaust sensor temperature does not rise when the burner ignites	<p>a-make sure the flue gas sensor meets the requirement in section 17.14.</p> <p>b - Make sure that the flue gas sensor (parameter 1006) increases the temperature when the burner ignites.</p>	<p>a-If the flue gas sensor does not meet section 17.14, it must be replaced.</p> <p>b - If the temperature does not rise, replace the flue gas temperature sensor or the command and control board.</p>

* This error stops all the burners

16.16.2 - Diagnostics: “E” errors

Error	Error description	Checks	Solutions
Err 0	A sensor is out of the measurement range	Make sure all the temperature sensors are in a plausible measurement range	Replace any sensors that are not in the proper temperature range or replace the main board
Err 45	Software error inside command board		Replace the command and control board
Err 46	Software error inside command board		Replace the command and control board
Err 47	Software error inside command board		Replace the command and control board
Err 48	Software error inside command board		Replace the command and control board
Err 49	Software error inside command board		Replace the command and control board
Err 50	Software error inside command board		Replace the command and control board
Err 51	Software error inside command board		Replace the command and control board
Err 52	Software error inside command board		Replace the command and control board
Err 53	Software error inside command board		Replace the command and control board
Err 54	Flame detected at a time in which it should not be		Replace the command and control board
Err 55	Low water pressure error	Check the state of the pressure measuring device	Replace the pressure measuring device.
Err 56	Low water pressure error	Check the state of the pressure measuring device	Replace the pressure measuring device.
Err 57	Low water pressure error	Check the state of the pressure measuring device	Replace the pressure measuring device.
Err 58	Low water pressure error	Check the state of the pressure measuring device	Replace the pressure measuring device.
Err 59 (*)	Low water pressure error	Check the system pressure and, if necessary, increase it.	If the detected pressure is greater than parameter 3022, replace the pressure measuring device.
Err 60	Flue exhaust temperature high error	A - Check the combustion output of the burner in error; the output must be higher than 97% (referring to the PCI). B - Make sure the flue exhaust temperature sensor resistance matches with the graphic in section 17.14.	A - If the output is lower than 97%, try cleaning the flue gas side and the water side of the heat exchanger. B - If the sensor does not match, it must be replaced.
Err 61	Return temperature greater than supply temperature	Make sure the return sensor electrical resistance matches with the graphic in section 17.14.	If the sensor does not match, it must be replaced.
Err 62 (*)	Condensate level sensor error	A - Make sure the condensate exhaust duct is not obstructed; B - Check the state of the condensate neutraliser;	A - Free the condensate exhaust duct of any obstructions; B - Replace the product contained in the condensate neutraliser;
Err 64	Frequency signal error or WD communication error	A - Check the signal frequency. It must be between 45 and 55 Hz. B - Make sure the grounding and the neutral are at 0 volt	A - If the frequency does not fall within the values, ask the electrical service provider. Otherwise, try replacing the control board. B - If the neutral is not at zero, restore the correct electrical power supply. If the neutral is at 0 volt, try replacing the board.
Err 65	Polarity inverted between phase and neutral.	Check proper polarity between phase and neutral.	Invert the polarity between phase and neutral.

16 - USE

Err 66	Frequency signal error	A - Check the signal frequency. It must be between 45 and 55 Hz. B - Make sure the grounding and the neutral are at 0 volt	A - If the frequency does not fall within the values, ask the electrical service provider. Otherwise, try replacing the control board. B - If the neutral is not at zero, restore the correct electrical power supply. If the neutral is at 0 volt, try replacing the board.
Err 67	Grounding error	Make sure the appliance is correctly grounded.	Restore correct appliance grounding.
Err 68	Watchdog communication error		Replace the command and control board
Err 72	Supply sensor open	Make sure the sensor electrical resistance matches with the graphic in section 17.14.	If the sensor does not match, it must be replaced.
Err 73	Return sensor open	Make sure the sensor electrical resistance matches with the graphic in section 17.14.	If the sensor does not match, it must be replaced.
Err 76	D.H.W. sensor open	Make sure the sensor electrical resistance matches with the graphic in section 17.14.	If the sensor does not match, it must be replaced.
Err 80	Supply sensor in short circuit	Make sure the sensor electrical resistance matches with the graphic in section 17.14.	If the sensor does not match, it must be replaced.
Err 81	Return sensor in short circuit	Make sure the sensor electrical resistance matches with the graphic in section 17.14.	If the sensor does not match, it must be replaced.
Err 84	D.H.W. sensor in short circuit	Make sure the sensor electrical resistance matches with the graphic in section 17.14.	If the sensor does not match, it must be replaced.
Err 86	Flue exhaust sensor in short circuit	Make sure the sensor electrical resistance matches with the graphic in section 17.14.	If the sensor does not match, it must be replaced.
Err 87	RESET key error	RESET key pressed too many times in 60 seconds	
Err 93	Appliance selection error	Check the 3000 parameters list (section 19)	
Err 107	Software error inside command board		Replace the command and control board
Err 108	Software error inside command board		Replace the command and control board
Err 109	Error burner 2,3 or 4	When burner 1 (MASTER) goes in a general error, it stops all others burner and generates an Err 109	Resolve the error to burner 1 (MASTER)
Err 110	Flapper valve not open error		A - Check for and, if necessary, remove any obstructions in the air intake and flue exhaust ducts; B - Check the flapper valve (part 31 fig 3-2)
Err 111	Flapper valve not closed error		Check the flapper valve (part 31 fig 3-2)
Err 112	Flapper inlet error	Make sure parameter 3005 is set to 0 or 4	If parameter 3005 is 0 or 4, replace the command board.
Err 113	Software error inside command board		Replace the command and control board
Err 114	Water flow rate too low	Check the flow rate to the burner (parameter 1062), it must be greater than parameter 3035.	A - Increase the water flow rate to the system; B - Check for and, if necessary, remove any obstructions from the system.
Err 115	Master board error		Reset via parameter 3013.
Err 116 (*)	Multiple burner communication failure	A - BUS communication interrupted B - A burner is not powered	A - Check the BUS connection. B - Restore power to all the burners
NO CONN	Microprocessor locked up	A - Make sure that the pressure measuring device wires are not short circuiting B - Make sure that the supply measuring device wires are not short circuiting C - Check display wires are connected to the burner 1 (MASTER)	A - If it is not short circuiting, replace the pressure measuring device (or disconnect it via menu 3000). B - If it is not short circuiting, replace the supply measuring device (or disconnect it via menu 3000). C - If the display is not connected to burner 1 (MASTER) shows "NO CONN". D - If it is none of the above cases, replace the control board and/or the display.

* This error stops all the burners

17 - MAINTENANCE

17.1 - General warnings

This section must be brought to the installer's attention, highlighting the tasks to maintain proper system operation; The installer is also obligated to inform the user that failure to take care of and service this appliance could cause malfunctions.

It is advisable to follow scheduled annual system maintenance for the following reasons:

- to keep appliance efficiency high, thereby saving fuel;
- to keep a high level of working safety;
- to keep the exhaust emission levels low;



ATTENTION!!! The appliance must only be serviced by a competent person.



ATTENTION !!! During maintenance operation, to ensure the smooth operation of the appliance, it is necessary to check the good condition, the correct operation and the possible presence of water leakage of all the air purge valves present in the appliance.



ATTENTION!!! Before performing any maintenance operations, disconnect the appliance from the electrical supply using the specific isolator, located nearby.



ATTENTION!!! Close the gas supply isolation valve before performing any maintenance operations

The box below shows the operations to do at every maintenance session.

MAINTENANCE PROTOCOL

- Make sure there are no gas leaks
(Follow section 17.1.1.);
- Make sure the air intake and flue exhaust systems are in good condition
(Follow section 17.1.2);
- Make sure the system water pressure is correct
(Follow section 17.1.3.);
- Check the ignition and detection electrodes
(Follow section 17.1.4.);
- Clean the burner and the flue gas side main exchanger and make sure the heat insulators are in good condition
(Follow section 17.4.);
- Clean the air intake filter
(Follow section 17.6.);
- Clean the condensate drain system
(Follow section 17.7.);
- Check appliance performance
(Follow section 17.13.);

17.1.1 - Gas leak check

- 1.- Make sure there are no gas leaks in the system following the approved tightness testing procedures, conforming to the national standards in force.



ATTENTION!!! Do not carry out these checks in the presence of naked flames.

17.1.2 - Making sure the air intake and flue exhaust ducts are in good conditions

1. - Check whether the air intake and flue exhaust ducts have obstructions, signs of corrosion, physical damage, water spots or signs of rust.
2. - Make sure the externally assembled intake grids and flue exhaust outlets have no residue and are clean.

17.1.3 - Checking the system water pressure

- 1.- Make sure the system is full of water and under pressure as shown in section 18 technical features.
- 2.- Make sure there are no leaks in the hydraulic connections.



ATTENTION!!! Repair any system or appliance leaks. Continuously adding new water leads to increased minerals that reduce the flow cross-section, decreasing heat exchange and causing the heat exchanger to overheat. All of this leads to failures and reduced appliance life.

17.1.4 - Checking the ignition and detection electrodes

- 1.- Remove the burner fan unit (as shown in section 17.3).
- 2.- Clean any operating material build-up from the electrodes.
- 3.- Make sure the electrodes are in the correct position as shown in section 17.5.

17.2 - Disassembling the casing and accessing the inner components

To disassemble the casing, proceed as follows (refer to figure 17-1):

- 1.- Lift cover "A";
- 2.- Unscrew screws "B";
- 3.- Lower front casing "C";
- 4.- Remove lower casing "E";
- 5.- Open panel "D" by unscrewing the fixing screw located on the left and turning it as shown in the figure.
- 6.- Unscrew screw "G";
- 7.- Lift cover "F";

17 - MAINTENANCE

17.3 - Disassembling the burner fan unit

To disassemble the burner fan unit, proceed as follows:

- 1.- close the gas supply isolation valve and isolate the electrical supply to the appliance;
- 2.- access the inner components following section 17.2;
- 3.- disassemble spark generator "A" in figure 17-2, unscrewing screws "D" in figure 17-2 and disconnecting it from the ignition electrode.
- 4.- disassemble air manifold "A" in figure 17-3, turning it clockwise then removing it towards the left;
- 5.- unscrew nut "H" in figure 17-4, being careful of the gasket on the connection;
- 6.- with the aid of a flathead screwdriver, remove spring "A" in figure 17-4;
- 7.- remove the electrical plug from the gas valve;
- 8.- pull the gas valve out upwards, being careful of O-ring "L" (see figure 17-4);
- 9.- Unscrew the four nuts "B" in figure 17-5;
- 10.- remove the fan/burner unit (part "C" in figure 17-5).

Reassembling the fan/burner unit

To reassemble the burner/fan unit, work backwards compared to the disassembly operations and adopt the

following precautions:

- a - replace gasket "M" in figure 17-4, taking care to thoroughly clean the seat of said gasket, as well as the support seat.
- b - check the state of the gasket of nut "H" and O-ring "L" in figure 17-4. If they are damaged, they must be replaced.
- c - Once everything has been reinstalled, open the gas supply isolation valve and check for leaks around nut "H" in figure 17-4.



ATTENTION!!! Only use a leak detection fluid when checking for leaks; using naked flames is absolutely prohibited.

17.4 - Cleaning the burner and the primary exchanger, flue gas side

To properly clean the burner and the exchanger body (flue gas side), proceed as follows (refer to figure 17-5 when not otherwise specified):

- 1.- access the inner components following section 17.2;
- 2.- disassemble the fan burner unit following section 17.3;
- 4.- run a cylindrical brush with nylon bristles inside combustion chamber "H"



ATTENTION !!! DO NOT use metallic brushes. Only use brushes with nylon or equivalent material bristles.

- 5.- using a vacuum cleaner with brush attachment, remove

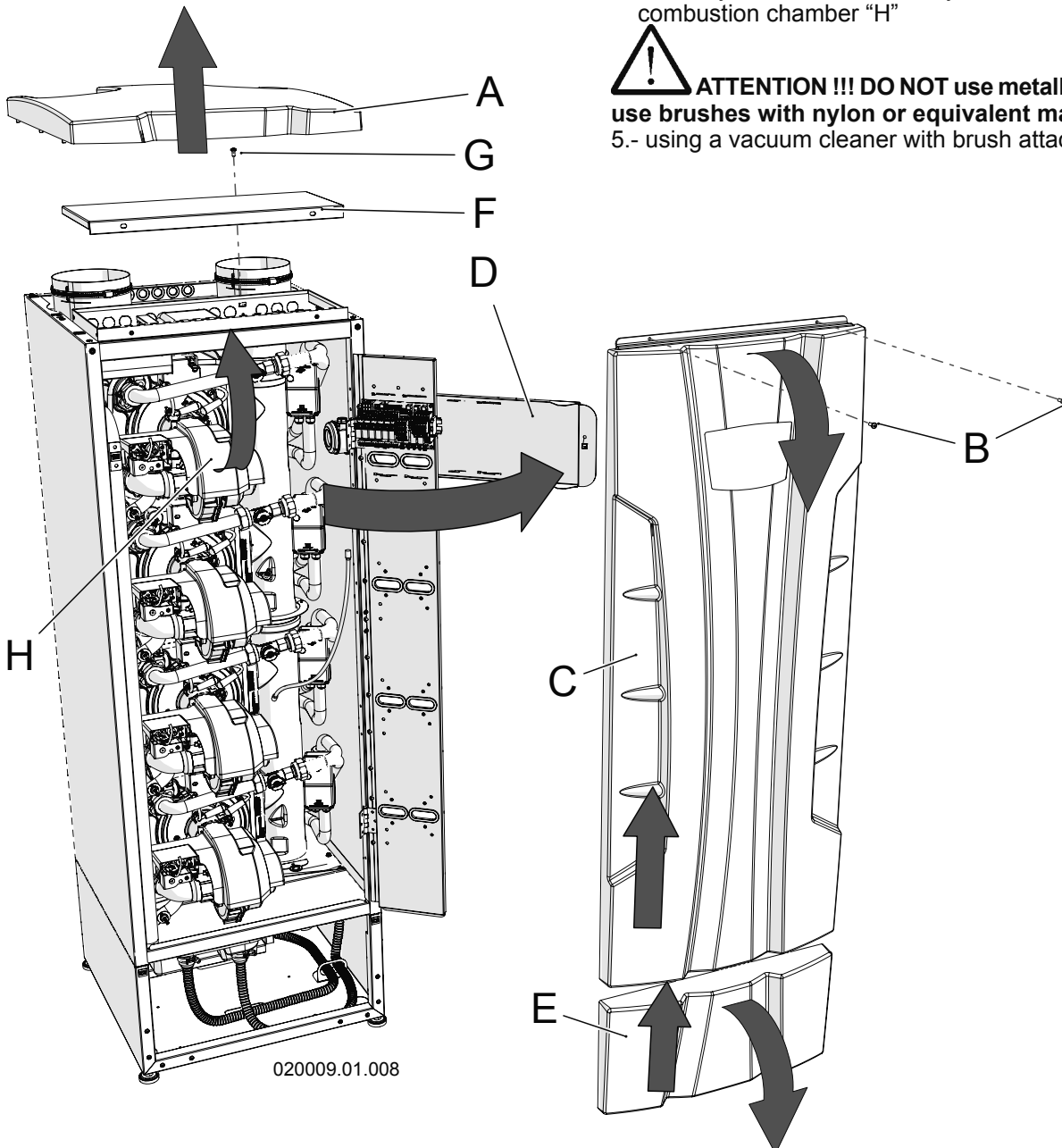

Figure 17-1 - Disassembling the casing and opening the control panel

17 - MAINTENANCE

- the unburnt residues inside combustion chamber "H";
- 6.- using the same cleaner, vacuum the surface of the burner and around the electrodes;
 - 7.- reassemble the components in reverse order;
 - 8.- open the gas supply isolation valve;
 - 9.- reconnect the electrical supply.
 - 10.- make sure there are no gas leaks between the removed joints;

⚠ ATTENTION !!! Only use a leak detection fluid when checking for leaks; using naked flames is absolutely prohibited.

⚠ ATTENTION !!! Every time you clean the burner

and the main exchanger, you must first make sure heat insulators "R" and "S" are in good condition (see figure 17-5). If necessary, replace them along with burner gasket "T" (see figure 17-5), requesting the specific kit, code 62632006.

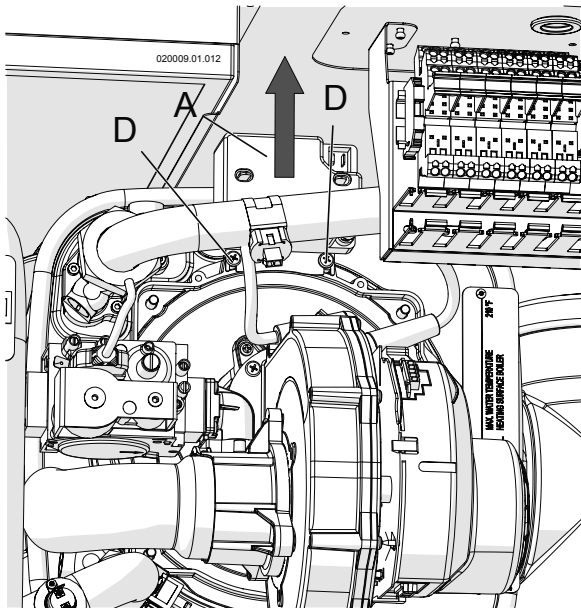

Figure 17-2 - Spark generator disassembly

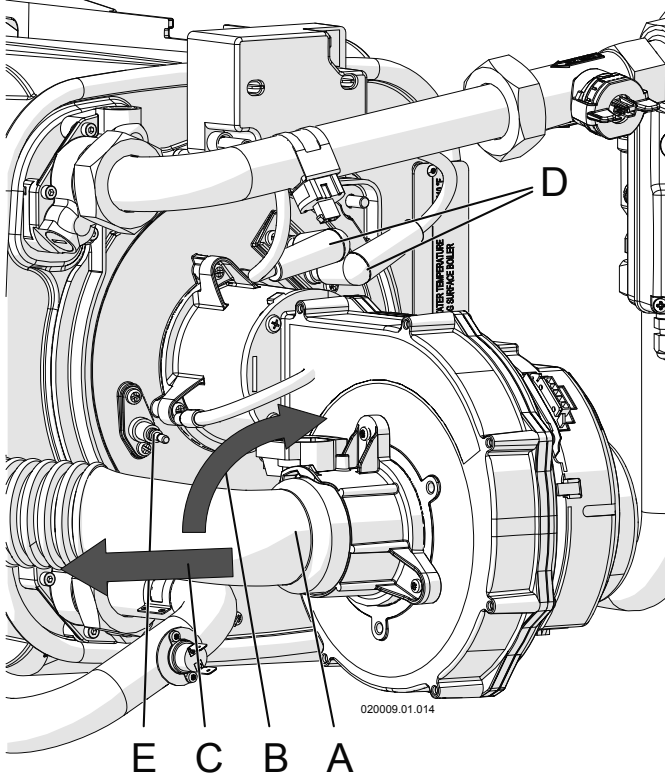
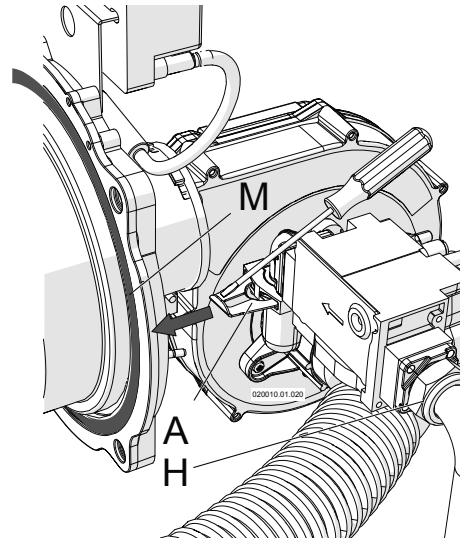

Figure 17-3 - Air manifold disassembly

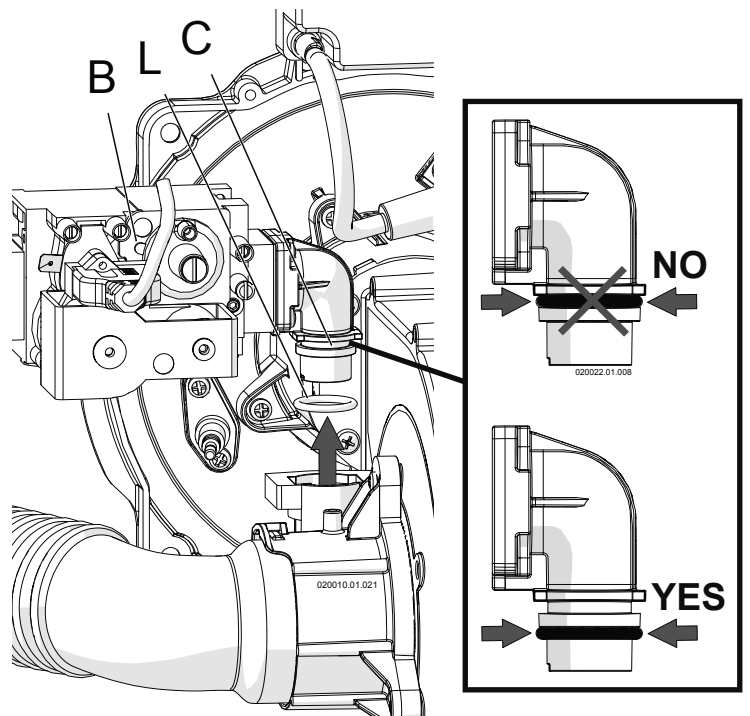

Figure 17-4 - Gas valve disassembly

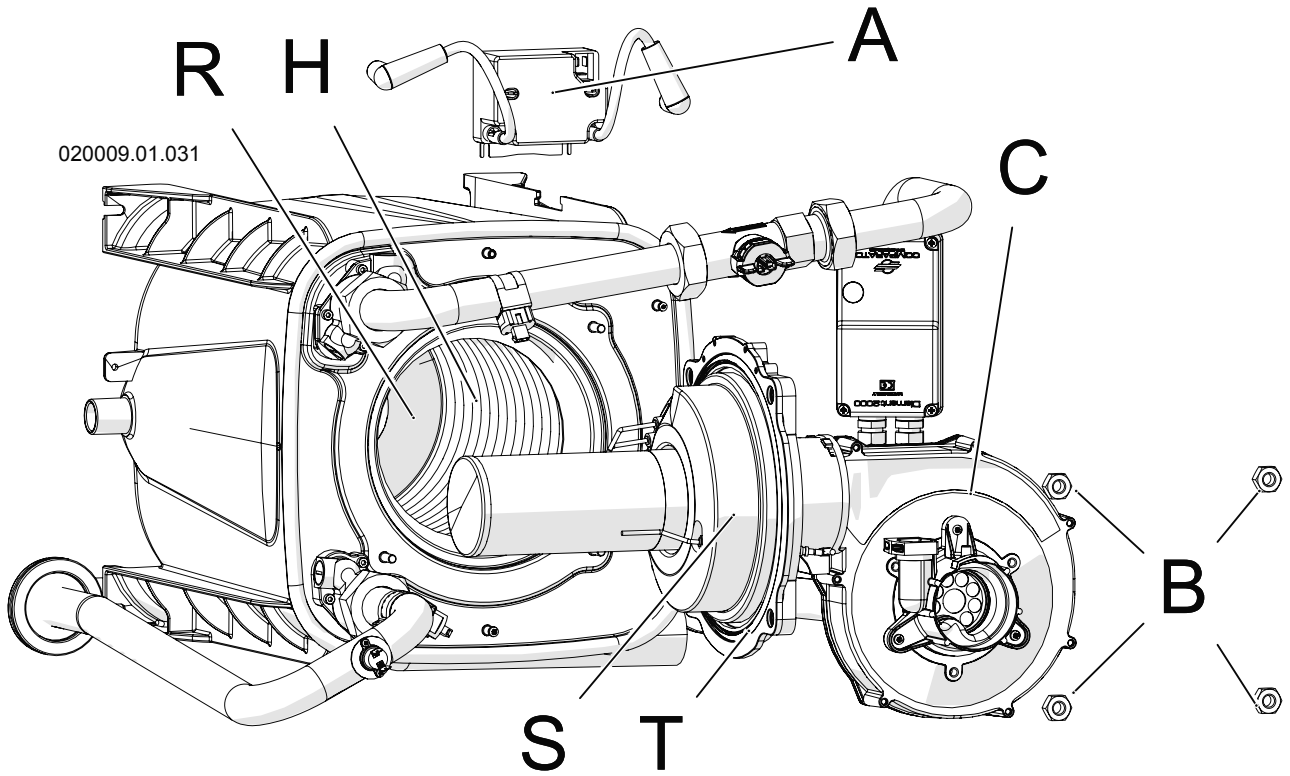
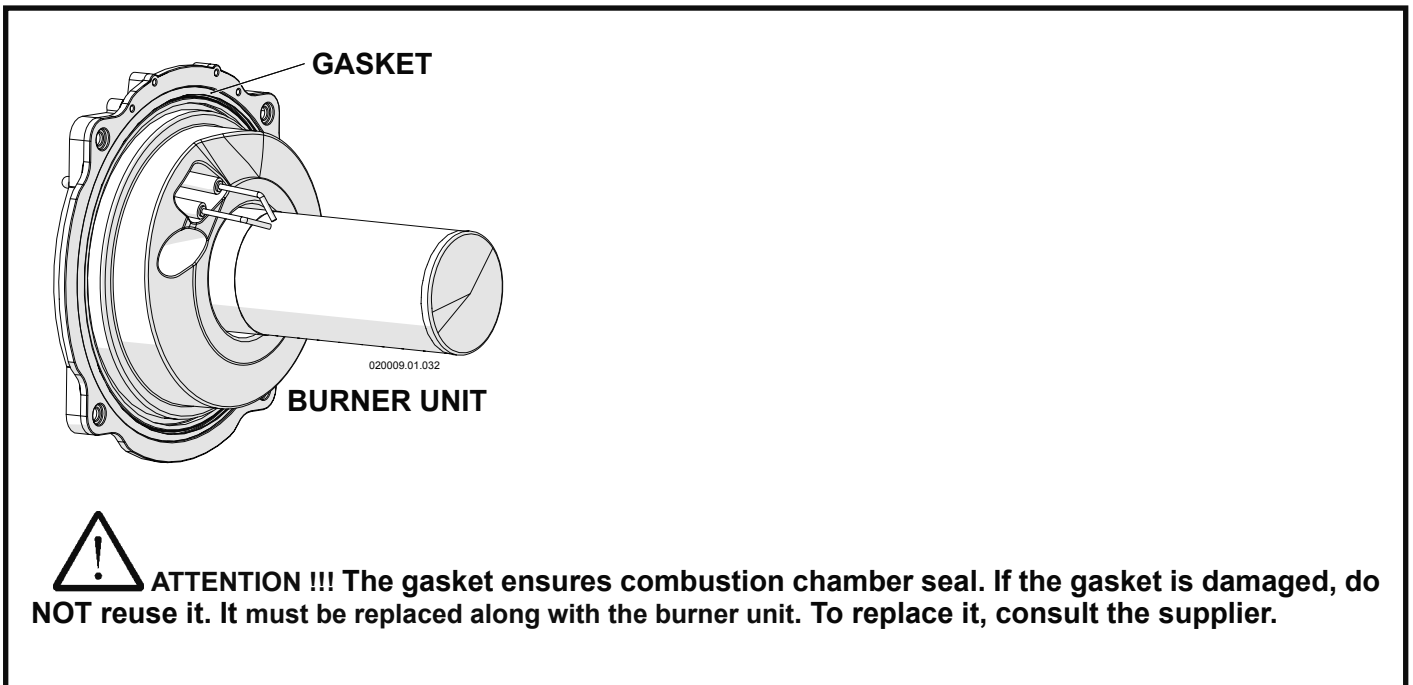

Figure 17-5 - Disassembling the burner fan unit



17 - MAINTENANCE

17.4.1 - Thermal insulations

Thermal insulations must be checked every year and replaced if they are cracked or damaged. See Figures below where the thermal insulations (items "C" and "E") are shown already disassembled from heat exchanger and burner. For replacement information see the spare parts section.

- A = Fixing screw
- B = Washer
- C = Thermal Insulation
- D = Stainless steel tube
- E = Thermal Insulation
- F = White thermal insulation
- G = Burner
- H = Gasket
- L = Ignition electrodes
- M = Screws
- N = Detection Electrode
- Q = White thermal insulation
- R = Gasket
- S = Gasket

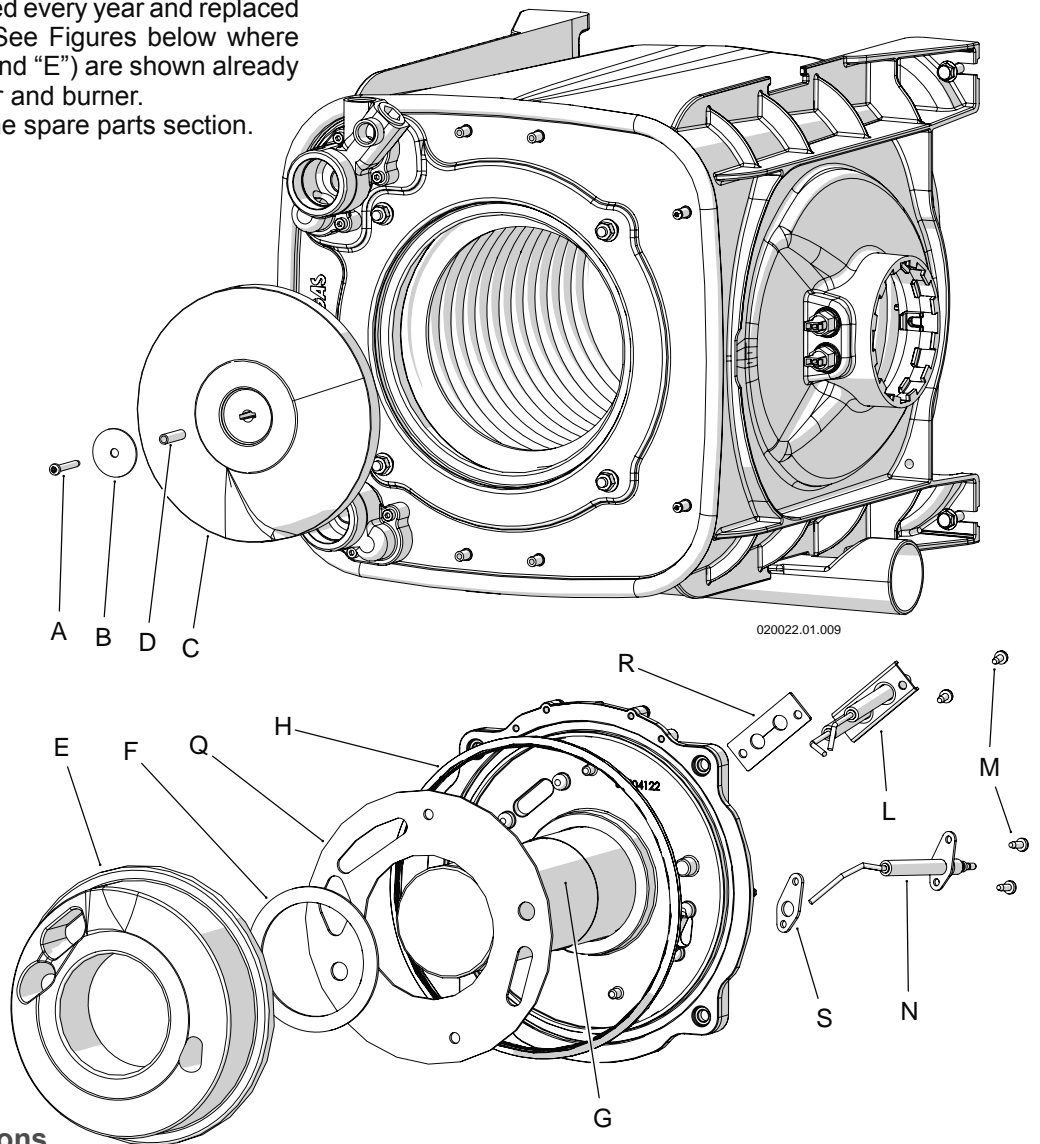
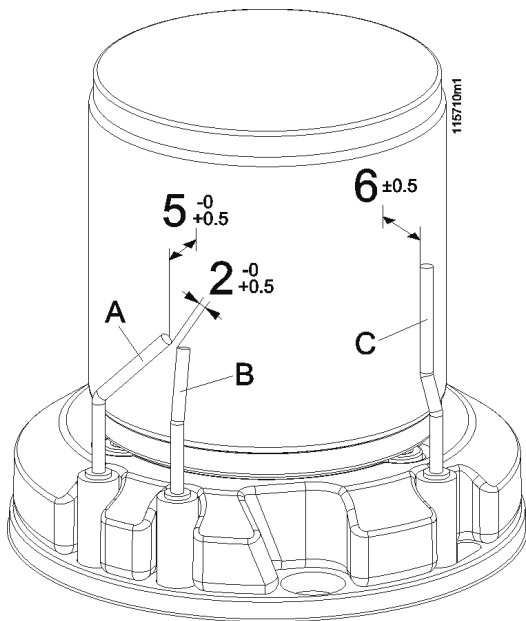

Figure 17-6 - Thermal insulations



- A - LH ignition electrode
- B - RH ignition electrode
- C - Detection electrode

Figure 17-7 - Positioning electrodes on the burner

17.5 - Positioning the ignition and ionisation electrodes properly

- For the appliance to ignite reliably, it is essential for the electrodes to be positioned properly (refer to figure 17-7):
- the distance between ignition electrodes "A" and "B" must be between 2.0 and 2.5 mm;
 - the distance of the ignition electrodes from the burner surface must be between 5 and 5.5 mm;
 - the distance of the ionisation electrode from the burner surface must be between 5.5 and 6.5 mm.

To accurately position the electrodes, it is a good idea to use a digital calliper to achieve the tolerances shown in figure 17-7.

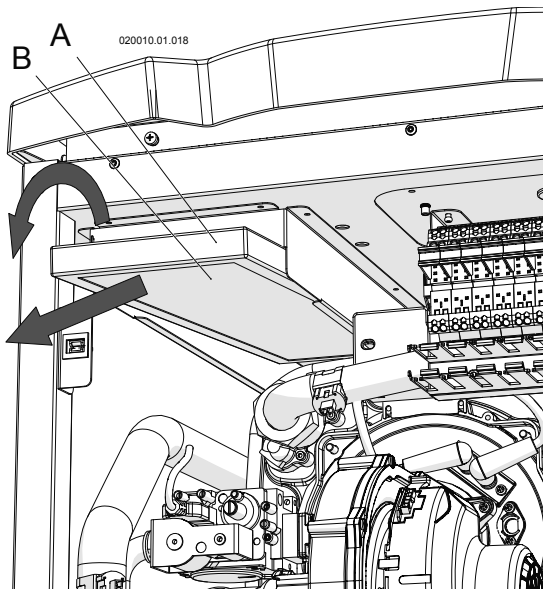

Figure 17-8 - Air intake filter disassembly

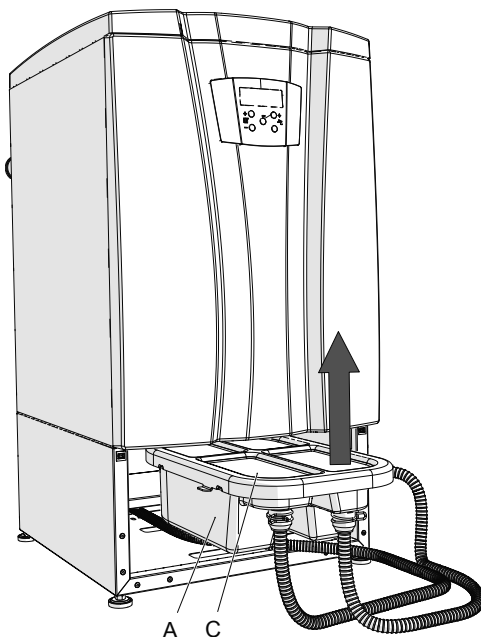
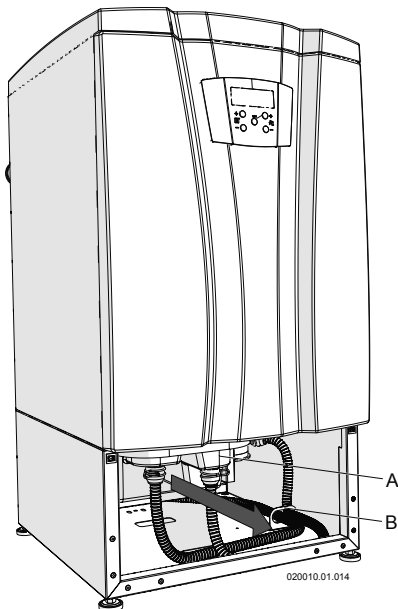

Figure 17-9 - Disassembling and opening the condensate neutraliser box

17.6 - Cleaning the air intake filter

- The air filter must be cleaned for the appliance to work properly. Refer to figure 17-8 and proceed as follows:
- 1.- access the inner components of the appliance by following section 17.2;
 - 2.- slide out the filter, part "A", as shown in the figure;
 - 3.- clean the filter with compressed area until all debris has been removed;
 - 4.- reassemble the filter and the appliance casing.

17.7 - Condensate drain system maintenance and cleaning

During appliance maintenance, the condensate drain pipe (part "5" in figures 3-3, 3-5 and 3-7) must be disassembled and any residue cleaned. Reassemble the clean pipe and **restore the liquid level in the water trap as per section 15.1.1.**

Check the pH level every three months for the first year. To run the test, you can use specific litmus test strips or a specific electronic instrument that allows for more accurate measurement (access the box via plug "E" in figure 12-1). The subsequent frequency of these checks can be reduced to every six months or year, depending on local and national regulations. The neutralising content of the box must be replaced when the pH level drops below the level required by local and national regulations.

To replace the neutraliser, proceed as follows:

1. Follow the guidance given in section 17.2 to remove covering "E" in figure 17-1;
2. Extract box "A" (figure 17-9);



ATTENTION !!! When removing the box, take care to tilt it in order to prevent the liquid from spilling, which could cause damage.

3. Open cover "C" (figure 17-9) upwards;
4. Make sure the box is in good condition;
5. Make sure the neutralising material is in good condition and, if necessary, add or replace it;
6. Fill it with fresh water until the water begins to flow out of the drain;
7. Reposition the box in the correct seat;



ATTENTION !!! The neutralisation box must be filled with water to prevent gas from leaking out of the drain during unit operation.

8. Open the gas supply;
9. Restore power to the appliance.



ATTENTION !!! Follow figure 17-9 carefully to but box "A" back in the right position. **After the above maintenance, restore the liquid level in the water trap as per section 15.1.1.**

17 - MAINTENANCE

17.8 - Connecting the Display to the other burners

In 140T to 280T appliances, being multi-burners, the display in figure 16-1 is always connected directly to "Burner 1 (Master)". All the parameters that can be consulted on the display (sections 16.14, 16.15 and 19) that refer to Burner 1 (Master) exclusively concern this burner. If you wish to see/change the same parameters for the other burners, you must move the display connection from "Burner 1 (Master)" to the burner you wish you view/edit; proceed as follows: (refer to figure 17-10):

1. Disconnect power to the appliance;

2. Follow the guidance given in section 17.2 to access the inner components;
3. Disconnect terminal "B" (coming from the display) from terminal "A" (coming from "Burner 1 (Master)");
4. Connect terminal "B" to terminal "C", "D" or "E", depending on which burner you wish to view or edit, considering that: terminal "C" is for "Burner 2"; terminal "D" is for "Burner 3" and terminal "E" is for "Burner 4"
5. Once the terminal is connected to the burner to be checked, reconnect the power supply to the appliance and switch it on;
6. The display will now show all the information regarding the connected burner. Make all consultations or modifications following what is described in sections 16.14, 16.15 and 19.
7. Once the check is complete, reconnect terminal "B" to terminal "A" as it was previously.

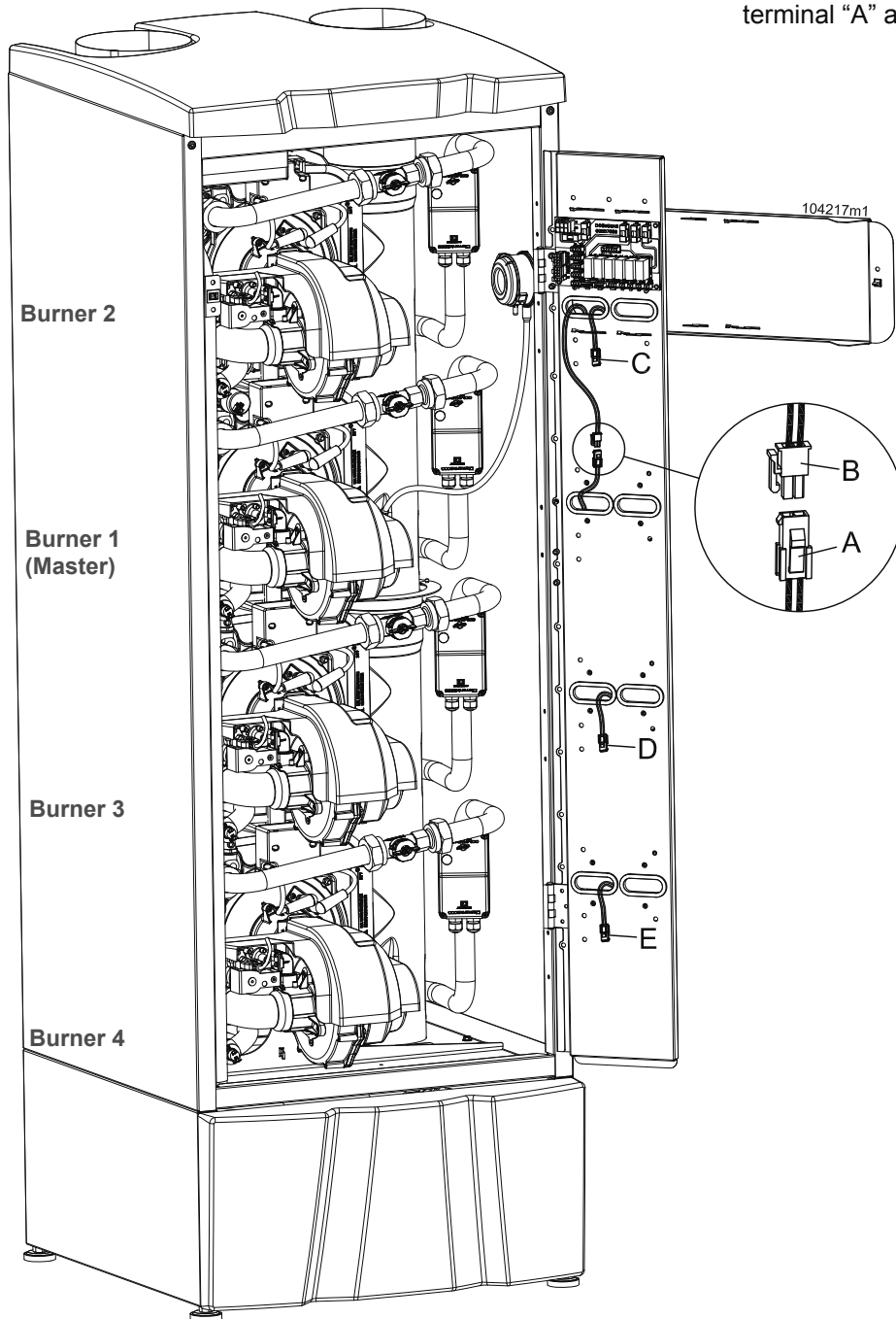

A = Connector for Burner 1 (Master) dialogue

B = Connector from display

C = Connector for Burner 2 dialogue

D = Connector for Burner 3 dialogue (Only in 210T and 280T models)

E = Connector for Burner 4 dialogue (Only in 280T models)

Figure 17-10 Connecting the display in the other burners

17 - MAINTENANCE

17.9 - How to move a control board

140T to 280T model appliances are configured to be managed by a control board (Burner 1 Master). All the devices are connected on this board: room thermostat, external temperature sensor, pump controls, external safety devices and all the internal safety devices: condensate level sensor, flue exhaust differential pressure switch, etc.

If the Burner 1 control board has an error, the appliance stops working. If the technician does not have spares to replace the board, he/she can temporarily replace it with one of the boards from another burner in the appliance so that the system can be restarted.

To this end, proceed as follows:

(when not otherwise specified, refer to figure 17-10)

1. Turn off the main switch and disconnect power;
2. access the inner components following what is described in section 17.2;
3. Disconnect connector "B" (connector coming from the display) to connector "A" (connector coming from "Burner 1 (Master)");
4. Disconnect all the other connectors from the Burner 1 (Master) control board;
5. Remove the Burner 1 (Master) control board from the appliance;
6. Follow points 3 to 5 to remove the control board from the burner positioned lower;
7. Assemble the board in place of the Burner 1 (Master) board;
8. Restore all the connections in the new Burner 1 (Master) board;

9. Move selector "S4" as shown in figure 17-11 from the OFF position to the new ON position;
10. Be very careful with the connectors from the board that was removed. They must be insulated to avoid short circuiting and damage;
11. Electrically insulate each of these connections;
12. Replace the appliance casing;
13. Reconnect power and turn on the appliance main switch;
14. Access the forced menu, follow section 19 and set all the parameters as per the "Burner 1 (Master)" column.

Parameter **3050** must be reduced by a unit compared to the previous state, as the appliance now has one less Slave Burner.

15. Disconnect the power supply;
16. Reconnect the power supply to the appliance; the new Burner 1 control board now controls the appliance.

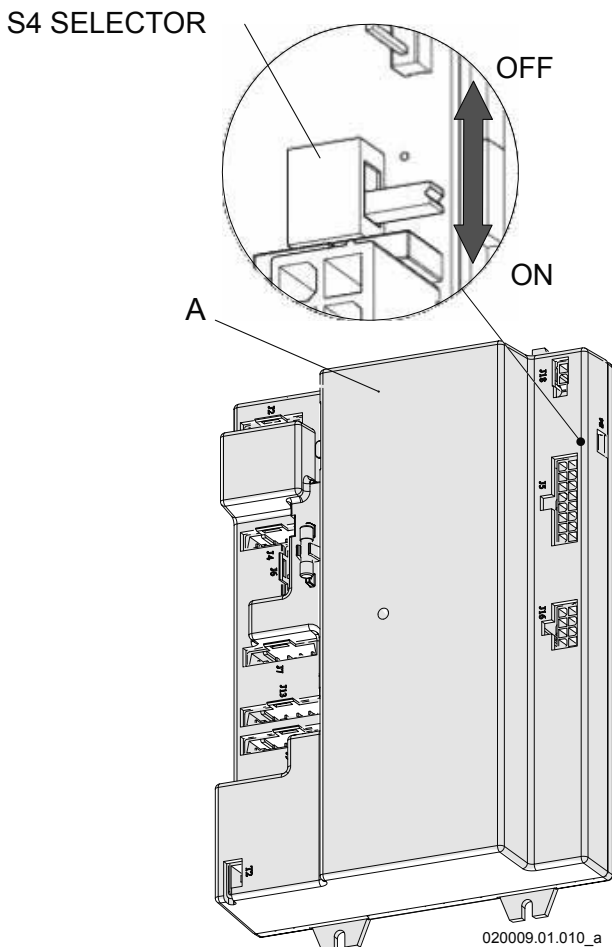

Figure 17-11 - Command board

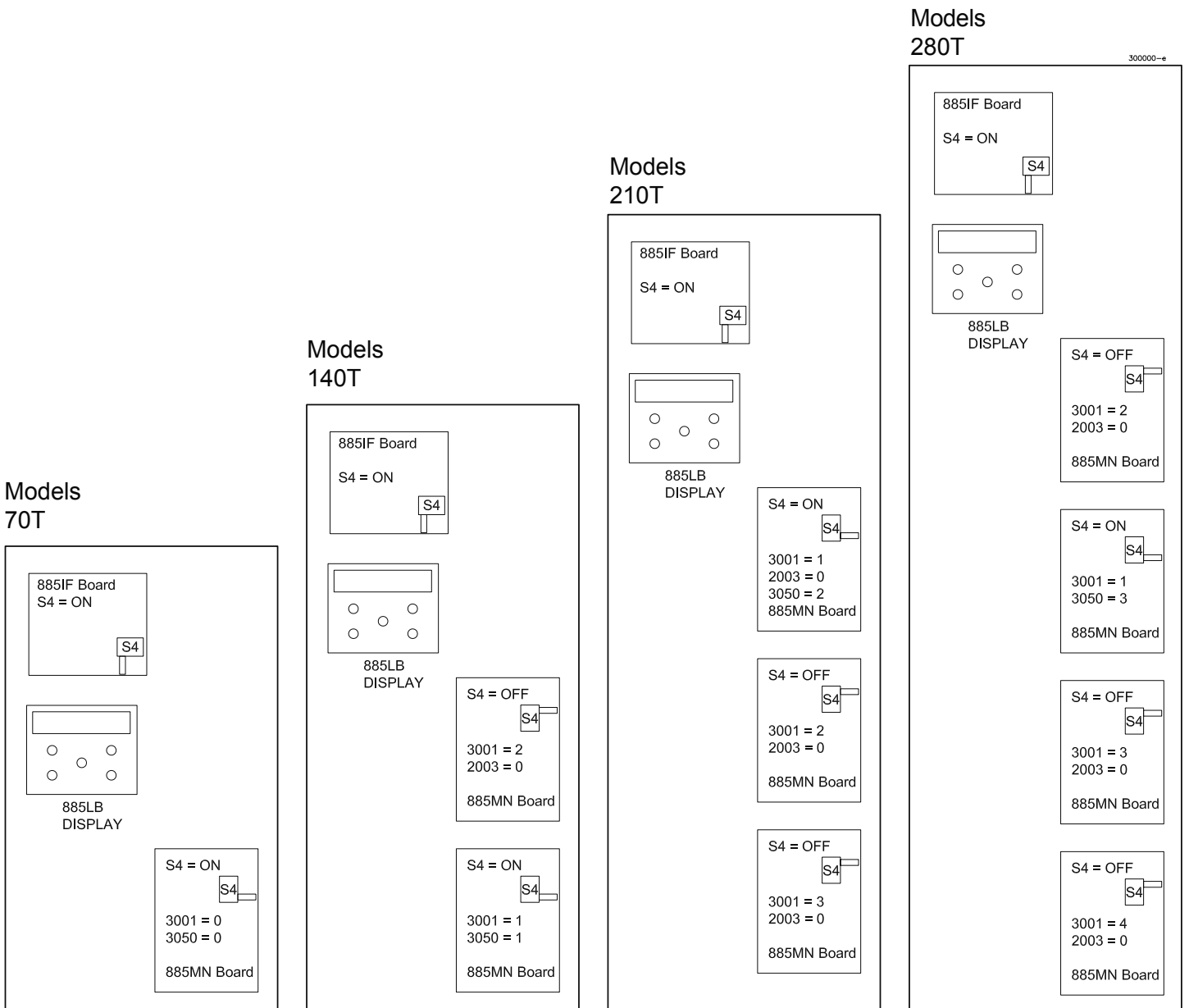

Figure 17-12 Setting parameters 3001, 3050 and selectors S4

17 - MAINTENANCE

17.10 - Emptying the appliance

- 1.- generate a heating demand by increasing the domestic hot water and heating temperature (also close any room thermostat bridges in the boiler version);
- 2.- wait for the burner to ignite (in the multi-burner versions, wait for all the burners to ignite) (make sure as many corresponding "L" icons in figure 16-1 as burners are on);
- 3.- switch off the appliance. This way, any motorised valves stay open);
- 4.- ensure any filling loop or automatic top-up system is isolated;
- 5.- connect a flexible rubber hose to the drain valves "38" in figures 3-3, 3-5 and 3-7, and direct it to a suitable drain in the plantroom;
- 6.- wait for the water inside the appliance to cool to below about 40°C;
- 7.- open the drain cocks slowly;
- 8.- open the heating element bleed valves. Start from the higher heating elements and continue with the lower ones.
- 9.- once all the water has been drained, close the bleed valves on the heating elements and the drain cocks provided for by the installer.



ATTENTION!!! On heating boilers, the water within the system will be contaminated with dosing chemicals and system residues and therefore must only be disposed of in a foul water drain. Do not discharge the water in to a grey-water or surface water system.

17.11 - Minimum and maximum output heat

It is possible to force operation to minimum, maximum or ignition output heat. Proceed as follows:

- 1.- make sure the heat generated by the appliance can be dissipated by the system;



ATTENTION!!! During forced operation, the supply temperature is automatically set to 93°C to allow the heat generated by the appliance to be dispersed as much as possible. Make sure all components within the system can withstand this temperature.

- 2.- access parameter 2010 (2002 for multi-burner models) located in the "installer menu" (see section 16.15);
- 3.- set the parameter to the following value:
 - a) LOu to force the burner, or all the burners, to minimum output heat;
 - b) Ign to force the burner, or all the burners, to ignition output heat;
 - a) High to force the burner, or all the burners, to maximum output heat;
- 4.- To end forcing, bring parameter 2010 (2002 for multi-burner models) back to OFF and press the RESET key.



ATTENTION!!! If, during forcing, the output heat dispensed by the appliance is much greater than the output heat absorbed by the system, the appliance switches off continuously to reach the maximum allowed temperature (93°C).

The same procedure above can also be applied to 140T to 280T model multi-burner appliances but consider that only one burner can be forced at a time, by moving the display from one burner to another, as described in section 17.8.

17.12 - Checking the ionisation current

At any operating state, even during maximum and minimum output heat checks as per section 17.11, it is possible to see

the ionisation current value on parameter 1008 in the "user menu" (section 16.14). This value must be between 4 and 7 uA (microamperes).

Please note that parameter 1008 on multi-burner appliances (models from 140T to 280T) corresponds to Burner 1 (Master), in order to check the other burners, you must refer to section 17.8.

17.13 - Checking combustion performance

National regulations on gas appliances require combustion ratios to be checked; with a maximum interval of 12 months.

The testing procedure is described in section 15.8.

Along with the combustion ratios, the combustion efficiency should be checked and, must be greater than 96% (net).

17 - MAINTENANCE

17.14 - Temperature and water measurement sensors

There are various temperature sensors on the exchanger body. The electrical resistance between the two sensor contacts must match what is shown in figure 17-13. The digital readings of the temperature sensors are given in parameters: 1001, 1002, 1006 and 1007

17.15 - External temperature sensor

The external temperature sensor (see section 13.1.4) is available as an ancillary option. When fitted, the digital reading will be given in parameter 1004.

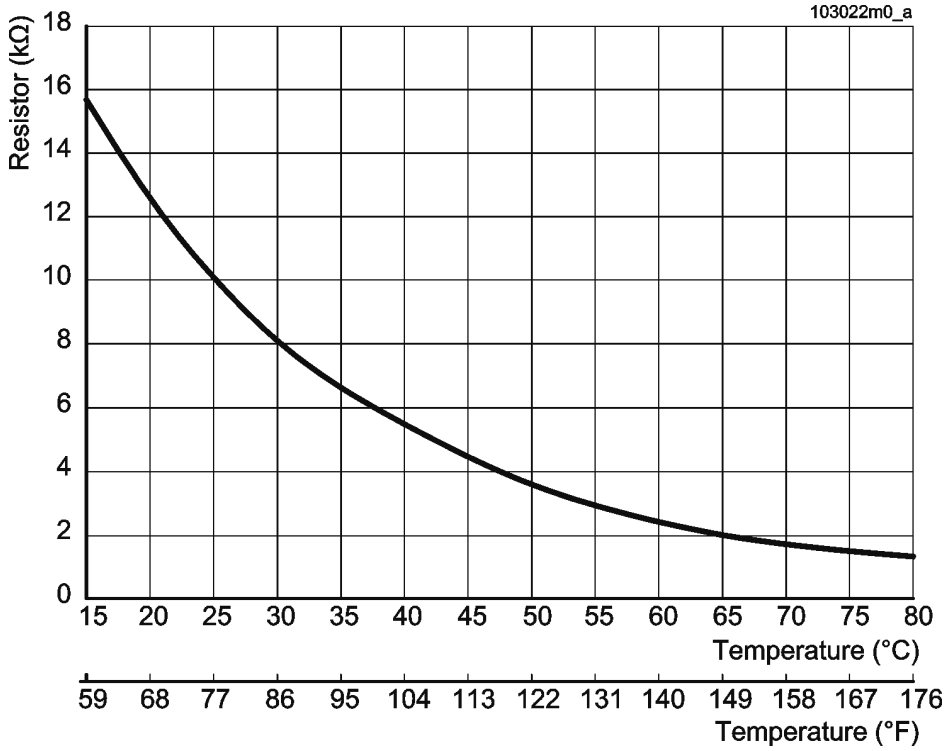

Figure 17-13 - Water sensor curve

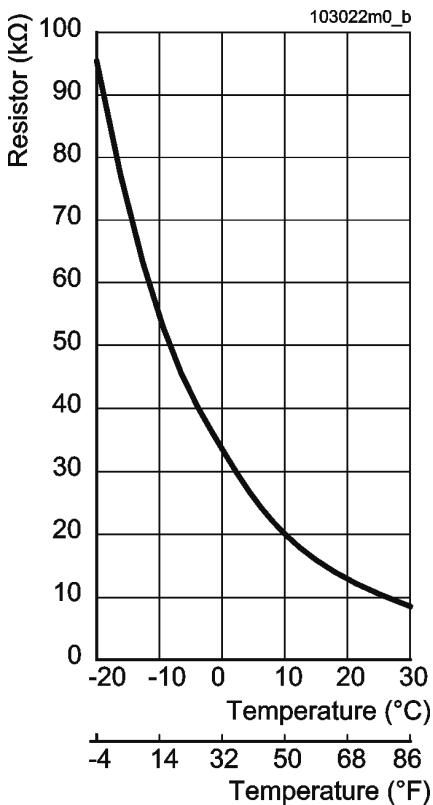

Figure 17-14 - External temperature sensor curve

17.16 - 70T models multi-line wiring diagram

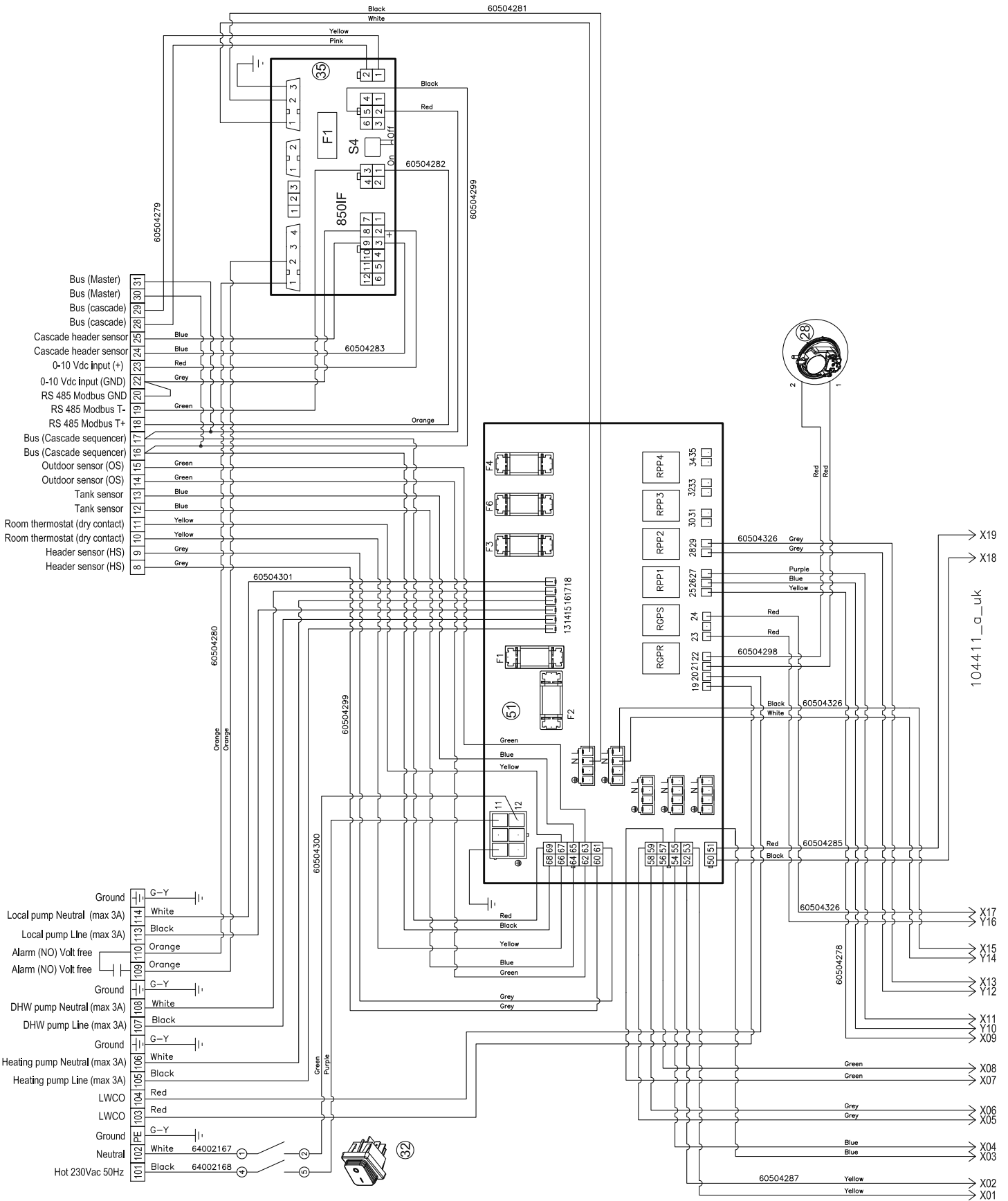

Figure 17-15 - Multi-line wiring diagram part 1 - continues on the following page

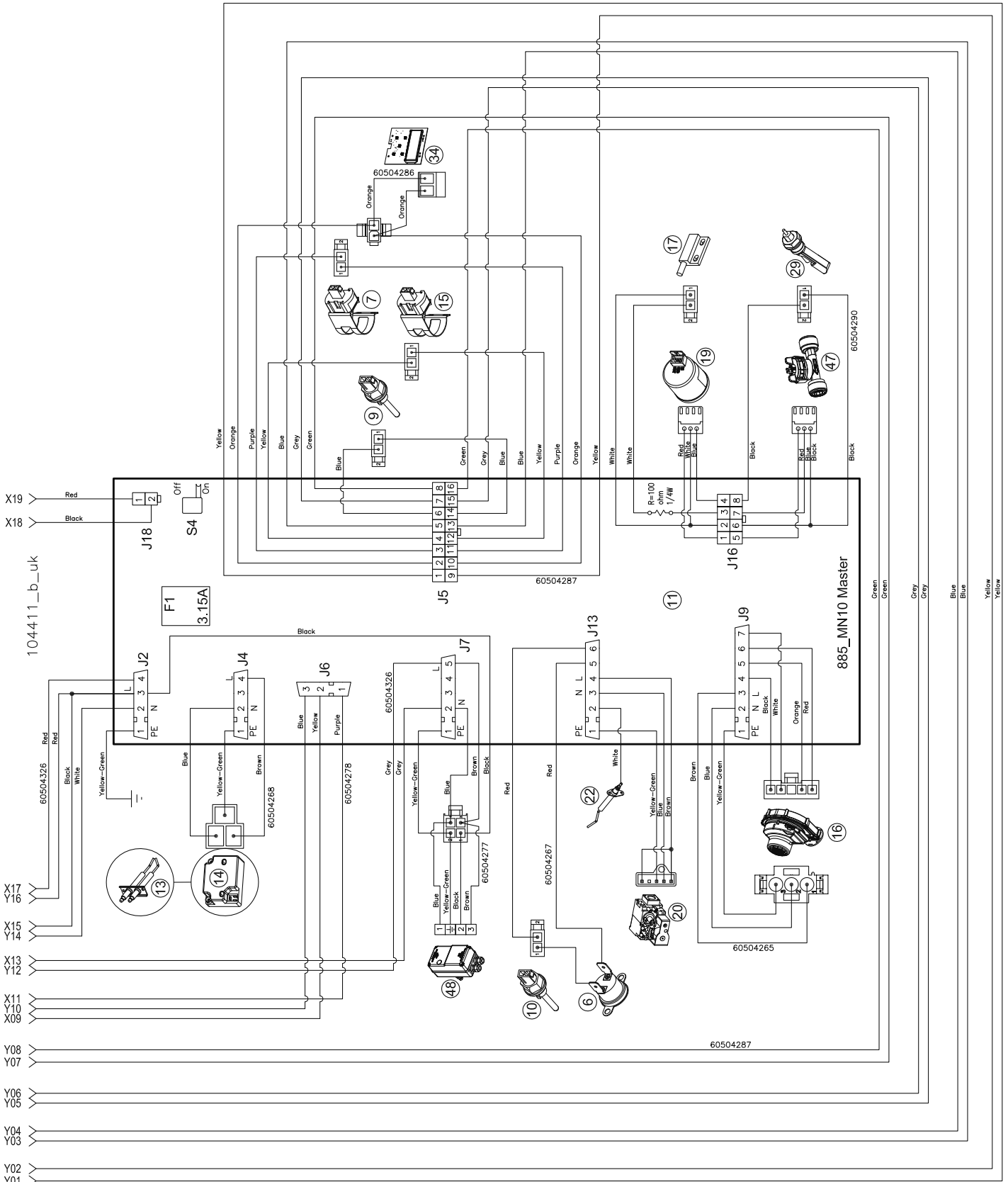

Figure 17-15 - Multi-line wiring diagram part 2 - continued from the previous page

17.17 - 140T,210T and 280T models
multi-line wiring diagram

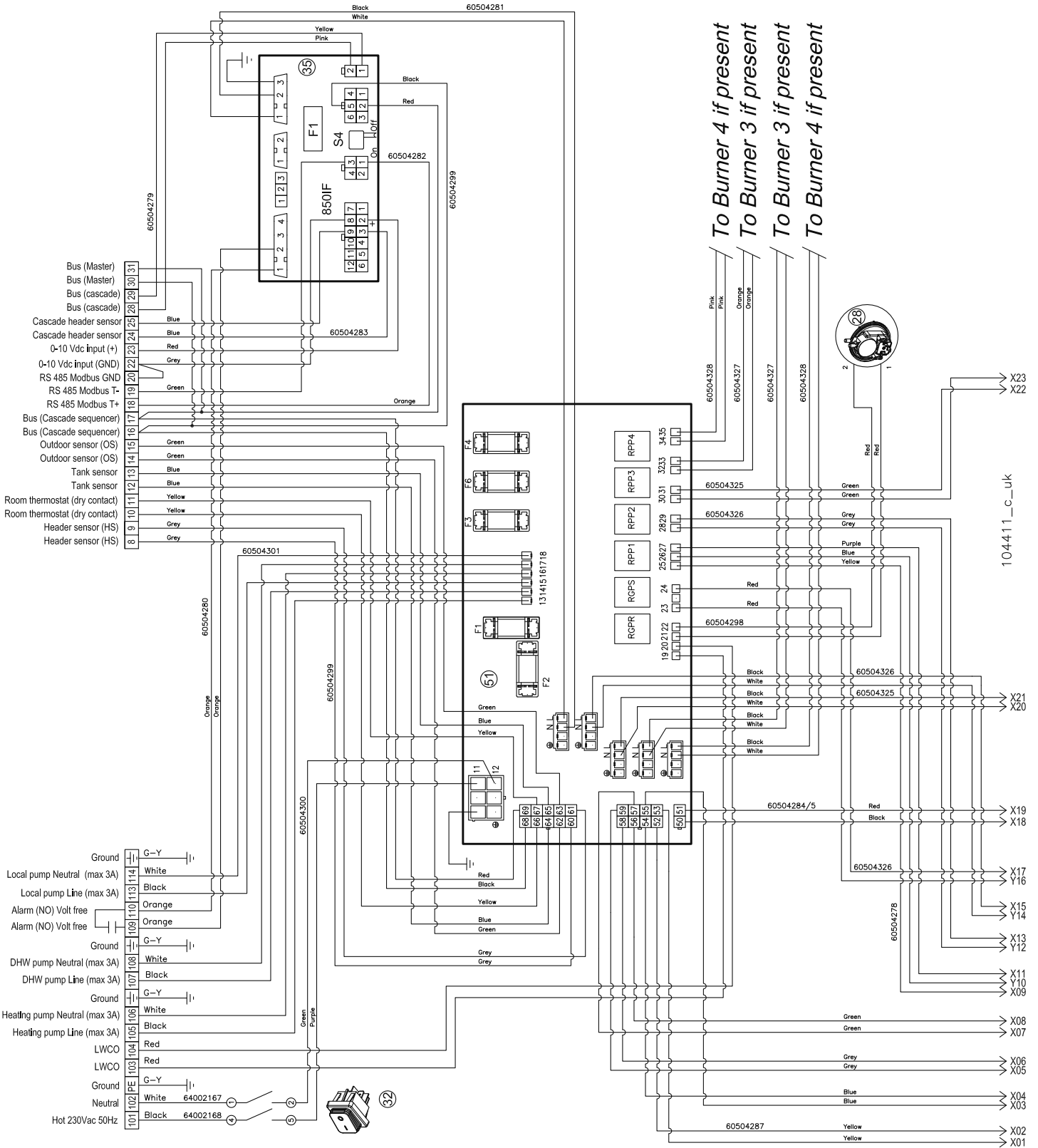
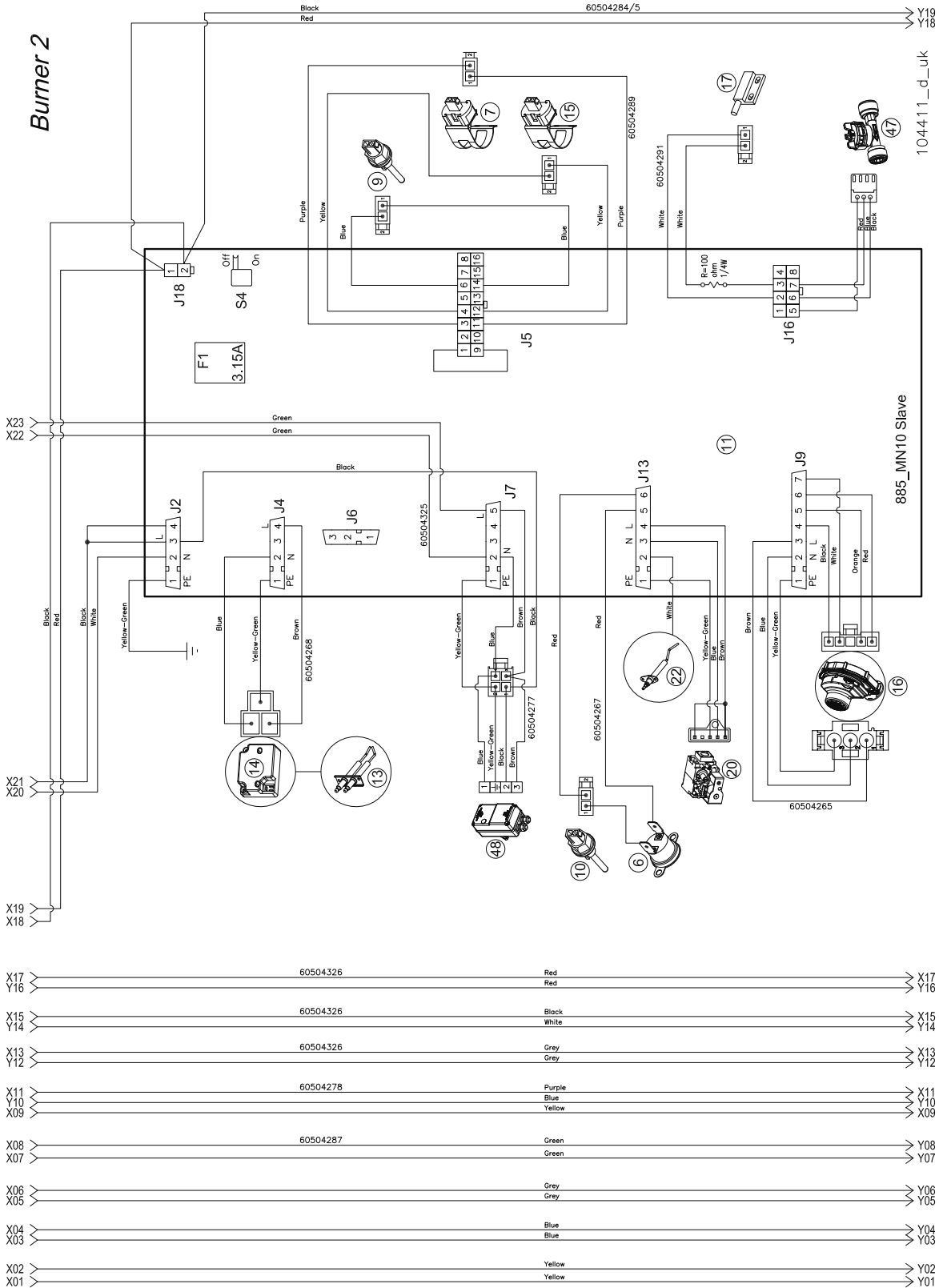

Figure 17-16 - Multi-line wiring diagram part 1 - continues on the following page



Continues

Figure 17-16 - Multi-line wiring diagram part 2 - continues on the following page

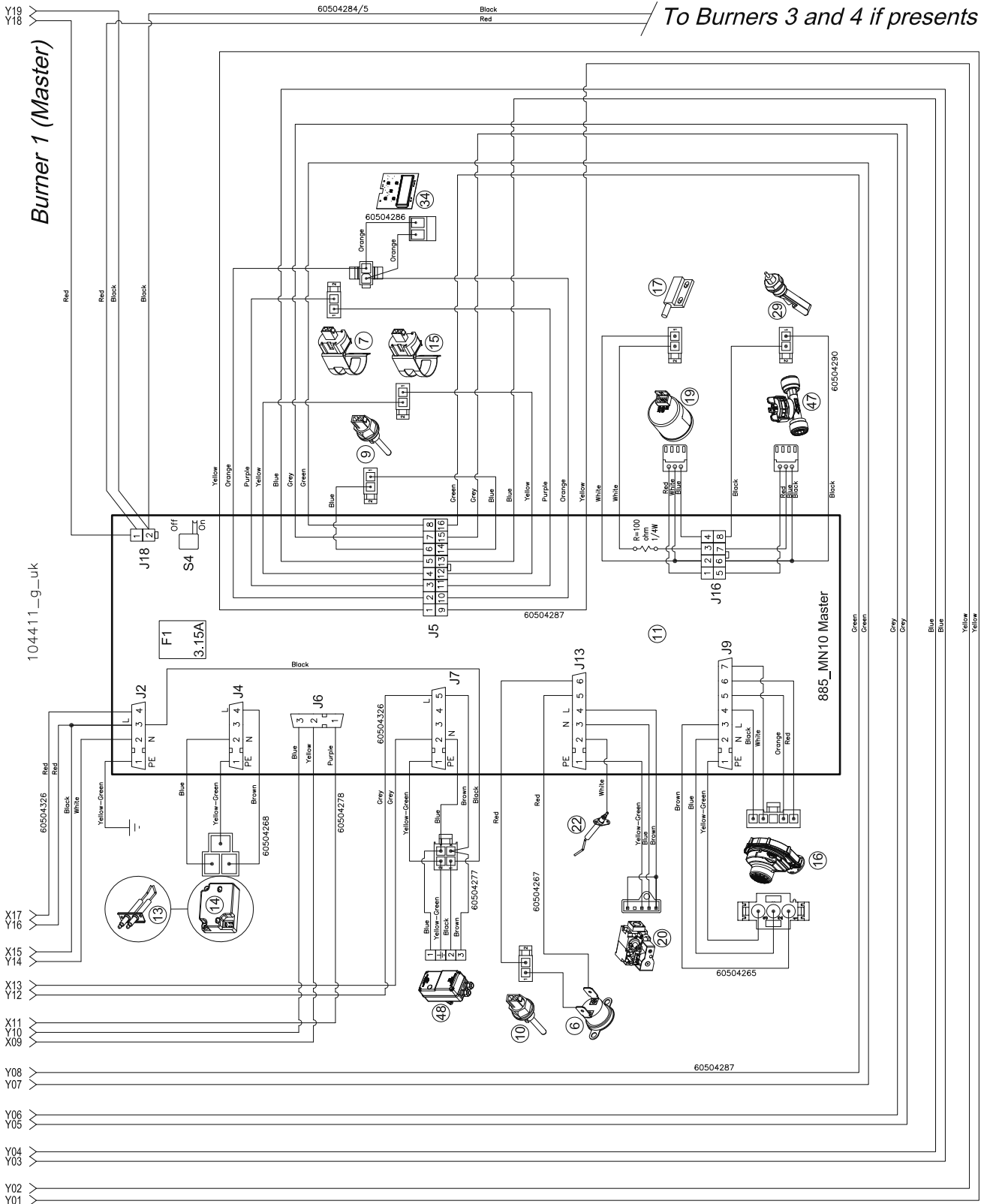

Figure 17-16 - Multi-line wiring diagram part 3 - continued from the previous page

17 - MAINTENANCE

Figures 17-15 and 17-16 wiring diagram key

- 6 - Water outlet safety thermostat
- 7 - Water outlet temperature sensor
- 9 - Flue exhaust temperature sensor
- 10 - Flue exhaust temperature safety fuse
- 11 - Command and control board
 - Fuse - F1 5x20 3A
- 13 - Ignition electrodes
- 14 - Spark generator
- 15 - Water inlet temperature sensor
- 16 - PWM modulating fan
- 17. Flapper valve
- 19 - Water pressure measuring device
- 20 - Gas valve
- 22 - Detection electrode
- 28 - Flue exhaust differential pressure switch
- 29 - Condensate level sensor
- 32 - Main ON/OFF switch
- 34 - Display
- 35 - 885 IF board
 - Fuse - F1 5x20 3A
- 47 - Water flow rate sensor
- 48 - Motorised two-way valve (on request)
- 51 - Connection diagrams
 - Fuse - F1 5x20 10A
 - Fuse - F2 5x20 10A
 - Fuse - F3 5x20 3A
 - Fuse - F4 5x20 3A
 - Fuse - F6 5x20 3A
- RGPR - Heating circuit pump relay
- RGPS - Domestic hot water circuit pump relay
- RPP1 - Burner 1 (MASTER) main circuit pump relay
- RPP2 - Burner 2 main circuit pump relay
- RPP3 - Burner 3 main circuit pump relay
- RPP4 - Burner 4 main circuit pump relay

18 - TECHNICAL FEATURES

18.1 - TECHNICAL FEATURES MYDENS

TECHNICAL FEATURES MYDENS		UM	70T	140T
Destination country			UK; IE	UK; IE
Type (Flue exhaust/air intake type)			B23; C43 ; C53 ; C63; C83	
Category			I12H3P	I12H3P
CE-type Certificate (PIN)			0476CR1272	0476CR1272
Range Rated Certificate			APPROVED	APPROVED
Maximum heating input heat "Q"		kW	70.0	140.0
Minimum heating input heat		kW	14.7	14.7
Maximum output heat (80/60) "P"		kW	67.9	135.8
Efficiency at 100% load (80/60)		%	97	97
Minimum output heat (80/60)		kW	14.1	14.1
Efficiency at minimum output heat (80/60)		%	96	96
Maximum output heat (50/30)		kW	74.0	148.0
Efficiency at maximum output heat (50/30)		%	106	106
Minimum output heat (50/30)		kW	15.6	15.6
Efficiency at minimum output heat (50/30)		%	106	106
Efficiency at 30% load		%	106	106
Chimney loss burner on (80/60)		%	1	1
Chimney loss burner on at minimum output heat		%	0.5	0.5
Chimney loss burner off		%	0.1	0.1
Casing loss burner on		%	0.1	0.1
Casing loss burner off		%	0.05	0.05
Loss at no load		%	0.05	0.05
Gas flow rate	G20	m ³ /h	7.40	14.80
	G25	m ³ /h	8.61	17.22
	G30	kg/h	5.52	11.03
	G31	kg/h	5.43	10.87
Gas supply pressure	G20	mbar	20	20
	G25	mbar	25	25
	G30	mbar	30	30
	G31	mbar	37	37
Gas supply minimum pressure	G20	mbar	10	10
	G25	mbar	10	10
	G30	mbar	10	10
	G31	mbar	10	10
Gas supply maximum pressure	G20	mbar	45	45
	G25	mbar	45	45
	G30	mbar	45	45
	G31	mbar	45	45
Main exchanger water content		lt	7.57	15.14
Minimum operating water flow rate with motorised valve		l/h	1620	1620
Minimum operating water flow rate without motorised valve		l/h	1620	3240
D.H.W with storage tank adjustment range		°C	40 - 60	40 - 60
Maximum temperature for safety intervention		°C	95	95
Heating maximum temperature		°C	80	80
Heating minimum temperature		°C	20	20
"PMS" heating maximum pressure		bar	11	11
Heating minimum pressure		bar	1	1
Rated power supply voltage		V	230	230
Rated power supply frequency		Hz	50	50
Absorbed electrical power		W	150	300
Degree of electrical protection			IP20	IP20

18 - TECHNICAL FEATURES

18.1 - TECHNICAL FEATURES MYDENS

210T	280T
UK; IE	UK; IE
B23; C43 ; C53 ; C63; C83	
I12H3P	I12H3P
0476CR1272	0476CR1272
APPROVED	APPROVED
210.0	280.0
14.7	14.7
203.7	271.6
97	97
14.1	14.1
96	96
222.0	296.0
106	106
15.6	15.6
106	106
106	106
1	1
0.5	0.5
0.1	0.1
0.1	0.1
0.05	0.05
0.05	0.05
22.20	29.61
25.83	34.43
16.55	22.06
16.30	21.73
20	20
25	25
30	30
37	37
10	10
10	10
10	10
10	10
45	45
45	45
45	45
45	45
22.71	30.28
1620	1620
4860	6480
40 - 60	40 - 60
95	95
80	80
20	20
11	11
1	1
230	230
50	50
430	590
IP20	IP20

18 - TECHNICAL FEATURES

18.1 - TECHNICAL FEATURES MYDENS

TECHNICAL FEATURES MYDENS		UM	70T	140T
Burner electrical power		W	150	300
Electrical power absorbed by the pump		W	N.A.	N.A.
Air intake and flue exhaust duct diameter (split)		mm	80	110
Max. flue exhaust duct length (split)		m	10	10
Max. air intake duct length (split)		m	10	10
Equivalent length of one curve		m	4	4
Weighted CO (0% O ₂)	G20	ppm	15	15
Weighted NO _x (0% O ₂) (EN 483 class 5)	G20	ppm	15	15
CO ₂ (%) at minimum / maximum output heat	G20	%	8.5 / 8.7	8.5 / 8.7
	G25	%	8.3 / 8.8	8.3 / 8.8
	G30	%	10.1 / 10.6	10.1 / 10.6
	G31	%	9.8 / 10.2	9.8 / 10.2
O ₂ (%) at minimum / maximum output heat	G20	%	5.8 / 4.9	5.8 / 4.9
	G25	%	5.8 / 4.9	5.8 / 4.9
	G30	%	5.9 / 5.1	5.9 / 5.1
	G31	%	6.0 / 5.4	6.0 / 5.4
Maximum flue gas recirculation in case of wind		%	10	10
Maximum flue gas temperature at boiler outlet		°C	90	90
Minimum flue gas temperature at boiler outlet		°C	30	30
Δt temperature fumes/Return (at 100% of the load) (80/60)		°C	17	17
Δt temperature fumes/Return (at 30% of the load) (37/30)		°C	1	1
Flue gas mass flow rate		kg/h	115	230
Flue gas mass flow rate at minimum output heat		kg/h	25.4	25.4
Head available at exhaust		Pa	110	110
Maximum combustion air temperature		°C	40	40
Maximum CO ₂ content in combustion air		%	0.9	0.9
Maximum over-heating flue gas temperature		°C	92	92
Max. admissible vacuum in the flue exhaust/intake system		Pa	50	50
Maximum condensate flow rate		l/h	8.7	17.4
Condensate average degree of acidity		PH	4	4
Operating ambient temperature		°C	0 ; + 50	0 ; + 50
Boiler weight (empty)		kg	98	147

18 - TECHNICAL FEATURES

18.1 - TECHNICAL FEATURES MYDENS

210T	280T
430	591
N.A.	N.A.
160	160
10	10
10	10
4	4
15	15
15	15
8.5 / 8.7	8.5 / 8.7
8.3 / 8.8	8.3 / 8.8
10.1 / 10.6	10.1 / 10.6
9.8 / 10.2	9.8 / 10.2
5.8 / 4.9	5.8 / 4.9
5.8 / 4.9	5.8 / 4.9
5.9 / 5.1	5.9 / 5.1
6.0 / 5.4	6.0 / 5.4
10	10
90	90
30	30
17	17
1	1
345	460
25.4	25.4
110	110
40	40
0.9	0.9
92	92
50	50
26.1	34.8
4	4
0 ; + 50	0 ; + 50
211	249

18 - TECHNICAL FEATURES

18.2 - TECHNICAL FEATURES AGUADENS

TECHNICAL FEATURES AGUADENS		UM	70T	140T
Destination country			UK; IE	UK; IE
Type (Flue exhaust/air intake type)			B23; C43 ; C53 ; C63; C83	
Category			I12H3P	I12H3P
CE-type Certificate (PIN)			0476CR1272	0476CR1272
Maximum input heat		kW	69.9	140.0
Minimum input heat		kW	14.7	14.7
Maximum output (80/60) "P"		kW	67.9	135.8
Efficiency at 100% load (80/60)		%	97	97
Minimum output (80/60)		kW	14.1	14.1
Efficiency at minimum output (80/60)		%	96	96
Maximum output (50/30)		kW	74.0	148.0
Efficiency at maximum output (50/30)		%	106	106
Minimum output (50/30)		kW	15.6	15.6
Efficiency at minimum output (50/30)		%	106	106
Chimney loss burner on (80/60)		%	1	1
Chimney loss burner on at minimum output heat		%	0.5	0.5
Chimney loss burner off		%	0.1	0.1
Casing loss burner on		%	0.1	0.1
Casing loss burner off		%	0.05	0.05
Loss at no load		%	0.05	0.05
Gas flow rate	G20	m³/h	7.40	14.80
	G25	m³/h	8.61	17.22
	G30	kg/h	5.52	11.03
	G31	kg/h	5.43	10.87
Gas supply pressure	G20	mbar	20	20
	G25	mbar	25	25
	G30	mbar	30	30
	G31	mbar	37	37
Gas supply minimum pressure	G20	mbar	10	10
	G25	mbar	10	10
	G30	mbar	10	10
	G31	mbar	10	10
Gas supply maximum pressure	G20	mbar	45	45
	G25	mbar	45	45
	G30	mbar	45	45
	G31	mbar	45	45
Main exchanger water content		lt	7.57	15.14
Minimum operating water flow rate with motorised valve		l/h	1620	1620
Minimum operating water flow rate without motorised valve		l/h	1620	3240
Instantaneous d.h.w. production (dt 30°C)		l/min	33.4	69.6
D.H.W. adjustment range		°C	20 - 80	20 - 80
Maximum temperature for safety intervention		°C	95	95

18 - TECHNICAL FEATURES

18.2 - TECHNICAL FEATURES AGUADENS

210T	280T
UK; IE	UK; IE
B23; C43 ; C53 ; C63; C83	
I12H3P	I12H3P
0476CR1272	0476CR1272
210.0	280.0
14.7	14.7
203.7	271.6
97	97
14.1	14.1
96	96
222.0	296.0
106	106
15.6	15.6
106	106
1	1
0.5	0.5
0.1	0.1
0.1	0.1
0.05	0.05
0.05	0.05
22.20	29.61
25.83	34.43
16.55	22.06
16.30	21.73
20	20
25	25
30	30
37	37
10	10
10	10
10	10
10	10
45	45
45	45
45	45
45	45
22.71	30.28
1620	1620
4860	6480
104.3	139.1
20 - 80	20 - 80
95	95

18 - TECHNICAL FEATURES

18.2 - TECHNICAL FEATURES AGUADENS

TECHNICAL FEATURES AGUADENS		UM	70T	140T
"PMS" maximum pressure		bar	11	11
Minimum pressure		bar	1	1
Rated power supply voltage		V	230	230
Rated power supply frequency		Hz	50	50
Absorbed electrical power		W	150	300
Degree of electrical protection			IP20	IP20
Burner electrical power		W	150	300
Electrical power absorbed by the pump		W	N.A.	N.A.
Air intake and flue exhaust duct diameter (split)		mm	80	110
Max. flue exhaust duct length (split)		m	10	10
Max. air intake duct length (split)		m	10	10
Equivalent length of one curve		m	4	4
Weighted CO (0% O ₂)	G20	ppm	15	15
Weighted NO _x (0% O ₂) (EN 483 class 5)	G20	ppm	15	15
CO ₂ (%) at minimum / maximum output heat	G20	%	8.5 / 8.7	8.5 / 8.7
	G25	%	8.3 / 8.8	8.3 / 8.8
	G30	%	10.1 / 10.6	10.1 / 10.6
	G31	%	9.8 / 10.2	9.8 / 10.2
O ₂ (%) at minimum / maximum output heat	G20	%	5.8 / 4.9	5.8 / 4.9
	G25	%	5.8 / 4.9	5.8 / 4.9
	G30	%	5.9 / 5.1	5.9 / 5.1
	G31	%	6.0 / 5.4	6.0 / 5.4
Maximum flue gas recirculation in case of wind		%	10	10
Maximum flue gas temperature at appliance outlet		°C	90	90
Minimum flue gas temperature at appliance outlet		°C	30	30
Δt temperature fumes/Return (at 100% of the load) (80/60)		°C	17	17
Δt temperature fumes/Return (at 30% of the load) (37/30)		°C	1	1
Flue gas mass flow rate		kg/h	115	230
Flue gas mass flow rate at minimum output heat		kg/h	25.4	25.4
Head available at exhaust		Pa	110	110
Maximum combustion air temperature		°C	40	40
Maximum CO ₂ content in combustion air		%	0.9	0.9
Maximum over-heating flue gas temperature		°C	92	92
Max. admissible vacuum in the flue exhaust/intake system		Pa	50	50
Maximum condensate flow rate		l/h	8.7	17.4
Condensate average degree of acidity		PH	4	4
Operating ambient temperature		°C	0 ; + 50	0 ; + 50
Boiler weight (empty)		kg	98	147

18 - TECHNICAL FEATURES

18.2 - TECHNICAL FEATURES AGUADENS

210T	280T
11	11
1	1
230	230
50	50
430	590
IP20	IP20
430	591
N.A.	N.A.
160	160
10	10
10	10
4	4
15	15
15	15
8.5 / 8.7	8.5 / 8.7
8.3 / 8.8	8.3 / 8.8
10.1 / 10.6	10.1 / 10.6
9.8 / 10.2	9.8 / 10.2
5.8 / 4.9	5.8 / 4.9
5.8 / 4.9	5.8 / 4.9
5.9 / 5.1	5.9 / 5.1
6.0 / 5.4	6.0 / 5.4
10	10
90	90
30	30
17	17
1	1
345	460
25.4	25.4
110	110
40	40
0.9	0.9
92	92
50	50
26.1	34.8
4	4
0 ; + 50	0 ; + 50
211	249

19 - FORCED MENU

Ref.	Parameter description	Adjustment range	Default value	Boiler parameters		
				Individual burner (mod. 70T)	Burner 1 (Master) (mod. 140T, 210T and 280T)	Burners from 2 to 4 (mod. 140T, 210T and 280T)
3001	Burner operation address	0 = Not in cascade 1 = Burner 1 (Master), 2 to 4 = Burner from 2 to 4 (slave burners)	2	0	1	from 2 to 4
3002	Fan adjustment range	from 0 to 4	0	70 = 2	140, 210 and 280 = 2	
3003	Display unit of measurement	C = °C and bar; F = °F and PSI;	C	C	C	C
3004	Water pressure switch	0 = Disabled; 1 = Enabled; 2 = N/A; 3 = N/A	1	1	1	0
3005	Burner flapper valve	0 = Disabled; 4 = Enabled; 8 = N/A; 12 = N/A	4	0	4	4
3006	Water flow rate sensor	0 = Disabled; 16 = N/A; 32 = N/A; 48 = Enabled	48	48	48	48
3007	Condensate level sensor	EnAb = Enabled; dISA = Disabled	Enab	Enab	Enab	dISA
3008	Combustion gas sensor type	SEnS = Sensor; StCH = Switch	SEnS	SEnS	SEnS	SEnS
3009	External sensor type	10 = 10kohms; 12 = 12kohms;	10	10	10	10
3010	Other sensor type	10 = 10kohms; 12 = 12kohms;	10	10	10	10
3011	pump mode	0 = main c pump; 1 = N/A; 2 = N/A; 3 = N/A;	0	0	0	0
3012	domestic hot water operating mode	0 = only heating; 1 = hot water storage tank; 2 = storage tank with thermostat; 3 = N/A; 4 = N/A; 5 = N/A	0	0 = only heating; 1 = hot water storage tank;	0 = only heating; 1 = hot water storage tank;	0
3013	Reset Err 115	EnAb = Enabled; dISA = Disabled	Enab	Enab	Enab	Enab
3015	Climatic adjustment: heating supply maximum temperature (this parameter is overridden by parameter 3017)	from 20°C to 90°C	82°C	82°C	82°C	82°C
3016	Climatic adjustment: heating supply minimum temperature	from 20°C to 90°C	20°C	20°C	20°C	20°C
3017	Supply maximum temperature (this parameter takes priority over parameter 3015)	from 20°C to 90°C	82°C	82°C	82°C	82°C
3018	Minimum supply temperature	from 20°C to 90°C	32°C	32°C	32°C	32°C
3020	Water flow rate sensor type	0 = N/A; 1 = DN8; 2 = DN 10; 3 = DN 15; 4 = DN 20; 5 = DN 25	3	4	4	4
3022	Water minimum pressure	from 0 to 5 bar	1	1	1	1
3035	Minimum water flow rate	from 0 to 100 l/min	27	27	27	27
3050	Slave burner number	from 0 to 3	3	3	140 = 1 210 = 2 280 = 3	3
3085	Modbus address	0 to 126	1	1	1	1
3086	Number of Stopbits	1 or 2	1	1	1	1
3100	Material selection	ABS; CPVC; PVC; SST; PP.	PVC	PVC	PVC	PVC
3101	Nation Selection	US, CA	US	US	US	US
Switch "S4"	Switch "S4" position (see fig 17-11 and 17-12)	On or Off	On	On	On	Off

N/A = Not Applicable

19 - FORCED MENU

Water heater parameters			
Individual burner (mod. 70T)	Burner 1 (Master) (mod. 140T, 210T and 280T)	Burners from 2 to 4 (mod. 140T, 210T and 280T)	Customised values
0	1	from 2 to 4	
70 = 2	140, 210 and 280 = 2		
C	C	C	
1	1	0	
0	4	4	
48	48	48	
Enab	Enab	dISA	
SEnS	SEnS	SEnS	
10	10	10	
10	10	10	
0	0	0	
0 = only heating; 1 = hot water storage tank;	0 for instantaneous domestic hot water; 1 per hot water storage tank.	0	
Enab	Enab	Enab	
N/A	N/A	N/A	
N/A	N/A	N/A	
82°C	82°C	82°C	
32°C	32°C	32°C	
4	4	4	
1	1	1	
27	27	27	
3	140 = 1 210 = 2 280 = 3	3	
1	1	1	
1	1	1	
PVC	PVC	PVC	
US	US	US	
On	On	Off	



ATTENTION!!! Editing these parameters could cause the appliance and, therefore, the system to malfunction. Adjustment of these parameters should only be carried out by a competent person after consideration is given to the potential side-effects that may occur.



ATTENTION!!! Adjustment of parameters within the Forced Menu may cause the system to start without warning. Ensure that the system is in a safe condition before making and changes to avoid damage or injury.



ATTENTION!!! In the event of the multi-burner appliances (140T to 280T models), the display is always connected to burner 1 (MASTER). To set the parameters in the other burners, the display must be connected to them as described in section 17.8



The forced menu allows the appliance to be set based on the system to serve. Setting occurs by adjusting the available parameters (shown in the table).





To access the forced menu, proceed as follows:

1.- Power off the appliance by turning the main switch to the OFF position;

2.- Holding down the RESET and  = keys at the same time, turn the main switch to the ON position;

3.- Wait for the word "INIT" or the 3000 parameters to appear on the display.

4.- Using the  + and  = keys, scroll through the list of 3000 parameters;

5.- Navigate the menu using the  + and  = keys. Once you have selected the parameter, press the RESET key to make it editable via the  + and  = keys;











6.- Press the RESET key to save the changes;

7.- Wait 10 seconds;

8.- Power off the appliance;

9.- Repower the appliance to exit the forced menu and go back to its normal operation.

20 - CONTROL MENU DIAGRAM

Symbol	Description
RESET 0 	Press and release the RESET key
RESET 2 	Hold down the reset key for 2 seconds
RESET 5 	Hold down the reset key for 5 seconds
RESET  5  -	Hold down at the same time for a time in seconds, indicated by the number, the RESET and keys  -
 -	Press and release the key  -
 +	Press and release the key  +

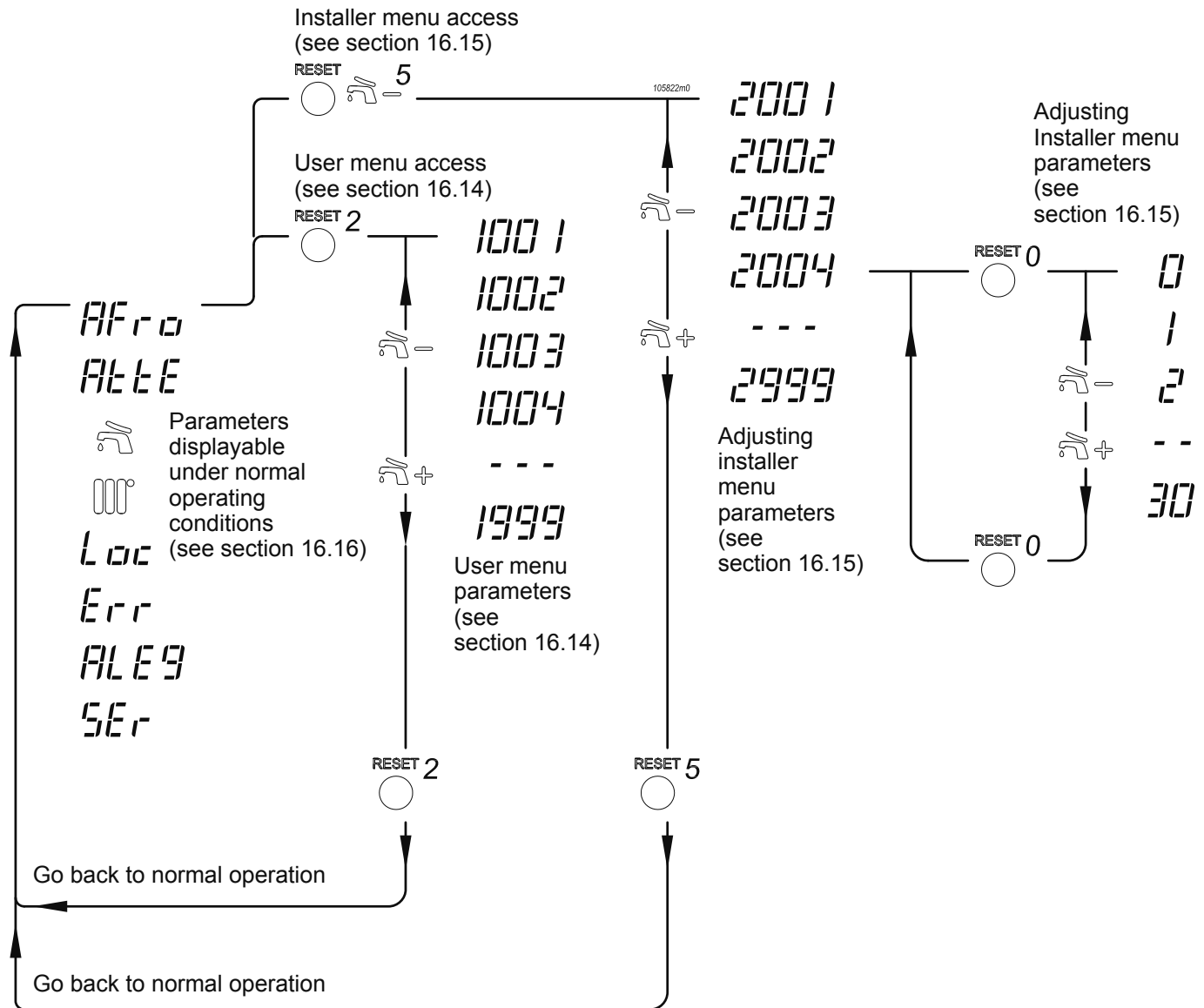
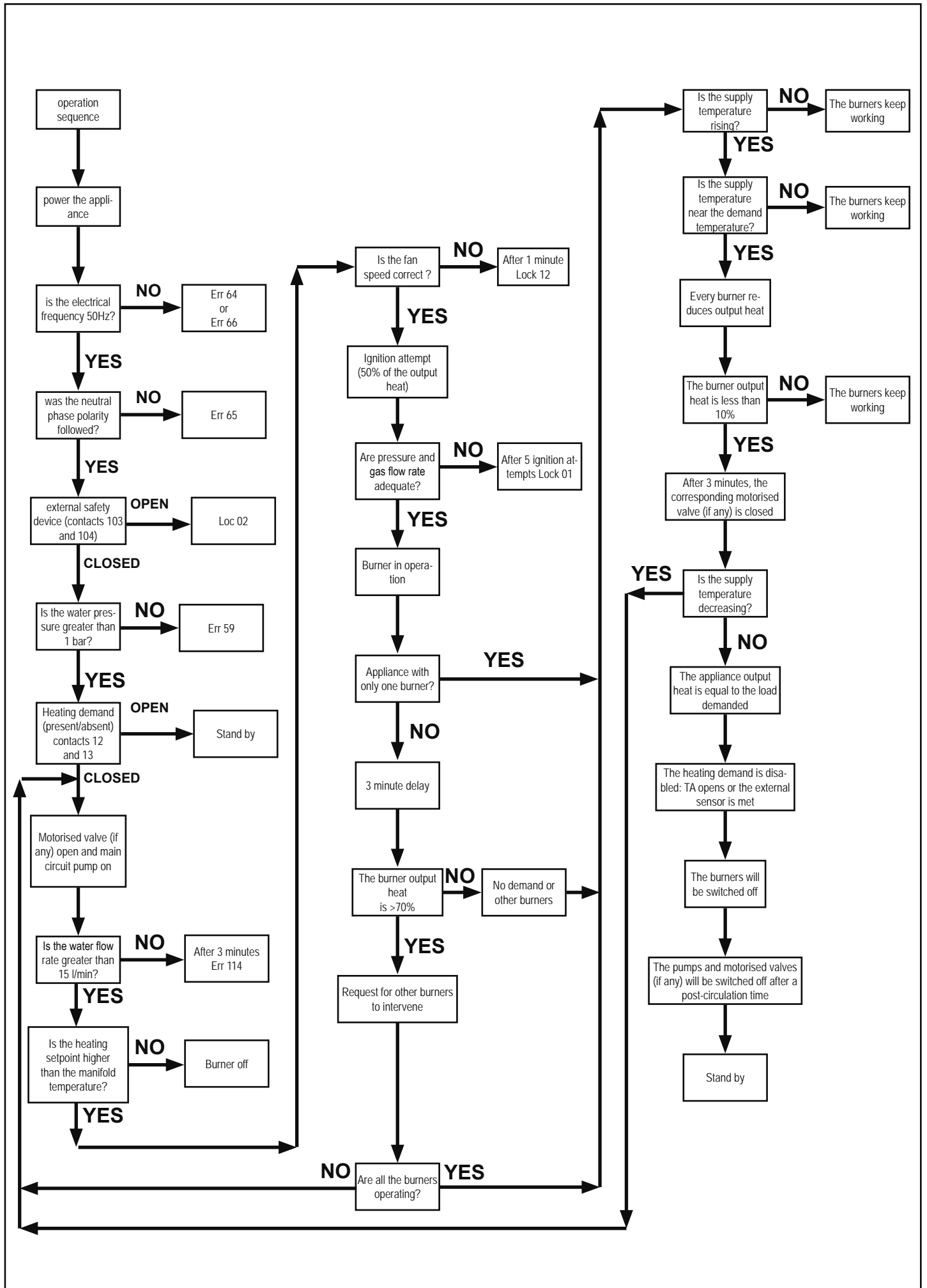
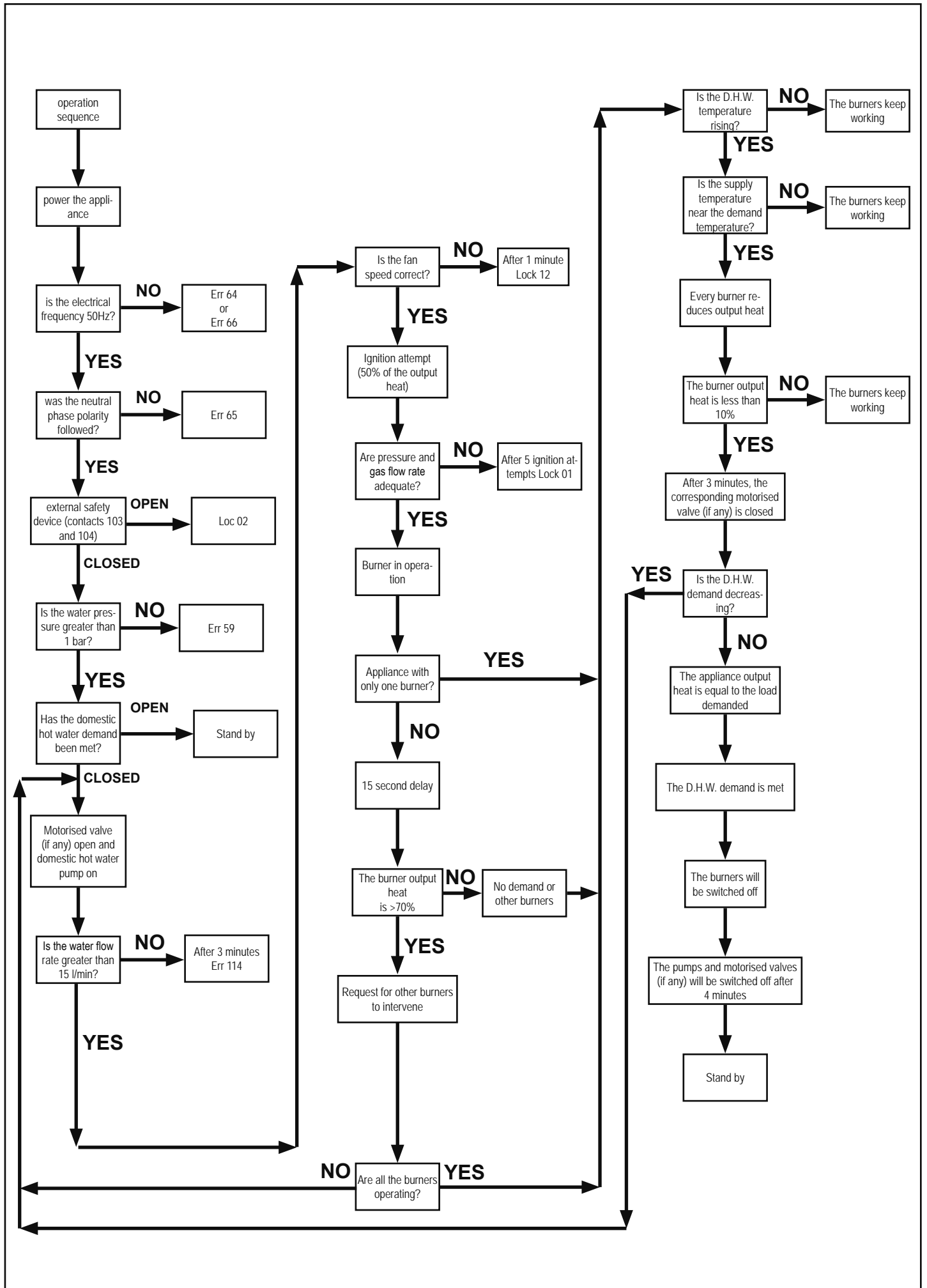

Figure 20-1 - Command menu diagram

21 - BOILER OPERATION SEQUENCE



22 - WATER HEATER OPERATION SEQUENCE



The undersigned company, **CSOSMOGAS S.r.L.**, with registered office in via L. Da Vinci no. 16 - 47014 Meldola (FC) ITALY,

DECLARES

under its own responsibility that the product:

SERIAL NO.	-----
MODEL	-----
MANUFACTURE	-----

subject of this declaration, is compliant with the model described in the **CE** type Test Certificate, issued by the notified body Kiwa Cermet Italia S.p.A., whose references are shown in the table in the TECHNICAL FEATURES section under “CE-type certificate (PIN)” and fulfils the requirements of the following Directives: Gas Appliances, (**2009/142/EC**), Performance, (**92/42/EEC** modified by **EU Reg. 813/2013**), Low Voltage, (**2014/35/EU**), Electromagnetic Compatibility, (**2014/30/EU**).

Product surveillance is done by the notified body according to form “C”.

(The warranty number is the same as the serial number)

This declaration is issued as established by the aforementioned Directives.

Meldola (CFC) ITALY, (Date of manufacture).



Arturo Alessandrini
Sole Project Manager

24 - ErP PRODUCT FICHE MYDENS

The name or brand of the supplier			ADVECO
Reference of the model given by the supplier			MYDENS
			70T
Condensing boiler			YES
Low temperature boiler			NO
B1 Boiler type			NO
Cogeneration space heater			NO
Combination heater			NO
Equipped with supplementary heater			NO
Water heating energy efficiency class			A
Item	Symbol	Unit	
Rated heat output	Pn	kW	68
Seasonal space heating energy efficiency	η_s	%	91
Useful heat output at rated heat output and high-temperature regime (*)	P4	kW	67.9
Useful efficiency at rated heat output and high-temperature regime (*)	η_4	%	87.3
Useful heat output at 30 % of rated heat output and low-temperature regime (**)	P1	kW	20.4
Useful efficiency at 30 % of rated heat output and low-temperature regime (**)	η_1	%	95.8

Auxiliary electricity consumption

At full load	elmax	kW	0.14
At part load	elmin	kW	0.06
In standby mode	Psb	kW	0.005

Other items

Standby heat loss	Pstby	kW	0.1
Ignition burner power consumption	Pign	kW	0
Annual energy consumption	QHE	GJ	130
Sound power level, indoors	LWA	dB	70
Emissions of nitrogen oxides	NOx	mg/kWh	20

For combination heaters

Declared load profile			N/A
Water heating energy efficiency	η_{wh}	%	N/A
Daily electricity consumption	Qelec	kWh	N/A
Annual electricity consumption	AEC	kWh	N/A
Daily fuel consumption	Qfuel	kWh	N/A
Annual fuel consumption	AFC	GJ	N/A

According commission delegated regulation (EU) No 811/2013 and No 813/2013.

N/A = Not applicable.

(*) High-temperature regime means 60 °C return temperature at heater inlet and 80 °C feed temperature at heater outlet.

(**) Low temperature means for condensing boilers 30 °C, for low-temperature boilers 37 °C and for other heaters 50 °C return temperature (at heater inlet).

24 - ErP PRODUCT FICHE MYDENS

ADVECO		
MYDENS		
140T	210T	280T
YES	YES	YES
NO	NO	NO
NO	NO	NO
NO	NO	NO
NO	NO	NO
NO	NO	NO
-	-	-

136	204	272
91	91	91
135.8	203.7	271.6
87.3	87.3	87.3
40.7	61.1	81.5
95.8	95.8	95.8

0.28	0.42	0.56
0.06	0.06	0.06
0.01	0.015	0.02

0.2	0.3	0.4
0	0	0
237	345	452
70	70	70
20	20	20

N/A	N/A	N/A
N/A	N/A	N/A
N/A	N/A	N/A
N/A	N/A	N/A
N/A	N/A	N/A
N/A	N/A	N/A

25 - ErP PRODUCT FICHE AGUADENS

(a) Supplier's name or trade mark			ADVECO
(b) Supplier's model identifier			AGUADENS
			70T
(c) Load profile			XXL (1)
(d) Water heating energy efficiency class			A
(e) Water heating energy efficiency	η_{wh}	%	85.6
(f) Daily electricity consumption	Qelec	kWh	0.19
(f) Annual electricity consumption	AEC	kWh	42
(f) Daily fuel consumption	Qfuel	kWh	28.172
(f) Annual fuel consumption	AFC	GJ	22
(g) Other load profiles			-
(g) Water heating energy efficiency *		%	-
(g) Daily electricity consumption *		kWh	-
(g) Annual electricity consumption *		kWh	-
(g) Daily fuel consumption *		kWh	-
(g) Annual fuel consumption *		GJ	-
(h) Thermostat temperature settings of the water heater		°C	60
(i) Sound power level indoors	LWA	dB	70
(j) The water heater is able to work only during off-peak hours			NO
(k) Any specific precautions that shall be taken when the water heater is assembled, installed or maintained.			Read the installation, use and maintenance manual of the water heater.
(l) Smart control			N/A
Emissions of nitrogen oxides	NOx	mg/kWh	20

According commission delegated regulation (EU) No 812/2013 and No 814/2013;

- (1) with tank AGUATANK 150;
- (2) with tank AGUATANK 300;
- (3) with tank AGUATANK 750;

* refers to other load profiles (g);

N/A = Not applicable;

25 - ErP PRODUCT FICHE AGUADENS

ADVECO		
AGUADENS		
140T	210T	280T
3XL (2)	4XL (3)	4XL (3)
-	-	-
83.1	83.5	83.2
0.36	0.51	0.54
79	112	118
55.356	110.778	111.111
44	88	88
-	-	-
-	-	-
-	-	-
-	-	-
-	-	-
-	-	-
60	60	60
70	70	70
NO	NO	NO
Read the installation, use and maintenance manual of the water heater.		
N/A	N/A	N/A
20	20	20

To contact technical support



Unit 7&8 Armstrong Mall, Southwood Business Park
Farnborough, Hampshire GU14 0NR

PHONE 01252 551 540
enquiries@adveco.co
www.adveco.co