

# Adveco AD Water Heaters

## Instantaneous Water Heaters from 70 to 280 kW



The Adveco AD is a range of floor standing, high-efficiency condensing water heaters designed to provide a reliable, high capacity and semi-instantaneous solution to a building's domestic hot water requirements.

Manufactured by our European partner with over 50 years of industry experience, the AD range consists of four floor standing condensing water heaters with net heat inputs from 70 to 280 kW. Each appliance from 140 kW and above features inbuilt redundancy due to multiple integrated heat exchangers, each constructed from a continuous run of titanium-stabilised stainless steel for added strength and corrosion resistance. Its efficient 3-pass design is unique to the brand and uses large bore, circular cross sections to reduce scale formation.

With very low NO<sub>x</sub> and CO emissions due to an efficient pre-mix burner, as well as a high modulation ratio, the Adveco AD range serves as an environmentally-friendly water heater ideal for applications with large domestic hot water demands, including hotels, schools, and sports centres.

The AD range can be configured to operate in a cascade of up to 8 water heaters using an inbuilt controller that additionally provides full temperature control and self-check maintenance functions. The controller accommodates 0-10 input, MODBUS communication, and alarm output for seamless system integration.

### STANDARD FEATURES

- High capacity semi-instantaneous production of domestic hot water
- Extremely high quality AISI 316Ti heat exchangers with 5 year warranty ensures lasting reliability and efficiency
- Built-in redundancy due to multiple heat engines for AD 140T, 210T, and 280T.
- High efficiency pre-mix burner with 10 year warranty provides large modulation range
- Compact floor standing arrangement
- High maximum run pressure up to 11 bar
- Low emissions, NO<sub>x</sub> class 6 appliance at 27 mg/kWh
- Available for natural gas or LPG
- Acid condensate neutraliser included
- Flue gas non-return valve for overpressure cascade flue systems
- Standard flue systems using low cost 110-160 mm diameter PP

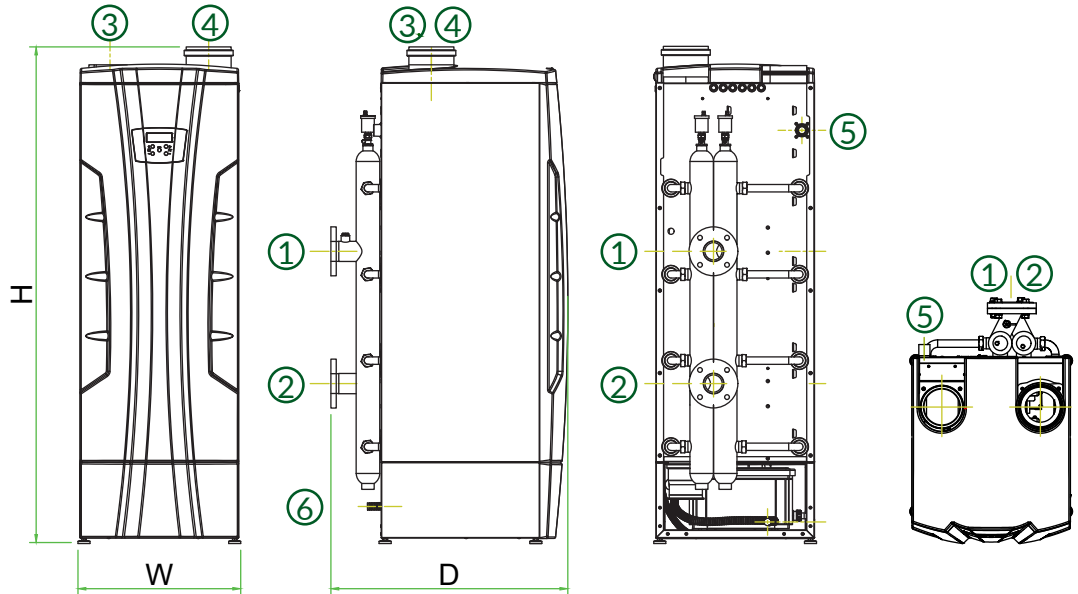

### Dimensions

Model	H x W x D (mm)
AD 70T AD 140T	1180 x 600 x 945
AD 210T AD 280T	1880 x 600 x 896

### Connections

Port	Purpose	AD 70T	AD 140T	AD 210T	AD 280T
1	Hot outlet	1 ½ "	1 ½ "	DN65 PN16	DN65 PN16
2	Cold feed	1 ½ "	1 ½ "	DN65 PN16	DN65 PN16
3	Air intake	n/a	n/a	n/a	n/a
4	Flue exhaust	Ø110 mm	Ø110 mm	Ø160 mm	Ø160 mm
5	Gas inlet	1 "	1 "	1 ¼ "	1 ¼ "
6	Condensate hose	Ø28 mm	Ø28 mm	Ø28 mm	Ø28 mm

### Technical Specifications

Technical Specifications		Units	AD 70T	AD 140T	AD 210T	AD 280T
Gross heat input range	Maximum	kW	77.6	155.4	233.1	310.8
	Minimum		16.3	16.3	16.3	16.3
Heat output range	Maximum	kW	74.0	148.0	222.0	296.0
	Minimum		15.6	15.6	15.6	15.6
Maximum efficiency (net)	At max. output	%	106.0	106.0	106.0	106.0
	At min. output		106.0	106.0	106.0	106.0
DHW Recovery (ΔT 50°C)		l / h	1202	2506	3755	5008
Minimum operating water flow rate		l / s	0.45	0.90	1.35	1.80
Gas flow rate	Natural gas	m <sup>3</sup> /h kg/h	7.40 5.43	14.80 10.87	22.20 16.30	29.61 21.73
	LPG					
Heat exchanger water capacity		l	7.57	15.14	22.71	30.28
DHW temperature range		°C	20 - 80	20 - 80	20 - 80	20 - 80
System pressure range		bar	1 - 11	1 - 11	1 - 11	1 - 11
Supply		V / Hz	230 / 50	230 / 50	230 / 50	230 / 50
Electrical consumption	Maximum	W	140	280	420	560
	Minimum		60	60	60	60
CO emissions		ppm	15	15	15	15
NO <sub>x</sub> emissions (0% O <sub>2</sub> with natural gas)		mg/kWh	27	27	27	27
Approved flue types			B23	B23	B23	B23
Flue gas mass flow rate		kg/h	115	230	345	460
Flue gas temperature at outlet	Maximum	°C	90	90	90	90
	Minimum		30	30	30	30
Sound power level (LWA)		dB	70	70	70	70
Appliance Mass	Empty	kg	98	147	211	249
	Full		106	162	234	279

## AD Example Installation Schematic

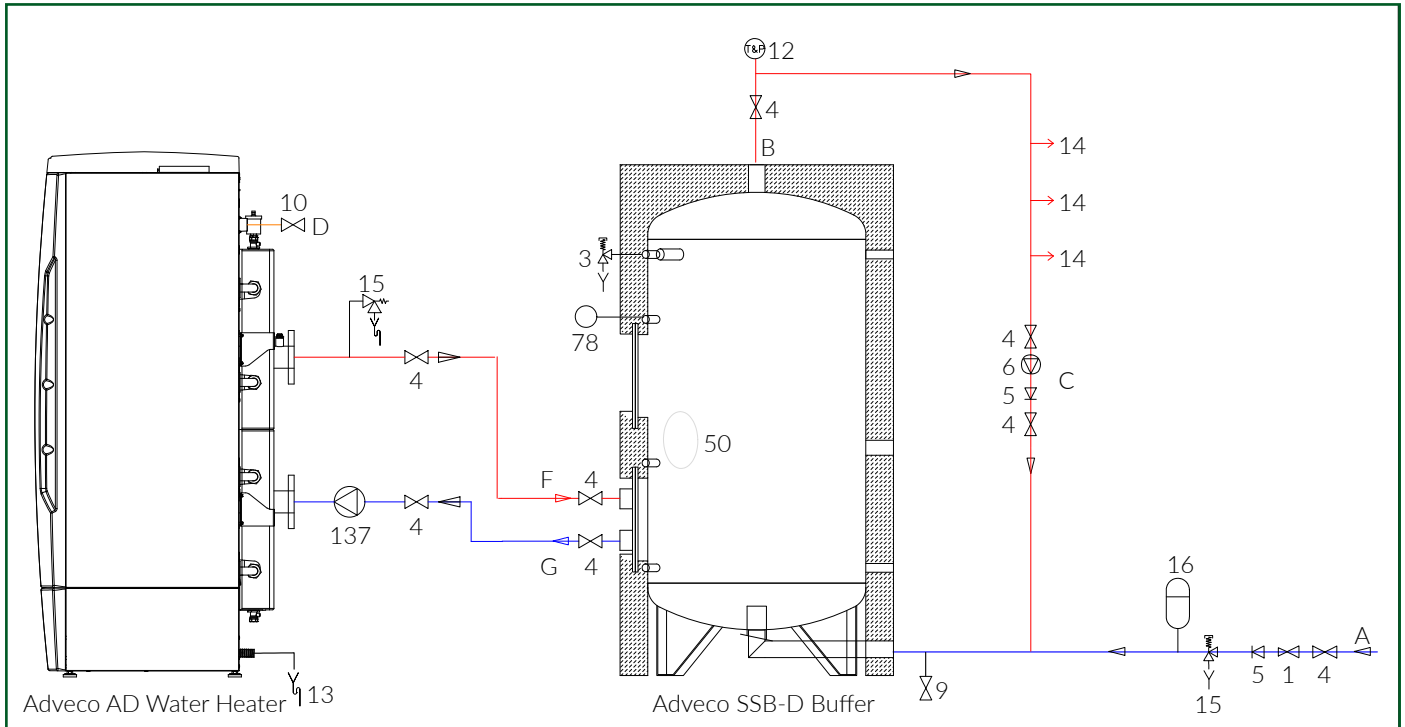

### Legend

A	Mains Cold Water Feed	9	Drain Valve
B	Hot Water Flow	10	Gas Isolation Valve
C	Hot Water Return	12	Temperature and Pressure Gauge
D	Gas Supply	13	Condensate Drain
F	Water Heater Flow	14	Hot Water Outlets
G	Water Heater Return	15	Expansion Relief Valve
1	Pressure Limiting Valve / Strainer	16	Cold Feed Expansion Vessel
3	Thermal & Pressure Relief Valve and Tundish	50	Optional Immersion Heater Backup
4	Isolation Valve	78	High Limit Thermostat
5	Check Valve	137	Water Heater Feed Circulation Pump
6	Secondary Return Circulation Pump		

Water Heater Pumps And Water Hardness	Soft < 192 ppm	Medium 193 ≤ 278 ppm	Hard 279 ≤ 335* ppm
AD 70T	M0137	M0138	M0142
AD 140T	M0138	M0140	M0141
AD 210T	M0139	M0141	M0143
AD 280T	M0139	M0141	M0143

\* If the water supply has a total hardness greater than 335 ppm, it is recommended to soften the water.

Standard Flue	Size:	110mm PP	160mm PP	200mm PP
Suitable for		AD 70T AD 140T	AD 140T* AD 210T AD 280T	AD 210T* AD 280T*
*: Requires adaptor		80-110mm: 200050660085	110-160mm: 0718025	160-200mm: 071823

#### Flue Terminals



Vertical:	MB0025	0718761	0718762
Horizontal:	MB0028	100035790094	100035790004

#### Flue Extension 1m



	0718102	0718122	0718132
--	---------	---------	---------

#### Flue Bends



45° Bend:	0718140	0718160	0718170
90° Bend:	0718141	0718161	0718171

#### Roof Flashings

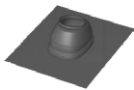

Flat:	0146184	0746066	0146185
15-55° Pitched:	MB0033	100035790099	100035790003

#### Flue Bracket



	0169158	100035790092	200050718012
--	---------	--------------	--------------

External flue	size:	110/160mm PP/SS	160mm/225mm PP/SS	200mm/300mm PP/SS
Suitable for:		AD 70T AD 140T	AD 140T* AD 210T AD 280T	AD 210T* AD 280T*
*: Requires adaptor:		80-110mm: 200050660085	110-160mm: 0718025	M/F 160-200mm: 071823

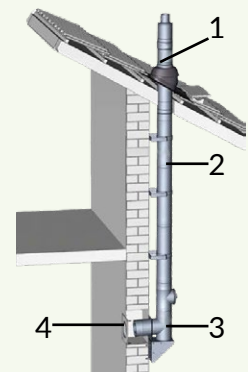

1, 3, 4 - External Riser Kit:	MB0026	MB0029	MB0031
2 - 1m Extension Kit:	MB0027	MB0030	MB0032
45° External Bend:	n/a	200075045316	200075045916
90° External Bend:	n/a	200075045326	200075045926