

INSTALLATION, USE AND MAINTENANCE MANUAL

GAS CONDENSING
FREE-STANDING BOILER

MYDENS

GAS CONDENSING
FREE-STANDING HOT WATER HEATER

AGUADENS

70T
140T
210T
280T



WARNING!!!

FAILURE TO COMPLY WITH THESE PROVISIONS AND REQUIREMENTS MAY COMPROMISE THE SAFETY OF THE UNIT AND CAN RESULT IN A FIRE OR EXPLOSION CAUSING PROPERTY DAMAGE, PERSONAL INJURY, OR DEATH.

Installer: Read all instructions, including this manual, before installing. Perform steps in the order given.

User: This manual is for use only by a qualified heating installer. Refer to the User's Information section for your reference.

Maintenance: at least once a year the user must call a **Competent Person** for routine maintenance.

If you smell gas

- A - Turn off the gas supply at the gas meter;
- B - Extinguish all naked flames – do not smoke or strike matches;
- C - Do not operate electrical appliances or switches such as a light switch.
- D - Open all doors and windows to ventilate the property.
- E - Call the gas emergency service and follow their directions.

Carbon Monoxide.

Every year deaths and serious injuries occur due to carbon monoxide poisoning. These tragedies are avoidable if certain preventative measures such as the following are undertaken:

- ☞ Ensure that all boilers, water heaters, room heaters, stoves and hobs which burn oil, natural gas, LP gas, coal, peat, wood and wood pellets are serviced regularly. Servicing is needed at least once per year to ensure safety. The service person should be qualified and trained to service the specific types of appliance
- ☞ If an appliance is fitted in a dwelling, then a carbon monoxide detector should always be fitted. There are two types available: a simple detector works like a fire alarm to emit a loud noise and flashing light if carbon monoxide is detected or a more sophisticated version which will also switch off the appliance to provide more safety.

Explosive or highly flammable products

Do not store or use explosive or highly flammable materials such as paper, solvents, paints, etc...in the same room where the appliance is installed.

If you can smell combustion products

1. - Switch the appliance off.
2. - Ventilate the room.
3. - Call a professionally qualified technician.

Competent Person: Competent Person is an individual with specific, technical training in space heating systems, domestic hot water systems, fuel gas systems and electrical systems. This individual must have the legally required qualifications.

Installation and Modifications: Only a Competent Person must carry out the installation and calibration of the heater. Never modify the heater or its flue gas carrying components in any way. This heater must be properly vented.

Flue gas/air intake:

- You are only permitted to operate this appliance with the combustion air/flue gas system that has been specifically designed and approved.
- Do not obstruct the air intake or vent pipe terminals.
- If heater installation is provided as replacement heater, DO NOT connect new heater to an existing flue system, unless the flue system designer has been consulted.
- Do not restrict or seal any air intake or outlet openings (terminals).

Hazards and Your Safety - Hot Water Can Scald! Water temperature over 52°C can cause severe burns instantly, or death from scalds. Children, the disabled, and the elderly are at highest risk of being scalded; see instruction manual before setting temperature at heater! Feel water before bathing or showering.

Defects: If you find any defects, you must inform the owner of the system of the defect and the associated hazard in writing.

When servicing heater, to avoid electric shock, disconnect electrical supply before performing maintenance.

When servicing heater, to avoid severe burns, allow heater to cool before performing maintenance.

Label all wires prior to disconnection when servicing controls. Wiring errors can cause improper and dangerous operation. Verify proper operation after servicing.

Correct Use:

This heater must only be used for the purpose for which it has been expressly designed: Heating of water for closed circuit systems for central heating.

Do not use this appliance if any part has been under water. Immediately call a competent person to inspect the appliance and to replace any part of the control system and any gas control, which has been under water.

Ensure the heater and its controls are protected from dripping or spraying water during normal operation or service.

Only use the heater in the combinations and with the accessories and spares listed in this manual.

For safety and environmental reasons, the packing materials must be properly disposed of. Any replaced part or packaging should never be left within the reach of children.

CAUTION!!!

FAILURE TO COMPLY WITH THESE PROVISIONS AND REQUIREMENTS MAY COMPROMISE THE SAFETY OF THE UNIT AND CAN RESULT IN A FIRE OR EXPLOSION CAUSING PROPERTY DAMAGE, PERSONAL INJURY, OR DEATH.

Installation location: The heater must be located in an area where leakage of the tank or connections will not result in damage to the area adjacent to the heater or to lower floors of the structure. When such locations cannot be avoided, it is recommended that a suitable drain pan, adequately drained, be installed under the heater. The pan must not restrict combustion air flow.

Installation location: The heater must be installed on a non-combustible surface.

In the event of a breakdown and/or malfunction of the heater, turn off the unit and do not make any attempt to repair it. The heater must be serviced by a Competent Person using original spare parts.

Installation, modifications

- ☞ Seal the adjustment devices after every calibration.
- ☞ In agreement with the provisions for use, the user must keep the installation in good working order and guarantee reliable and safe operation of the appliance.
- ☞ We also highlight the importance of an annual scheduled maintenance contract with a professionally qualified technician.
- ☞ The end user must have maintenance performed on the appliance only by competent person in accordance with this manual and in full compliance with both local and national standards.
- ☞ Before performing any cleaning or maintenance, disconnect the appliance from the mains power supply.
- ☞ After any cleaning or maintenance, before reconnecting the power supply, make sure that all internal parts are properly dry.

☞ This appliance is not intended for use by persons (including children) with reduced physical and sensory conditions or lack of experience and knowledge, unless they have been given supervision or instruction concerning use of the appliance by a person responsible for their safety.

☞ This manual is an integral and essential part of the product and must be kept carefully by the user, for possible future consultation. If the appliance must be transferred or if you should move and leave the unit to another user, always ensure that this manual remains with the new user and/or installer.

Do not use “homemade cures” or “heater patent medicines”. Serious damage to the heater, personnel, and/or property may result.

Do not use petroleum-based cleaning or sealing compounds in the heater system. Gaskets and seals in the system may be damaged. This can result in substantial property damage.

Technical drawings

All drawings in this manual relating to electrical wiring, hydraulic and gas layouts are purely indicative. The external services such as electrical cable types and sizes, water pipes and gas pipes must always be checked by a professionally qualified technician or engineer to verify compliance with all relevant standards, Laws and codes of good practice.

NOTICE!

Local approval of the flue system and the condensate connection to the public sewer system may be required.

The local building regulations stipulating the installation rules at the time of installation.

When calling or writing about the heater – Please have the heater model and serial number from the heater rating plate.

Any claims for damage or shortage in shipment must be filed immediately against the transportation company by the consignee.

The manufacturer declines all liability, contractual or otherwise (warranty included), for any damage to people, animals property or this same appliance, caused by:

- a) - incorrect installation;
- b) - failure to comply with this or any other instruction provided by the manufacturer;
- c) - failure to comply with the applicable local and/or national regulations in force;
- d) - incorrect use of this appliance
- e) - inadequate or incorrect service
- f) - inadequate or incorrect maintenance.

CONTENTS

SAFETY INSTRUCTIONS	2
1 - CODE REQUIREMENTS	7
1.1 - National laws and regulations	7
2 - GENERAL INFORMATION	8
2.1 - Presentation	8
2.2 - Overview of models	8
2.3 - Accessories included	9
2.4 - Manufacturer	9
2.5 - Meaning of symbols used	9
2.6 - Maintenance	9
2.7 - Disposal	9
3 - MAIN COMPONENTS	10
4 - OPERATION	18
4.1 - Operation and intended use	22
4.1.1 - MYDENS boiler operation and intended use	22
4.1.2 - AGUADENS hot water heater operation and intended use	22
4.1.3 - Wide modulation range and maximum efficiency	22
4.1.4 - Primary circuit pump	23
4.1.5 - Central heating circuit pump	23
4.1.6 - Domestic hot water circuit pump	23
4.1.7 - Hydraulic separator	23
4.1.8 - MYDENS boiler production of domestic hot water	23
4.1.9 - Types of system	23
4.2 - Precautions for installation	23
4.3 - Anti-Legionella	23
5 - INSTALLATION - Place of installation	24
5.1 - Selection of place of installation	24
5.1.1 - Requirements for correct ventilation	25
5.1.2 - Preventing contamination of combustion air	25
6 - INSTALLATION - Setup	26
6.1 - Setup	26
6.1.1 - Moving the boiler	26
6.1.2 - Opening the package	26
6.1.3 - Lifting the boiler	26
7 - INSTALLATION - Minimum distances to be observed	27
7.1 - Dimensions and minimum distances to be observed	27
8 - INSTALLATION - Dimensions and centre space distances - MYDENS boiler	28
9 - INSTALLATION - Dimensions and centre space distances - AGUADENS hot water heater	30
10 - INSTALLATION - Plumbing connections - MYDENS boiler	32
10.1 - MYDENS boiler plumbing and gas connections	32
10.2 - MYDENS boiler safety valve (responsibility of the installer)	32
10.3 - Examples of installation of MYDENS boiler	32
10.4 - MYDENS boiler INAIL safety devices	34
10.5 - Connection of expansion tank	35
10.6 - Delivery and return	35
10.7 - MYDENS boiler water supply	35
10.7.1 - Recommendations on characteristics of water in the system	35
10.7.2 - For correct operation of the system make sure that:	35
10.7.3 Water treatment in domestic heating systems	36
10.8 - MYDENS boiler heat circuit outlet	36
10.9 - MYDENS boiler low-temperature systems (or underfloor heating)	36
10.10 - Manifold sensor	36
10.11 - MYDENS boiler characteristic curve of head losses	37
11 - INSTALLATION - Plumbing connections - AGUADENS hot water heater	38
11.1 - AGUADENS hot water heater plumbing and gas connections	38
11.2 - AGUADENS hot water heater safety valve (responsibility of the installer)	38
11.3 - AGUADENS hot water heater examples of installation	38
11.4 - AGUADENS hot water heater INAIL safety devices	39
11.5 - Expansion tank	40
11.6 - Circulation pump	40
11.7 - Size of system	40
11.8 - Precautions against scalds	41

CONTENTS

11.9 - Water quality.....	41
12 - INSTALLATION - Disposal of condensate.....	42
12.1 - Condensate outlet.....	42
13 - INSTALLATION - Electrical connections.....	43
13.1 - Electrical connections: details.....	43
13.1.1 - Connecting power supply cable.....	43
13.1.2 - Choosing the room thermostat/chronothermostat.....	44
13.1.3 - Connecting the room thermostat/chronothermostat.....	44
13.1.4 - Installing the outdoor temperature sensor.....	44
13.1.5 - Connection board 885 IF (on request).....	45
13.1.6 - Alarm contact.....	45
13.2 - Connecting MYDENS boiler to storage tank.....	45
13.2.1 - Precedence to production of DHW.....	45
13.3 - Connecting AGUADENS hot water heater to storage tank.....	46
13.4 - Cascading appliances.....	49
14 - INSTALLATION - Flue gas outlet and air intake pipe.....	50
14.1 - Burned gas exhaust and combustion agent air intake pipe.....	50
14.1.1 - Type of intake/exhaust B23 and B23P.....	50
14.1.2 - Split system.....	51
15 - INSTALLATION - External cover.....	52
15.1 - Installation of external cover for models 70T - 140T.....	52
15.2 - Installation of external cover for models 210T - 280T.....	56
16 - START-UP.....	61
16.1 - Start-up.....	61
16.1.1 - Instructions to the user.....	61
16.1.2 - Filling the condensate outlet siphon.....	61
16.1.3 - Filling the central heating system.....	61
16.2 - General recommendations regarding the gas supply.....	62
16.3 - Type of gas for which the appliance is set.....	62
16.4 - Conversion of boiler models 70T from one type of gas to another.....	63
16.5 - Conversion of boiler models 140T to 280T from one type of gas to another.....	65
16.6 - Ignition.....	67
16.6.1 - MYDENS boiler ignition.....	67
16.6.2 - AGUADENS hot water heater ignition.....	67
16.7 - Controlling the supply gas pressure and any adjustments.....	67
16.8 - Controlling the level of CO ₂ and any adjustments.....	68
16.8.1 - Check the CO ₂ content and make any necessary adjustment on boiler models 70T.....	68
16.8.2 - Check the CO ₂ content and make any necessary adjustment on boiler models 140T to 280T.....	69
16.9 - Check boiler power.....	69
16.10 - Minimum water flow rate.....	69
17 - USE.....	70
17.1 - Water pressure check.....	70
17.1.1 - MYDENS boiler checking water pressure.....	70
17.1.2 - AGUADENS hot water heater checking system pressure.....	70
17.2 - General information.....	71
17.3 - Display.....	71
17.4 - Ignition and switch-off procedure.....	71
17.5 - AGUADENS hot water heater adjusting the temperature.....	71
17.6 - MYDENS boiler adjusting the domestic hot water.....	71
17.7 - MYDENS boiler adjusting the central heating.....	71
17.8 - Thermostatic adjustment of central heating.....	71
17.9 - Climate control.....	72
17.9.1 - Climate control: setting the parameters.....	72
17.9.2 - Climate control: switching the central heating service on and off.....	72
17.10 - Time settings for the various functions.....	72
17.11 - Pump anti-blocking.....	72
17.12 - Anti-freeze protection.....	72
17.13 - Energy Saving.....	72
17.14 - "User menu".....	74
17.15 - "Installer menu".....	75
17.16 - Diagnostics.....	76
17.16.1 - Diagnostics: lockouts "Loc".....	77
17.16.2 - Diagnostics: errors "Err".....	79

CONTENTS

18 - MAINTENANCE	81
18.1 - General recommendations.....	81
18.1.1 - Gas leak check.....	81
18.1.2 - Checking the condition of the air intake and flue exhaust ducts.....	81
18.1.3 - Checking the system water pressure.....	81
18.1.4 - Checking the ignition and detection electrodes.....	81
18.2 - Dismantling of cover and access to internal components.....	82
18.3 - Dismantling the burner fan assembly.....	82
18.4 - Cleaning the burner and the primary heat exchanger, flue gas side.....	83
18.4.1 - Heat insulation devices.....	85
18.5 - Correct positioning of ignition and ionisation electrodes.....	85
18.6 - Cleaning of air intake filter.....	86
18.7 - Maintenance and cleaning of condensate outlet system.....	86
18.8 - Connection of Display to other burners.....	87
18.9 - How to move a control board.....	88
18.10 - Emptying the boiler.....	90
18.11 - Minimum and maximum power.....	90
18.12 - Checking the ionisation current.....	90
18.13 - Checking combustion efficiency.....	90
18.14 - Water temperature measurement sensors.....	91
18.15 - Outdoor temperature sensor.....	91
18.16 - Multi-wire wiring diagram for models 70T.....	92
18.17 - Multi-wire wiring diagram for models 140T, 210T and 280T.....	94
19 - TECHNICAL DATA	98
19.1 - MYDENS TECHNICAL DATA.....	98
19.2 - AGUADENS TECHNICAL DATA.....	102
20 - FORCED MENU	106
21 - COMMAND MENU DIAGRAM	108
22 - BOILER OPERATING SEQUENCE	110
23 - HOT WATER HEATER OPERATING SEQUENCE	111
24 - MYDENS PRODUCT FILE	112
25 - AGUADENS PRODUCT FILE	114
26 - EU DECLARATION OF COMPLIANCE	116

1 - CODE REQUIREMENTS

1.1 - National laws and regulations

- M.D. no.37 dated 22/01/2008 (former Law no.46 dated 05/03/90)
- Law no.10 dated 09/01/91

- Presidential Decree no.412 dated 26/08/93
- Presidential Decree no.551 dated 21/12/99
- Legislative Decree no.192 dated 19/08/05
- Legislative Decree no.311 dated 29.12.06

- UNI 7129 Standard
- UNI 7131 Standard
- UNI 11071 Standard
- IEC 64-8 Standard

All the gas appliances must be installed by a competent and qualified person, in accordance with the relevant clauses of applicable standards and recommendations. These include but may not be limited to the following:

- I.S. 813 Domestic gas installations.
- I.S. 820 Non-Domestic gas installations.
- IEE Wiring Regulations.

- BS 5546:2010 - Specification for installation and maintenance of gas-fired water-heating appliances of rated input not exceeding 70 kW net.

- BS 5440-2:2009 - Flueing and ventilation for gas appliances of rated input not exceeding 70 kW net (1st, 2nd and 3rd family gases) specification for the installation and maintenance of ventilation provision for gas appliances.

- BS 6644:2011 - Specification for the installation and maintenance of gas-fired hot water boilers of rated inputs between 70 kW (net) and 1.8 MW (net) (2nd and 3rd family gases).

- BS 6891:2005+A2:2008 - Installation of low pressure gas pipework of up to 35 mm (R1 1/4) in domestic premises (2nd family gas) specification.

- BS 5482-1:2005 - Code of practice for domestic butane and propane gas burning installations. Installations at permanent dwellings, residential park homes and commercial premises, with installation pipework sizes not exceeding DN 25 for steel and DN 28 for corrugated stainless steel or copper.

- BS 5482-2:AMD 12046: June 2001 - Domestic butane and propane gas burning installations. Installations in caravans and non-permanent dwellings.

- BS 5482-3:2005 - Domestic butane and propane gas burning installations. Installations in boats, yachts and other vessels.

- Building regulations issued by the Department of the Environment and Building Standards Regulations.

- Gas safety (Installation and Use) Regulations current issue.

- BS 6700 - Design, installation, testing and maintenance of services supplying water for domestic use within buildings and their cartilages - Specification.

- UK Health and safety at work Act.

- All relevant Building Regulations.

- Local Water Byelaws.

- Water Regulations.

- Health & Safety legislation.

Failure to install this appliance correctly could lead to prosecution. It is in your own interest and in the interest of safety to ensure that the law is complied with. Manufacturer's instructions must not be interpreted as over-riding statutory obligations under any circumstances.

2.1 - Presentation

Congratulations! You have purchased one of the best products on the market. Each individual part is proudly designed, manufactured, tested and assembled within the COSMOGAS facilities, thus guaranteeing the best quality control.

2.2 - Overview of models

XXXXDENS XXXTXX

v = Appliance with 2-way valves
s = Appliance with stainless steel manifold (*)
sv = Appliance with 2-way valves and stainless steel manifold (*)
c = Appliance with carbon steel manifold
cv = Appliance with 2-way valves and carbon steel manifold

“70T” = Free-standing boiler with maximum heat input of 69.9 kW;
“140T” = Free-standing boiler with maximum heat input of 140 kW;
“210T” = Free-standing boiler with maximum heat input of 210 kW;
“280T” = Free-standing boiler with maximum heat input of 280 kW;









“MYDENS” = Internal gas condensing boiler with premixed burner with low emissions of pollutants.
“AGUADENS” = Internal gas condensing hot water heater with premixed burner with low emissions of pollutants.

(*) The AGUADENS models have a stainless steel manifold fitted as standard.

2 - GENERAL INFORMATION

2.3 - Accessories included

The boiler is supplied with the following accessories:

Quantity No.	Description	Code	Figure
N° 1	GAS CONVERSION KIT MET-LPG 70T, 140T, 210T AND 280T.	62630198	
N° 1	SENSOR 10K D6X45 L=2500 T	62110071	
N° 1	EXTERNAL SENSOR	62110067	
N° 4	ADJUSTABLE FEET	60805006	
N° 1	10KG SACK OF GRANULATE CONDENSATE NEUTRALISER.	62801022	
N° 1	REDUCTION 1P NPT - 1P GAS	Only in models 70T and 140T	
	REDUCTION 1P1/4 NPT - 1P1/4 GAS	Only in models 210T and 280T	
N° 2	REDUCTION 2P NPT - 1P1/2 GAS	Only in models 70T and 140T	
N° 2	FLANGE EN 1092-1-13 DN65 PN16 NPT	Only in models 210T and 280T	

2.4 - Manufacturer

COSMOGAS srl
Via L. da Vinci 16
47014 - Meldola (FC) Italy
Tel. (+39) 0543 498383
Fax. (+39) 0543 498393
www.cosmogas.com
info@cosmogas.com

2.5 - Meaning of symbols used



WARNING!

Danger of electric shocks. If these warnings are not heeded it can jeopardise correct operation of the boiler or cause serious injury or damage to people, animals or things.



WARNING!

Generic danger. Failure to comply with these warnings may jeopardise the working order of the appliance or cause serious damage or injury to persons, animals or things.

 Important indication symbol

2.6 - Maintenance

A regular annual maintenance check on the appliance is advised for the following reasons:

- to maintain high efficiency and reduce fuel consumption;
- to achieve a high level of operating safety;
- to maintain a high level of environmental combustion compatibility;

Offer your customer a scheduled maintenance contract.

2.7 - Disposal



The crossed wheelie bin symbol means that the product must not be thrown away in the ordinary rubbish bin (i.e. in with "mixed urban rubbish"). It must be dealt with separately, in order to undergo suitable operations for it to be reused or treated to remove and safely dispose of any substances that are dangerous for the environment. This will enable all the raw materials to be recycled. The user is responsible for getting rid of the boiler at the end of its life, delivering it to a recycling centre run by the local authority or city hygiene companies, or, when he/she buys a new boiler, giving the product that has been replaced to the dealer, who is obliged to take it under the terms of EU Directive 2012/19/EU.

For further information regarding correct decommissioning of these appliances, users can contact the public service in charge or retailers.

3 - MAIN COMPONENTS

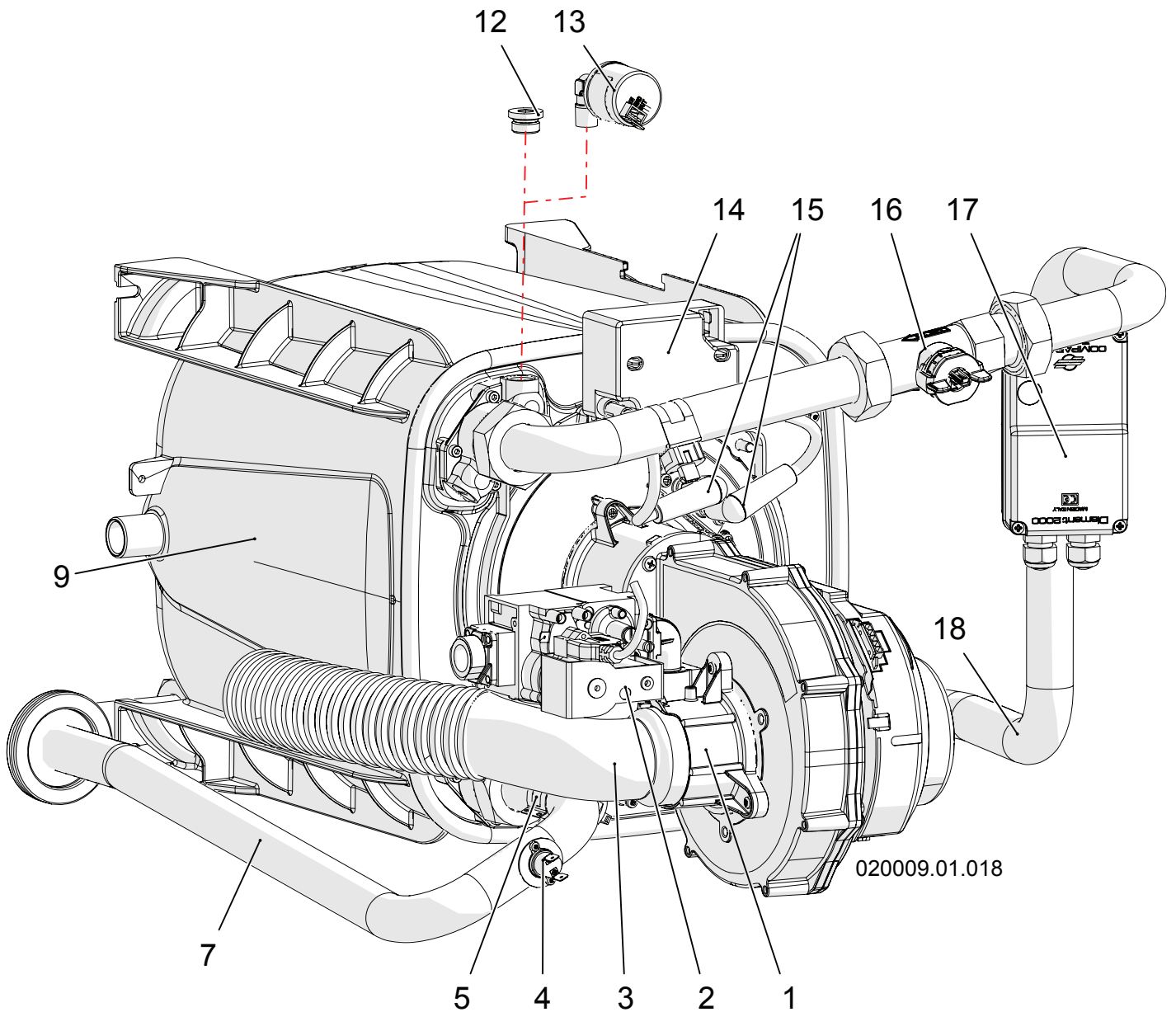

- | | |
|----------------------------------|---|
| 1 - Air/gas mixing group | 11 - ----- |
| 2 - Gas valve | 12 - Stopper (not present) |
| 3 - Air inlet manifold | 13 - Water pressure sensor (present in burner 1 MASTER) |
| 4 - Hot water safety thermostat | 14 - Sparks generator |
| 5 - Hot water temperature sensor | 15 - Ignition cables |
| 6 - ----- | 16 - Water flow rate gauge |
| 7 - Hot water outlet pipe | 17 - 2-way motorised valve (on request) |
| 8 - ----- | 18 - Water inlet pipe |
| 9 - Heat exchanger | 39 - ----- |
| 10 - ----- | |

Figure 3-1 - Internal components

3 - MAIN COMPONENTS

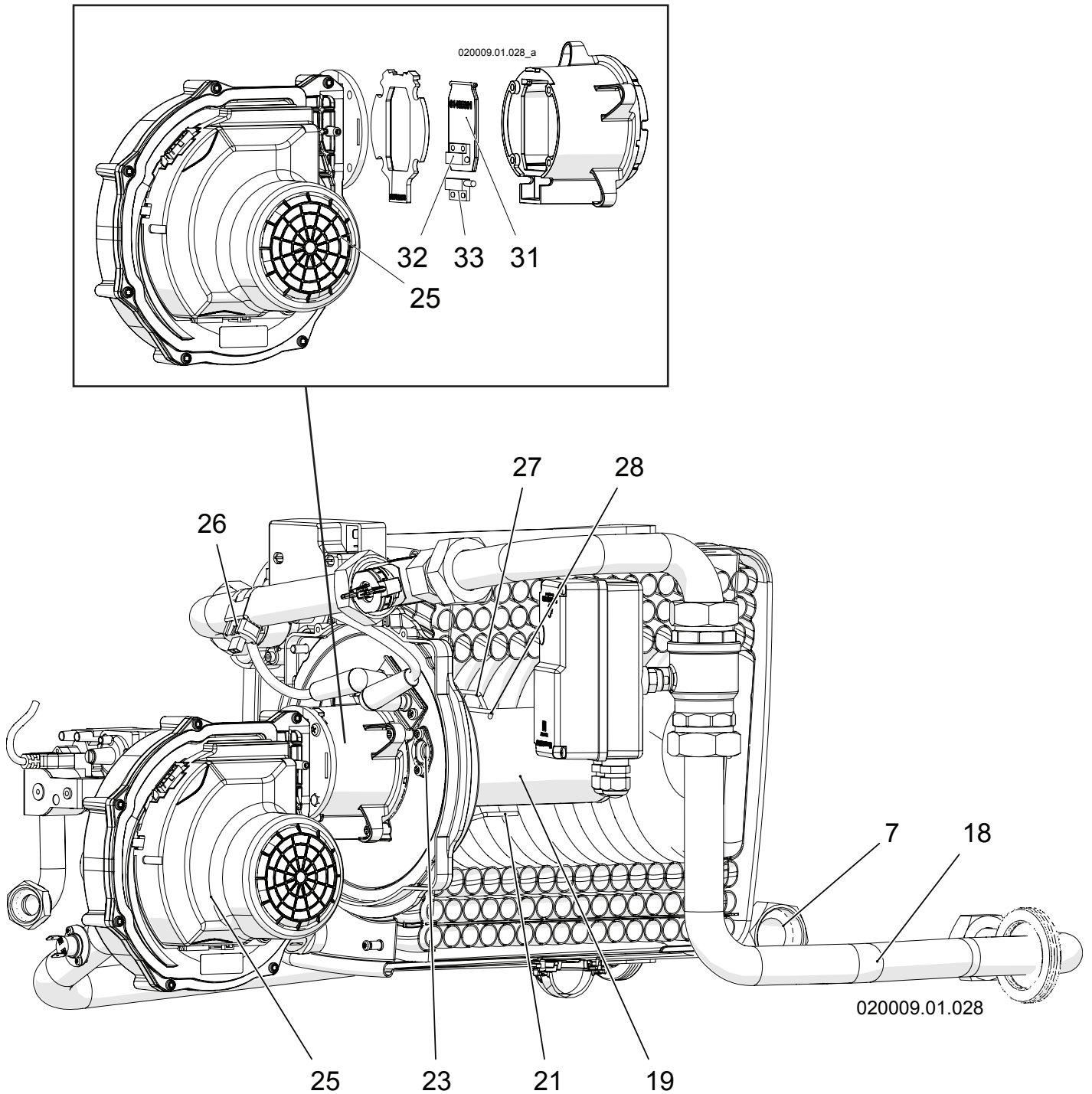

- | | |
|--------------------------|-------------------------------------|
| 19 - Burner | 26 - Water inlet temperature sensor |
| 20 - ----- | 27 - LH ignition electrode |
| 21 - Detection electrode | 28 - RH ignition electrode |
| 22 - ----- | 29 - ----- |
| 23 - Burner pilot light | 30 - ----- |
| 24 - ----- | 31 - Flue gases check valve |
| 25 - Fan | 32 - Check valve magnet |
| | 33 - Check valve sensor |

Figure 3-2 - Internal components

3 - MAIN COMPONENTS

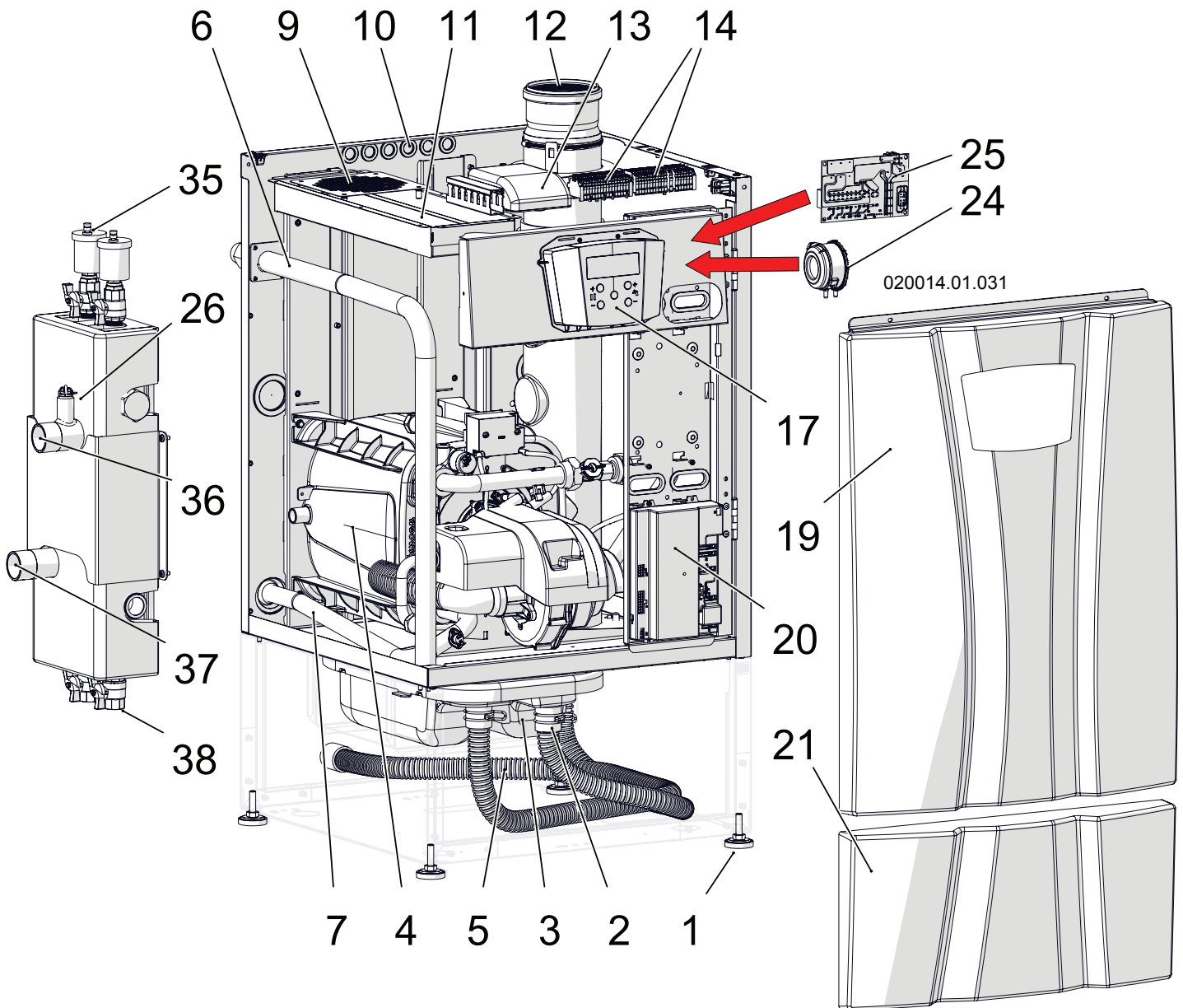

- 1 - Adjustable feet
- 2 - Exhaust gases condensate outlet pipe
- 3 - Condensate neutraliser
- 4 - Burner "1" (MASTER)
- 5 - Condensate outlet pipe
- 6 - Gas inlet pipe
- 7 - Hot water outlet pipe
- 8 - -----
- 9 - Air intake
- 10 - Passage of electrical wires
- 11 - Air intake filter
- 12 - Exhaust gases outlet
- 13 - Board 885 IF (on request)
- 14 - Electrical connections

- 15 - -----
- 16 - -----
- 17 - Control panel
- 18 - -----
- 19 - Top front casing
- 20 - "Burner 1" command and control board
- 21 - Bottom front casing
- 24 - Pressure switch against outlet blockage
- 25 - Electrical connections board
- 26 - Water outlet manifold temperature sensor
- 35 - Air vent valve
- 36 - Water outlet
- 37 - Water inlet
- 38 - Drain valve

Figure 3-3 - Internal components of models 70T

3 - MAIN COMPONENTS

**BURNER 1
(Master)**

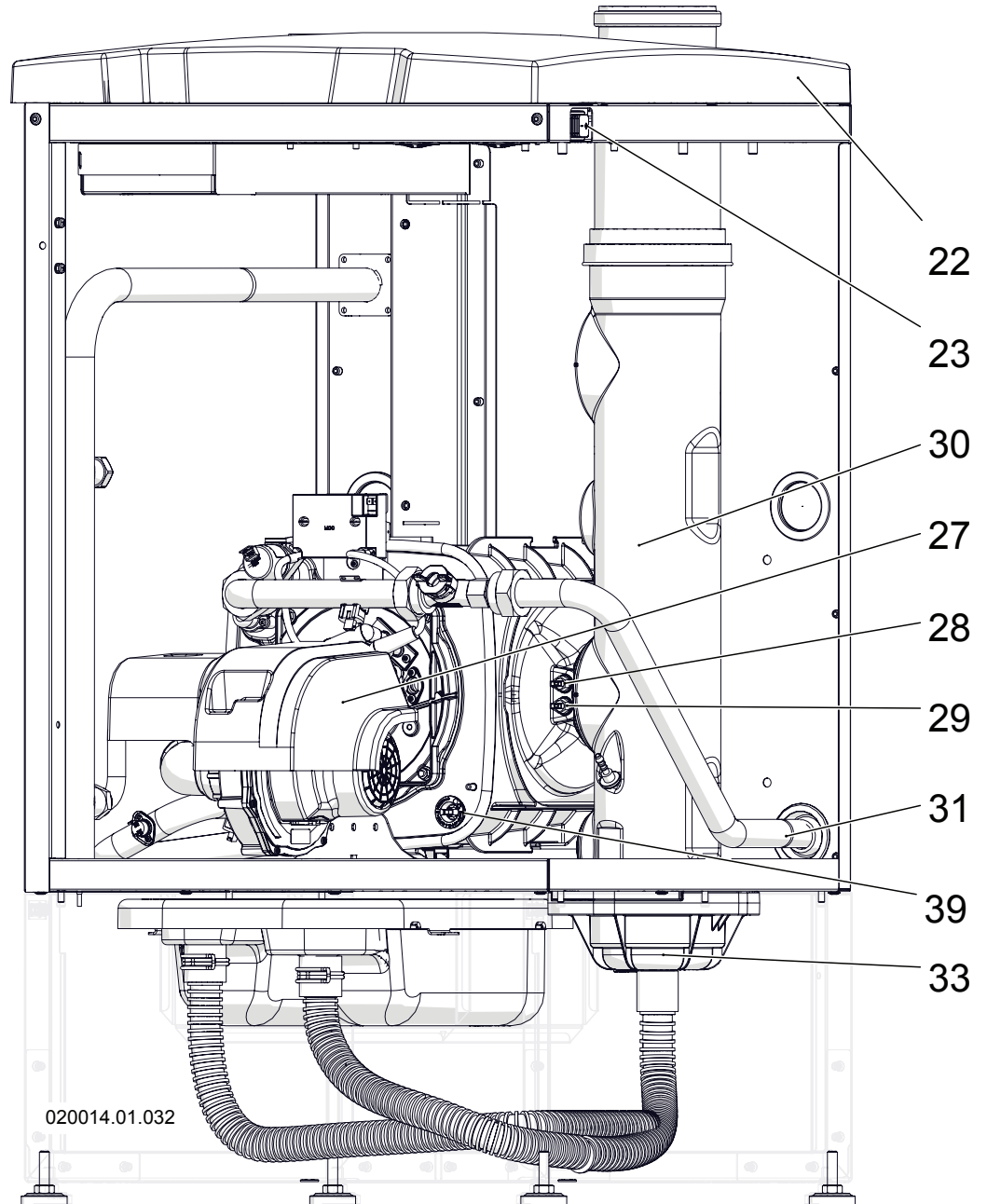

- | | |
|--|--|
| 22 - Top cover | 30 - Exhaust gases outlet manifold |
| 23 - General ON/OFF switch | 31 - Water inlet pipe |
| 27 - Fan cover | 32 - ----- |
| 28 - Exhaust gases temperature safety fuse (red connector) | 33 - Condensate level sensor |
| 29 - Exhaust gases temperature sensor (blue connector)
(1006) | 34 - ----- |
| | 39 - Primary heat exchanger temperature fuse |

Figure 3-4 - Internal components of models 70T

3 - MAIN COMPONENTS

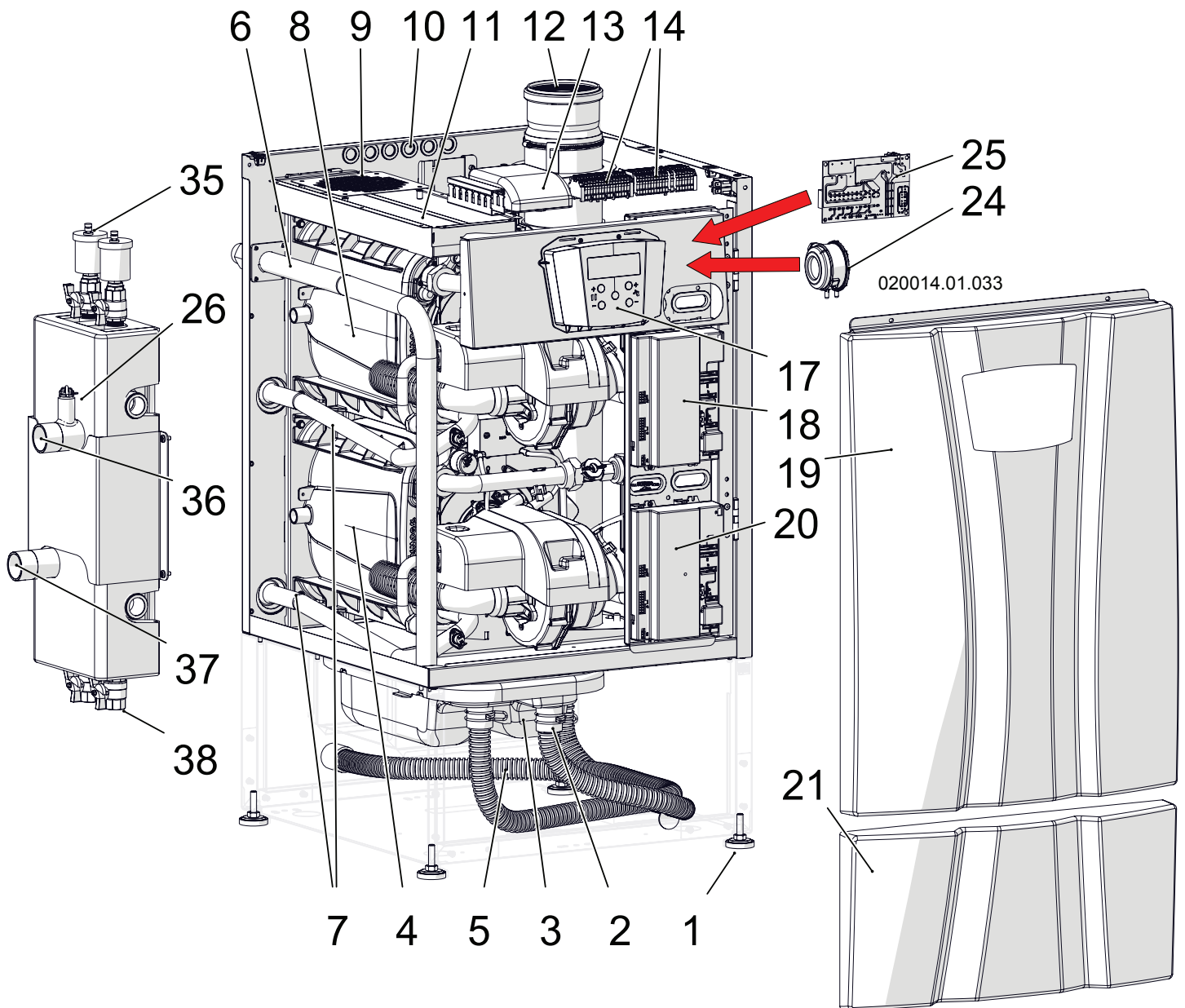

- 1 - Adjustable feet
- 2 - Exhaust gases condensate outlet pipe
- 3 - Condensate neutraliser
- 4 - Burner "1" (MASTER)
- 5 - Condensate outlet pipe
- 6 - Gas inlet pipe
- 7 - Hot water outlet pipe
- 8 - Burner "2" (SLAVE)
- 9 - Air intake
- 10 - Passage of electrical wires
- 11 - Air intake filter
- 12 - Exhaust gases outlet
- 13 - Board 885 IF (on request)
- 14 - Electrical connections

- 15 - -----
- 16 - -----
- 17 - Control panel
- 18 - "Burner 2" command and control board
- 19 - Top front casing
- 20 - "Burner 1" command and control board
- 21 - Bottom front casing
- 24 - Pressure switch against outlet blockage
- 25 - Electrical connections board
- 26 - Water outlet manifold temperature sensor
- 35 - Air vent valve
- 36 - Water outlet
- 37 - Water inlet
- 38 - Drain valve

Figure 3-5 - Internal components of models 140T

3 - MAIN COMPONENTS

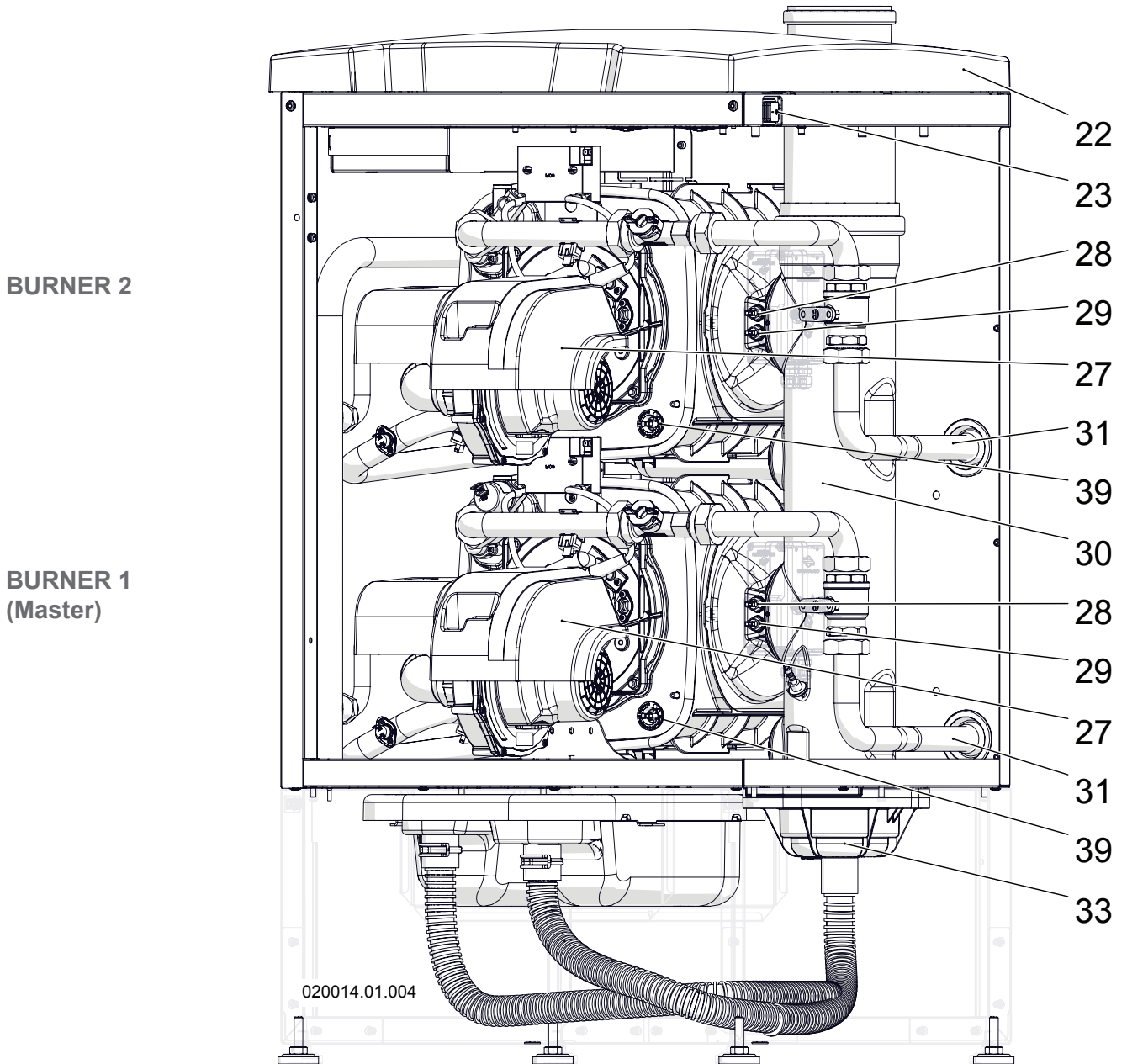

- | | |
|--|--|
| 22 - Top cover | 30 - Exhaust gases outlet manifold |
| 23 - General ON/OFF switch | 31 - Water inlet pipe |
| 27 - Fan cover | 32 - ----- |
| 28 - Exhaust gases temperature safety fuse (red connector) | 33 - Condensate level sensor |
| 29 - Exhaust gases temperature sensor (blue connector)
(1006) | 34 - ----- |
| | 39 - Primary heat exchanger temperature fuse |

Figure 3-6 - Internal components of models 140T

3 - MAIN COMPONENTS

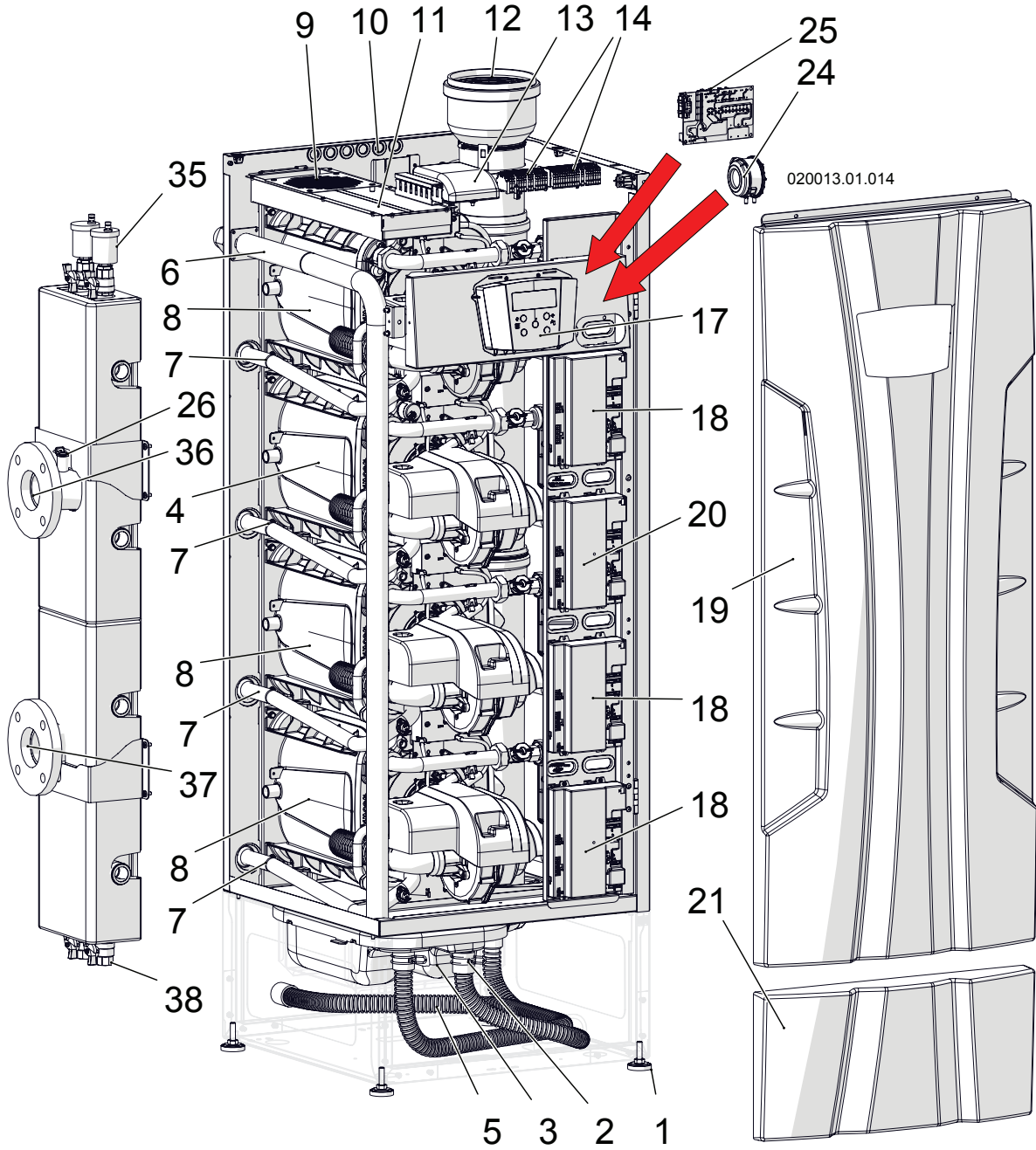

- 1 - Adjustable feet
- 2 - Exhaust gases condensate outlet pipe
- 3 - Condensate neutraliser
- 4 - Burner "1" (MASTER)
- 5 - Condensate outlet pipe
- 6 - Gas inlet pipe
- 7 - Hot water outlet pipe
- 8 - Burner "2"- "3"- "4" (SLAVE)
- 9 - Air intake
- 10 - Passage of electrical wires
- 11 - Air intake filter
- 12 - Exhaust gases outlet
- 13 - Board 885 IF (on request)
- 14 - Electrical connections

- 15 - -----
- 16 - -----
- 17 - Control panel
- 18 - Burner "2"- "3"- "4" command and control board
- 19 - Top front casing
- 20 - "Burner 1" command and control board
- 21 - Bottom front casing
- 24 - Pressure switch against outlet blockage
- 25 - Electrical connections board
- 26 - Water outlet manifold temperature sensor
- 35 - Air vent valve
- 36 - Water outlet
- 37 - Water inlet
- 38 - Drain valve

Figure 3-7 - Internal components of models 210T and 280T

3 - MAIN COMPONENTS

BURNER 2
(Not present in models 180T and 210T)

BURNER 1 (Master)

BURNER 3

BURNER 4

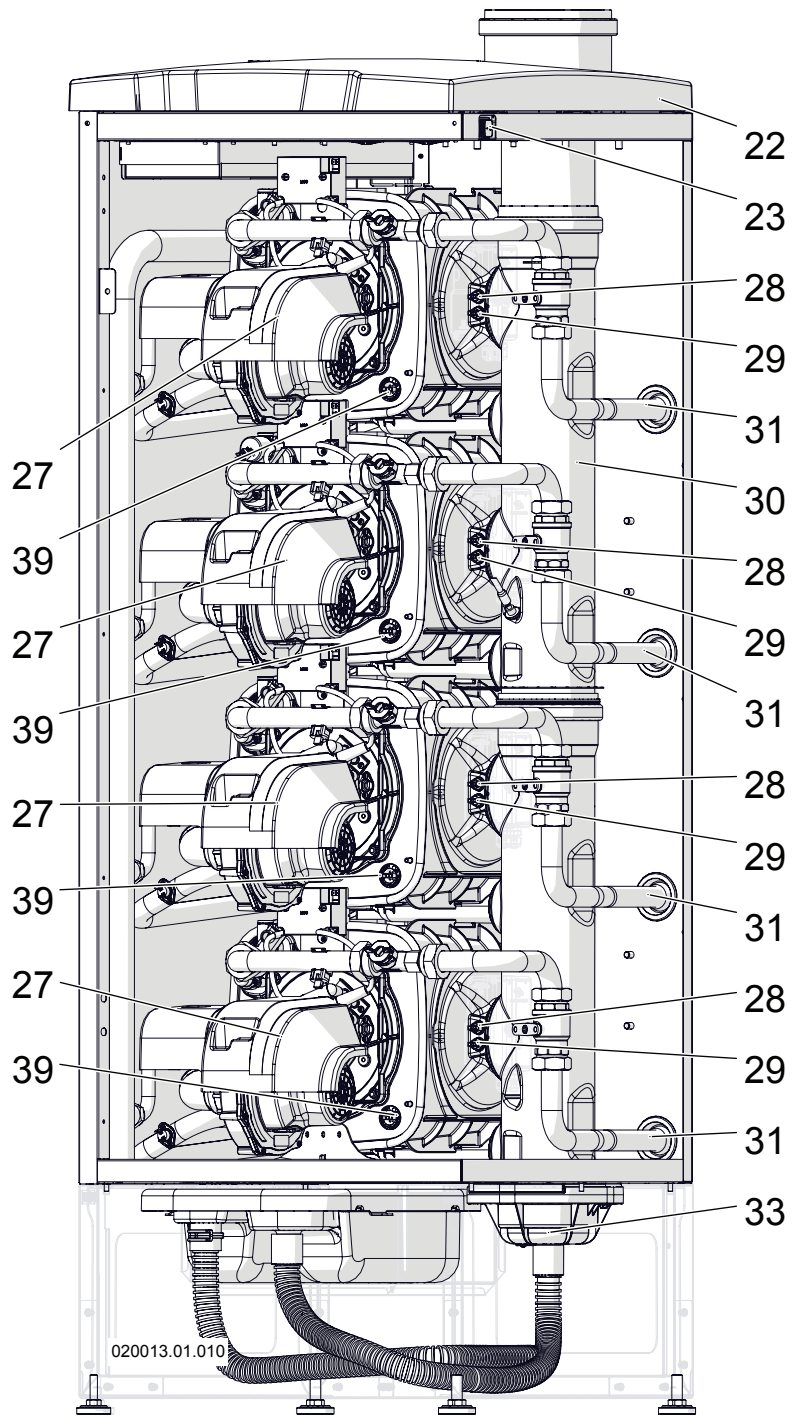

- | | |
|---|--|
| 22 - Top cover | 31 - Water inlet pipe |
| 23 - General ON/OFF switch | 32 - ----- |
| 27 - Fan cover | 33 - Condensate level sensor |
| 28 - Exhaust gases temperature safety fuse (red connector) | 34 - ----- |
| 29 - Exhaust gases temperature sensor (blue connector) (1006) | 39 - Primary heat exchanger temperature fuse |
| 30 - Exhaust gases outlet manifold | |

Figure 3-8 - Internal components of models 210T and 280T

4 - OPERATION

Figure 4-1 Key:

- 1 - Air intake
- 2 - Exhaust gases outlet
- 3 - Air vent valve
- 4 - Sealed chamber
- 6 - Water outlet temperature safety thermostat
- 7 - Water outlet temperature sensor
- 8 - Water pressure gauge
- 9 - Exhaust gases temperature sensor
- 10 - Exhaust gases temperature safety fuse
- 12 - Pre-mixed burner
- 13 - Ignition electrodes
- 14 - Sparks generator
- 15 - Water inlet temperature sensor
- 16 - Fan
- 17 - Back flue preventer valve
- 20 - Gas valve
- 22 - Detection electrode
- 24 - VRC heat exchanger
- 25 - Water outlet
- 26 - Water inlet
- 27 - Gas inlet
- 28 - Pressure switch against outlet blockage
- 29 - Condensate level sensor
- 30 - Condensate outlet
- 31 - Condensate outlet siphon
- 36 - Condensate neutraliser
- 47 - Water flow rate gauge
- 51 - Primary heat exchanger temperature fuse

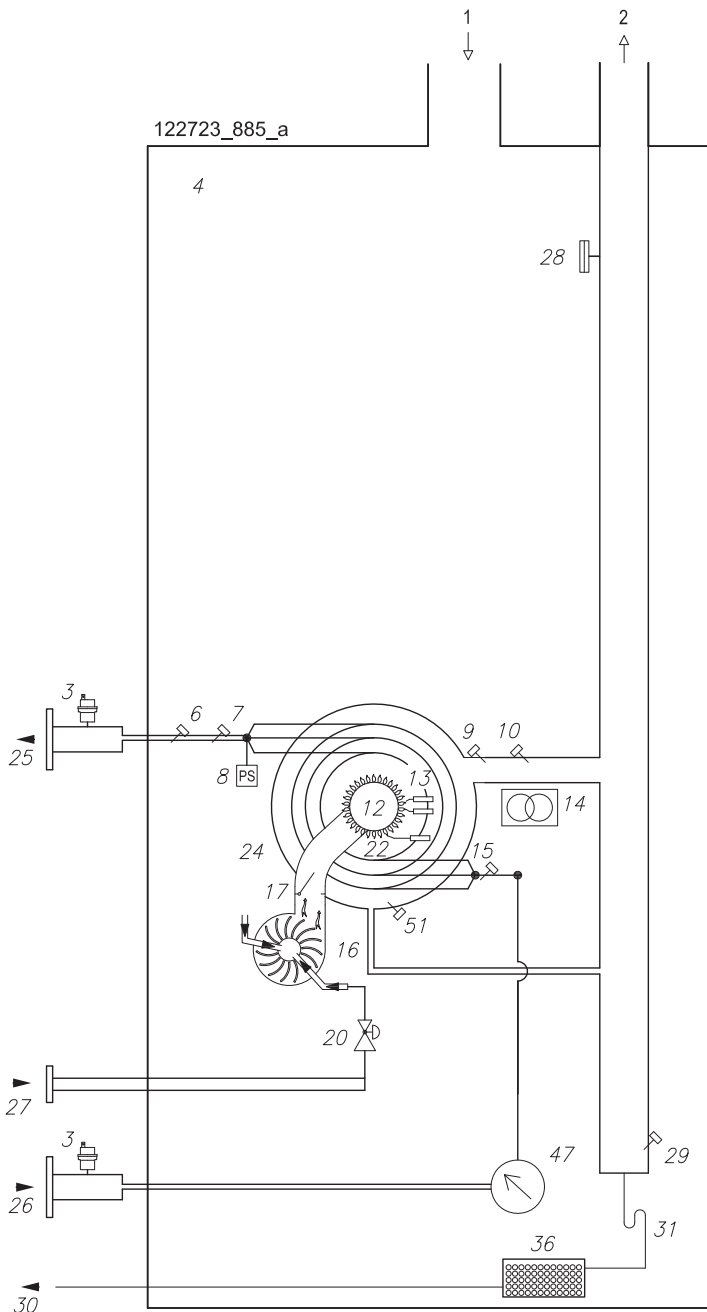

Figure 4-1 - Plumbing operating diagram for models 70T

4 - OPERATION

Figure 4-2 Key:

- 1 - Air intake
- 2 - Exhaust gases outlet
- 3 - Air vent valve
- 4 - Sealed chamber
- 6 - Water outlet temperature safety thermostat
- 7 - Water outlet temperature sensor
- 8 - Water pressure gauge
- 9 - Exhaust gases temperature sensor
- 10 - Exhaust gases temperature safety fuse
- 12 - Pre-mixed burner
- 13 - Ignition electrodes
- 14 - Sparks generator
- 15 - Water inlet temperature sensor
- 16 - Fan
- 17 - Back flue preventer valve
- 20 - Gas valve
- 22 - Detection electrode
- 24 - VRC heat exchanger
- 25 - Water outlet
- 26 - Water inlet
- 27 - Gas inlet
- 28 - Pressure switch against outlet blockage
- 29 - Condensate level sensor
- 30 - Condensate outlet
- 31 - Condensate outlet siphon
- 33 - Manifold outlet temperature sensor
- 36 - Condensate neutraliser
- 47 - Water flow rate gauge
- 48 - 2-way motorised valve (on request)
- 51 - Primary heat exchanger temperature fuse

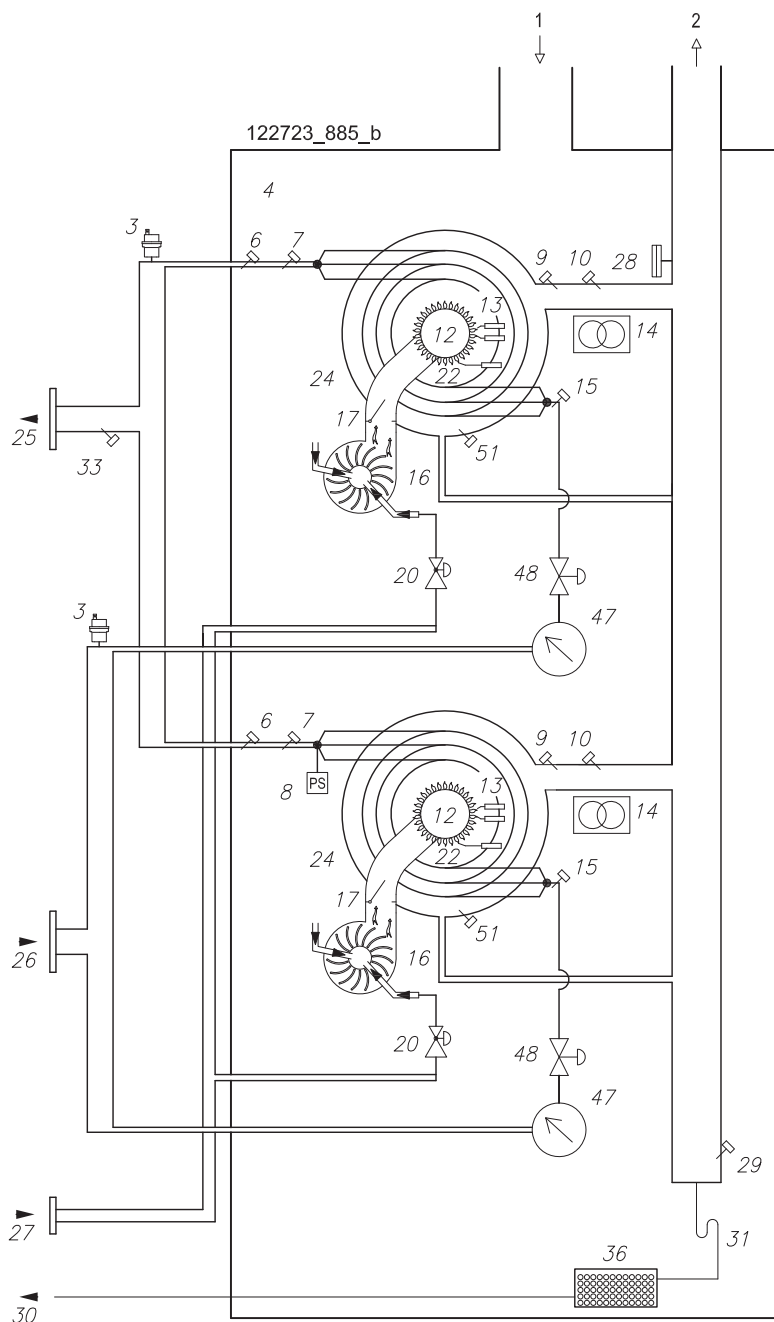

Figure 4-2 - Hydraulic operating diagram for models 140T

4 - OPERATION

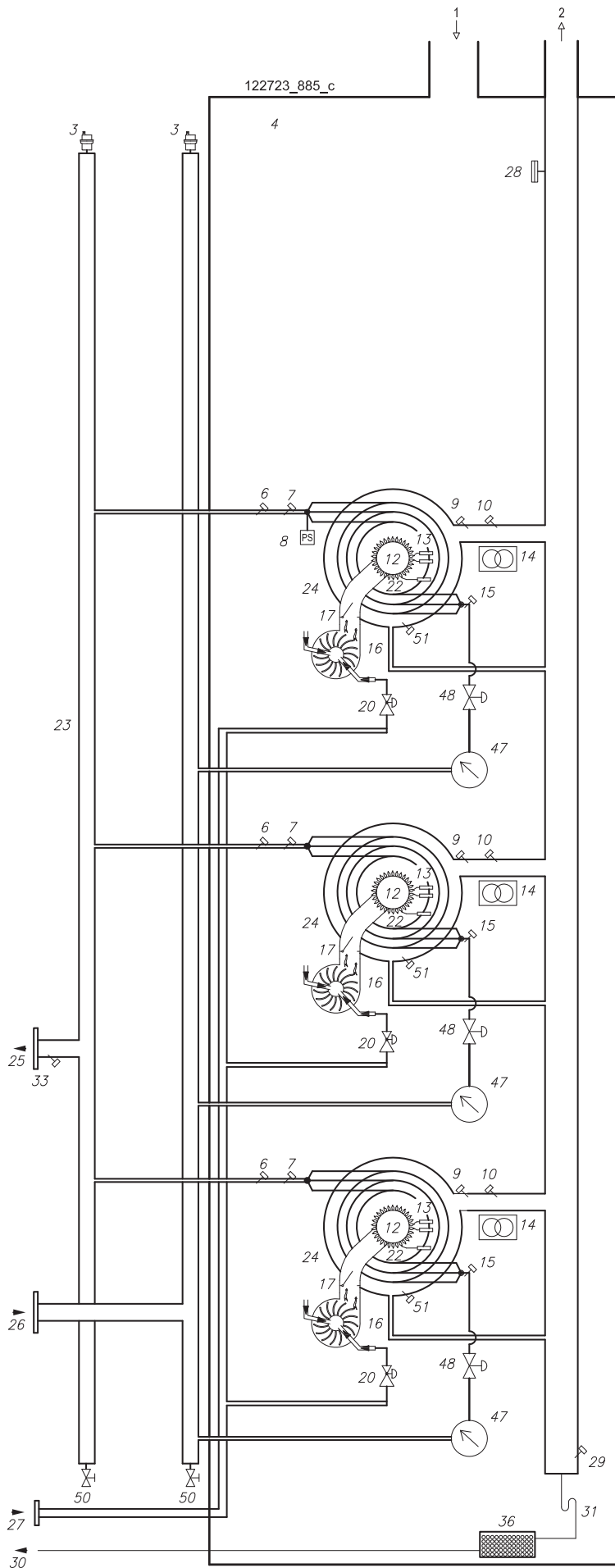

Figure 4-3 Key:

- 1 - Air intake
- 2 - Exhaust gases outlet
- 3 - Air vent valve
- 4 - Sealed chamber
- 6 - Water outlet temperature safety thermostat
- 7 - Water outlet temperature sensor
- 8 - Water pressure gauge
- 9 - Exhaust gases temperature sensor
- 10 - Exhaust gases temperature safety fuse
- 12 - Pre-mixed burner
- 13 - Ignition electrodes
- 14 - Sparks generator
- 15 - Water inlet temperature sensor
- 16 - Fan
- 17 - Back flue preventer valve
- 20 - Gas valve
- 22 - Detection electrode
- 23 - Inlet and outlet manifold
- 24 - VRC heat exchanger
- 25 - Water outlet
- 26 - Water inlet
- 27 - Gas inlet
- 28 - Pressure switch against outlet blockage
- 29 - Condensate level sensor
- 30 - Condensate outlet
- 31 - Condensate outlet siphon
- 33 - Manifold outlet temperature sensor
- 36 - Condensate neutraliser
- 47 - Water flow rate gauge
- 48 - 2-way motorised valve (on request)
- 50 - Drain valves
- 51 - Primary heat exchanger temperature fuse

Figure 4-3 - Hydraulic operating diagram for models 210T

4 - OPERATION

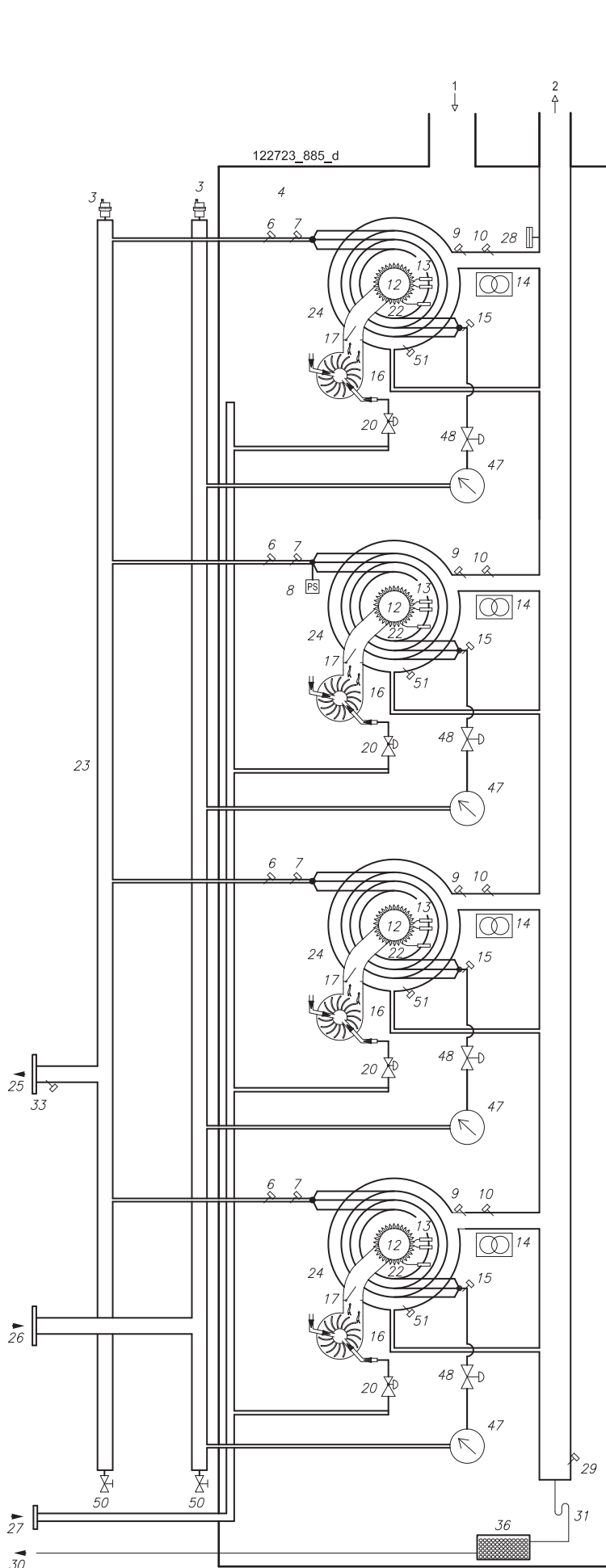

Figure 4-4 Key:

- 1 - Air intake
- 2 - Exhaust gases outlet
- 3 - Air vent valve
- 4 - Sealed chamber
- 6 - Water outlet temperature safety thermostat
- 7 - Water outlet temperature sensor
- 8 - Water pressure gauge
- 9 - Exhaust gases temperature sensor
- 10 - Exhaust gases temperature safety fuse
- 12 - Pre-mixed burner
- 13 - Ignition electrodes
- 14 - Sparks generator
- 15 - Water inlet temperature sensor
- 16 - Fan
- 17 - Back flue preventer valve
- 20 - Gas valve
- 22 - Detection electrode
- 23 - Inlet and outlet manifold
- 24 - VRC heat exchanger
- 25 - Water outlet
- 26 - Water inlet
- 27 - Gas inlet
- 28 - Pressure switch against outlet blockage
- 29 - Condensate level sensor
- 30 - Condensate outlet
- 31 - Condensate outlet siphon
- 33 - Manifold outlet temperature sensor
- 36 - Condensate neutraliser
- 47 - Water flow rate gauge
- 48 - 2-way motorised valve (on request)
- 50 - Drain valves
- 51 - Primary heat exchanger temperature fuse

Figure 4-4 - Hydraulic operating diagram for model 280T

4 - OPERATION

4.1 - Operation and intended use

4.1.1 - MYDENS boiler operation and intended use

The MYDENS product is a gas condensing boiler, designed for the production of central heating. It can also be used for the production of domestic hot water but must be connected to an appropriate storage tank (see figure 10-2). Any other use is forbidden.

The maximum power for domestic hot water service is always guaranteed in that the boiler gives priority to that service. Follow the procedure given in section 17.6 to adjust the domestic hot water temperature

The central heating system can be made with heating elements operating in a temperature range of 30°C to 80°C. The boiler can be connected to a room thermostat, an external sensor or a 0-10 VDC analogue input.

This boiler must be connected to a central heating and domestic hot water production system with power demanded that is compatible with the characteristics of the boiler itself.

4.1.2 - AGUADENS hot water heater operation and intended use

The AGUADENS product is a condensing gas boiler which must be connected to a storage tank for the production of domestic hot water (see figure 11-1).

Any other use is forbidden.

4.1.3 - Wide modulation range and maximum efficiency

Depending on the load demanded by the system, the boiler's management program can gradually switch on each individual heating element at minimum power (see figure 4-5). After which, if the load demanded by the system increases, all the heating elements gradually increase the power delivered. In this way modulated power from a minimum of 14 kW to a maximum that corresponds to the architecture of the boiler can be obtained (figure 4-5 shows a 280T module with 4 heating elements), with consequent maintaining of maximum efficiency throughout the whole range of modulation.

When the boiler is connected to an external sensor, it always works at maximum efficiency (see section 17.9).

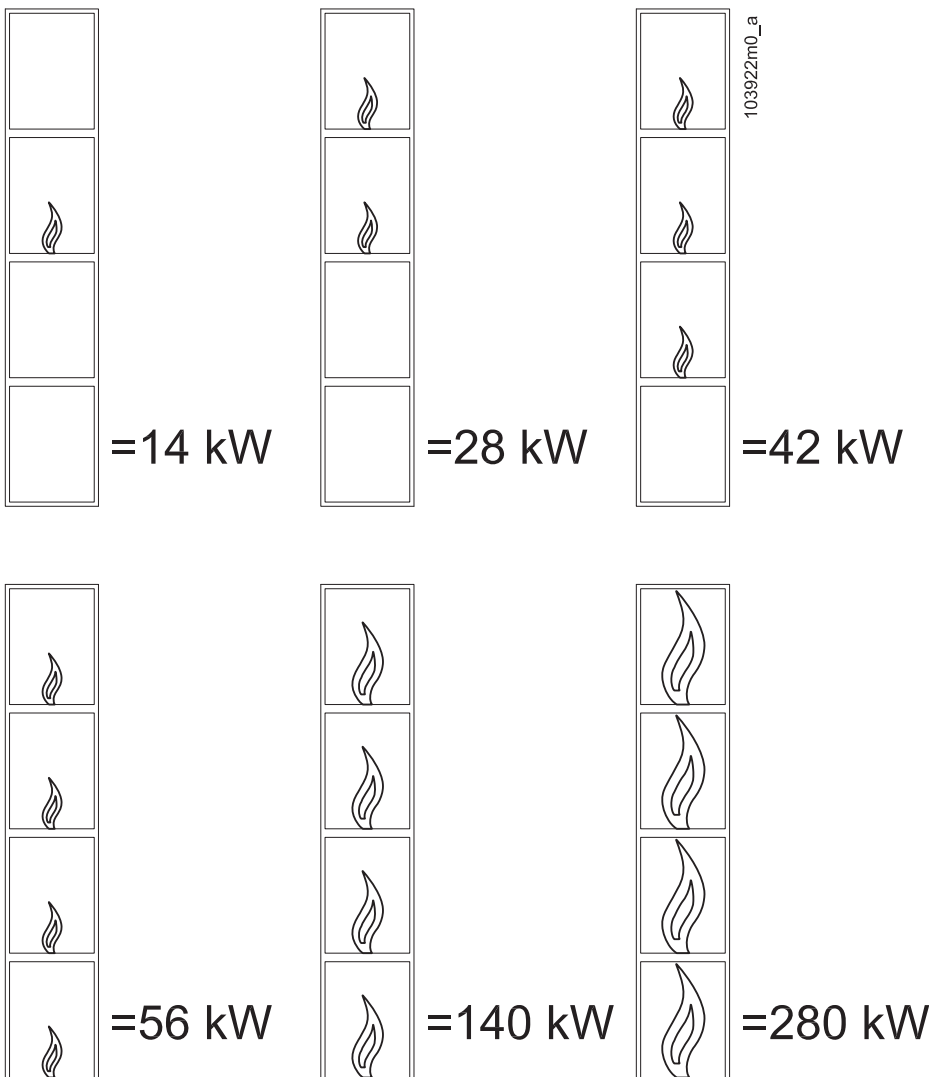

Figure 4-5 - Modulation of model 280T boiler

4 - OPERATION

This system allows the delivery temperature to be managed automatically depending on the outdoor temperature. An example of this in operation is shown in the form of a graph in figure 4-6. The graph shows an example in which the delivery and return temperatures are 55°C and 43°C respectively, and the outdoor temperature is 0°C. The external sensor commands modulation of the boiler, gradually reducing the delivery temperature and optimising efficiency. Efficiency changes from 97% when the outdoor temperature is -15°C to 105.8% with outdoor temperature of 0°C and up to 109% with outdoor temperature of 20°C.

4.1.4 - Primary circuit pump

The boiler is expressly manufactured without an internal pump in order to give the installer the option of being able to connect any pump, even a modulating one. In figures 10-1 and 10-2 the primary circuit pump is detail "36". When choosing this pump the designer must check the system features as well as the details in section 10.11.

4.1.5 - Central heating circuit pump

The central heating circuit pump, detail "19" in figures 10-1 and 10-2, is not supplied to give the installer the option of being able to connect any pump, even a modulating one. When choosing this pump the designer must check the features of the system.

4.1.6 - Domestic hot water circuit pump

The domestic hot water circuit pump, detail "28" in figure 10-2 and detail "36" in figure 11-1, is not supplied to give the installer the option of being able to connect any pump, even a modulating one. When choosing this pump the designer must check the features of the system.

4.1.7 - Hydraulic separator

If the system must be served by a water flow rate that is higher than the pump can deliver, a hydraulic separator must be inserted between the boiler and the system (see figures 10-1 and 10-2, detail "20").

4.1.8 - MYDENS boiler production of domestic hot water

For the production of domestic hot water a storage tank must be connected following the diagram in figure 10-2. The temperature of the domestic hot water is adjusted following the procedure in section 17.6.

4.1.9 - Types of system

The following types of system can be set up with this appliance:

- System solely for central heating (see figure 10-1)
- System solely for the production of domestic hot water (see figure 11-1)
- System for central heating and the production of domestic hot water (see figure 10-2)

4.2 - Precautions for installation

For the boiler to work well, respect the following directions:

- ☞ This appliance must be connected to a central heating system and if need be to a domestic hot water distribution network, compatible with the features, performance and power of the appliance itself.
- ☞ Check figures 7-1 and 7-2 regarding minimum distances to be observed for installation and future maintenance.

4.3 - Anti-Legionella

MYDENS (when connected to a storage tank) and AGUADENS appliances do not have anti-legionella protection:

It will be the responsibility of the installer to keep the temperature of the storage tank at not less than 60°C to ensure disinfection or else to use equivalent systems.

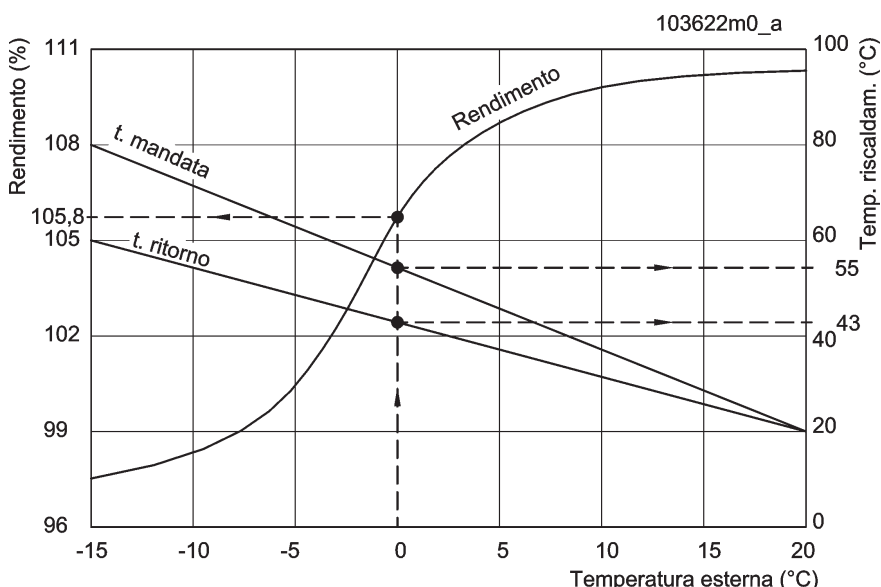

Figure 4-6 - Example of diagram of efficiency / delivery and return temperature / outdoor temperature, for a home, in a very cold area and a system with radiators.

5 - INSTALLATION - Place of installation

5.1 - Selection of place of installation



WARNING! Do not store any inflammable material in the boiler's immediate vicinity.



WARNING! Do not install the boiler on carpet.



WARNING! The boiler must be installed in a room in which there is a supply of air for ventilation and combustion, regardless of whether it is taken from outside (sealed combustion) or from inside (combustion in ventilated room).



WARNING! Inadequate ventilation of the boiler can cause elevated air temperatures.



WARNING! Make sure that the intake and outlet openings are the right size and that there are no obstructions and blockages. If the problem cannot be resolved, do not start up the boiler. Please keep in mind these restrictions and the risks they may cause to the operator.



WARNING! Liquified Petroleum Gas (LPG) - The installation needs particular attention: LPG boilers must not be installed in trenches, cellars or similar rooms in which the gas, which is heavier than air, could hang. LPG powered boilers must not be installed in places below floor level or basements. If these remarks are not respected, explosions could result and cause serious injury to people, death or enormous material damage.



WARNING! If installed in rooms with a thin floor, a resonating noise could be generated. The installation of noise-reduction elements is required.



WARNING! Do not let too much dust accumulate on the boiler.



WARNING! The boiler must only be installed on a solid floor, which takes its weight and is level.

☞ Before installing the appliance, the central heating system and, if necessary, the domestic hot water system must be washed thoroughly in order to remove any residues or impurities which could compromise the working order of the boiler.

☞ This boiler is not designed to be installed in the open air, it must not be exposed to temperatures below 0.5°C or above 50°C. Choose a place inside the building or somewhere sheltered from weather such as rain, wind, sun and, above all, frost.

☞ This appliance must be installed in a place where water leakages from the appliance itself, from the joints between the pipes or from any drainage from the safety valve, cannot cause damage to materials or items below it.

Choose the room and suitable position for installation, taking into account the following factors:

- connection to smoke outlet/air intake ducts;
- connection to gas adduction duct;
- connection of the water supply;
- connection to the central heating system;
- connection to domestic hot water system (where present);
- electric connection;
- connection to outlet for condensate produced by the boiler;
- electric connection of the room thermostat;
- connection to safety valve outlet;
- connection to the outdoor temperature sensor (where applicable);
- room ventilation.

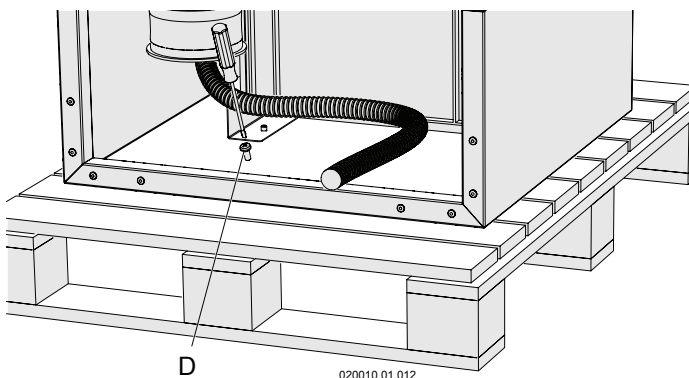
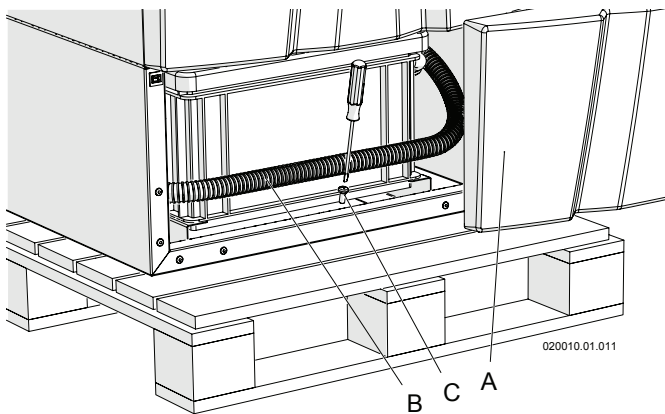

Figure 5-1 - Undoing transport pallet screws

5 - INSTALLATION - Place of installation

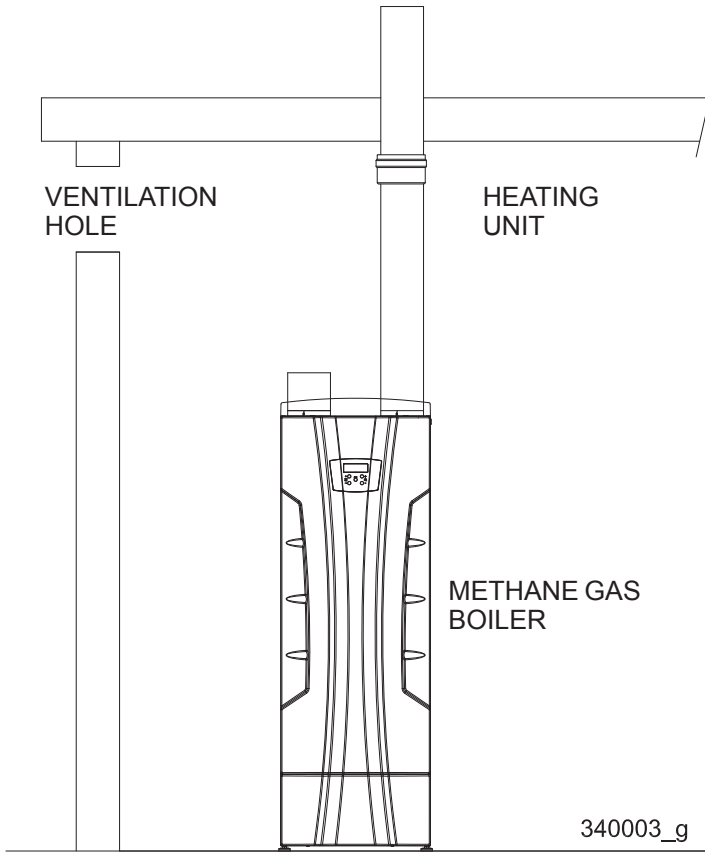

Figure 5-2 Example of ventilation with methane gas boiler

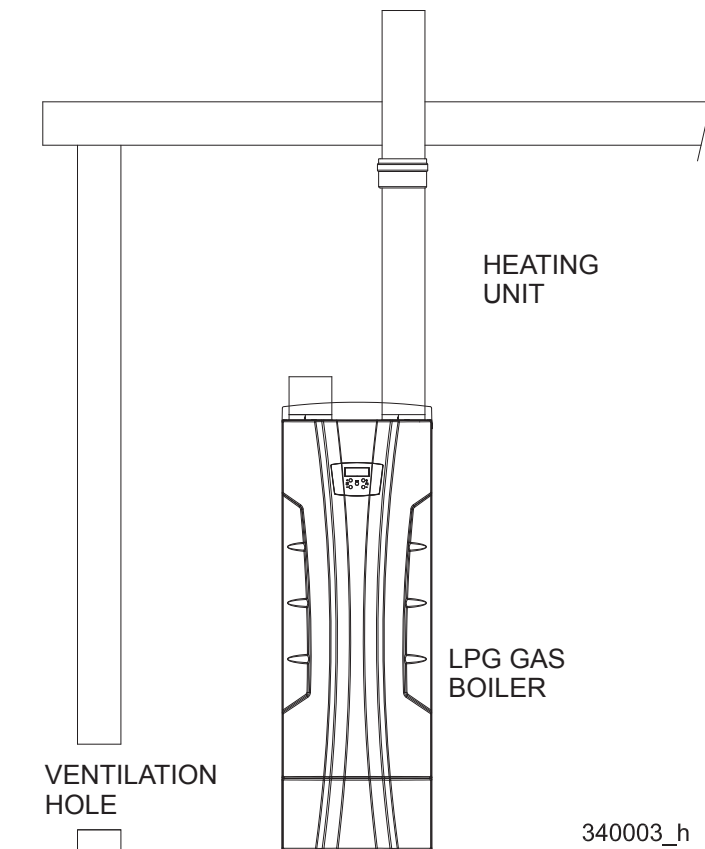

Figure 5-3 Example of ventilation with LPG gas boiler

5.1.1 - Requirements for correct ventilation

The technical room MUST be provided with an air vent of the correct size. To ensure appropriate ventilation for combustion, in line with the requirements of national and local regulations in force, pay attention to the following:

A single direct opening to the outside is required for combustion; this must have a minimum area of 3000 cm² or 5000 cm² if the boiler is fuelled by LPG. This opening must be positioned at least 30 cm from the ceiling if it is fuelled by METHANE gas (see fig. 5-2) or at floor level if it is fuelled by LPG (see fig. 5-3).

The openings must communicate directly with the outside. The requirements described above refer to a single boiler; rooms in which there are more than one boiler require an increase in free area to provide adequate ventilation for combustion in all the boilers.



WARNING! There must never be negative pressure in the heating unit. For this reason you must take into account the presence of any outlet fans, ceiling fans, dryers, compressors, air heating units, etc. that might take air away from the boiler.



WARNING! Extractors or similar devices for the removal of air from the heating unit might reduce the ventilation required for combustion and/or cause low pressure in the ventilation system. Escapes of exhaust gases from the ventilation system in an occupied habitable room can cause a very dangerous situation which must be corrected immediately.

5.1.2 - Preventing contamination of combustion air

Do not locate extractor and/or exhaust gases outlet terminals in rooms where the combustion air may be contaminated.



WARNING! Contaminated fuel air can damage the boiler.

Make sure that the combustion air does not contain any of the following contaminating agents:

Products that might contaminate the fuel air:

- Permanent wave solutions;
- Chlorinated waxes/detergents;
- Chlorine-based chemical products for swimming pools;
- Calcium chloride used for defrosting;
- Sodium chloride used to soften the water;
- Leaks of refrigerant;
- Varnish or paint removal solutions;
- Hydrochloric acid/muriatic acid;
- Cements and adhesives;
- Anti-static softeners used in tumble dryers;
- Chlorine-type bleaches, detergents and cleaning solvents found in utility rooms for domestic use;
- Adhesives used to glue construction products and other similar products;

6 - INSTALLATION - Setup

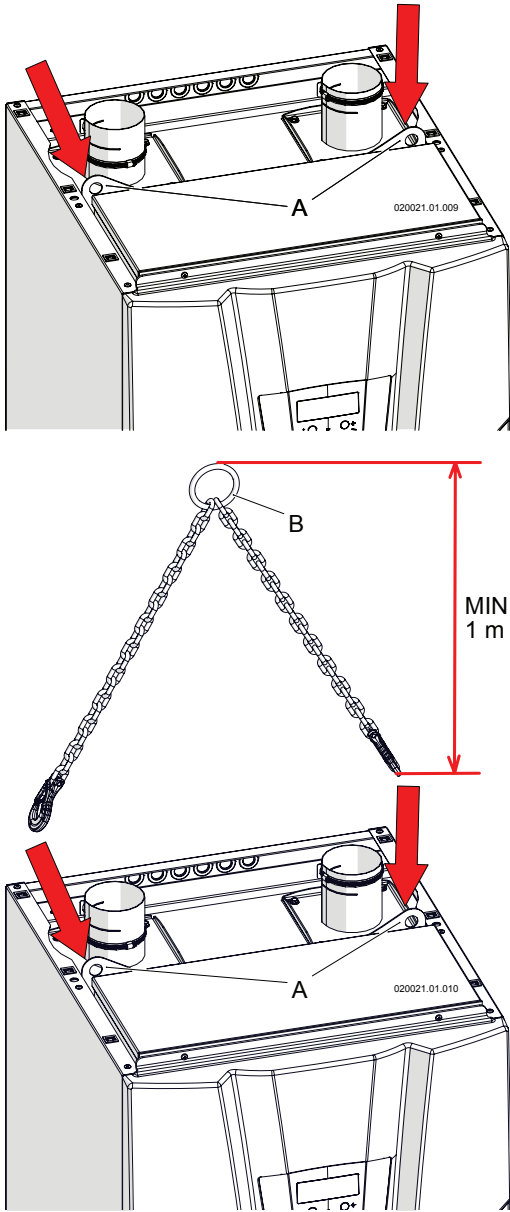

Figure 6-1 - Lifting system

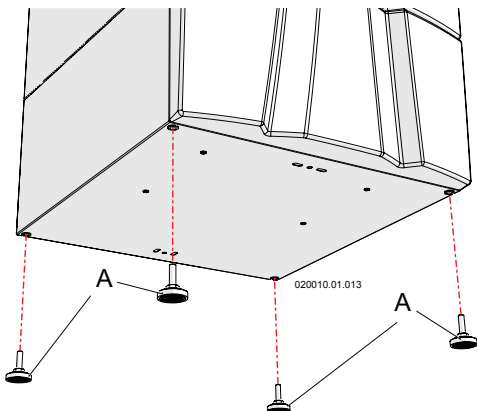

Figure 6-2 - Feet to make it level

6.1 - Setup

To install the boiler correctly and easily, the following steps must be scrupulously followed.

6.1.1 - Moving the boiler



WARNING! Use trolleys suitable for the type of boiler to move it. Not doing this could cause serious harm.

Position the boiler in the area selected for installation, moving it using the pallet it is fixed to, taking care to keep it vertical without making any sharp movements that might cause it to overturn.

To remove the boiler from the pallet, undo the front (detail "C" in figure 5-1) and rear (detail "D" in figure 5-1) fixing screws.

6.1.2 - Opening the package

The boiler is supplied in a cardboard package, fixed to the pallet for transportation. Be careful when opening it, take the cardboard box off by lifting it upwards, after detaching it from the pallet.

6.1.3 - Lifting the boiler

For convenience during installation, a rod is provided (detail "A" in figure 6-1) which enables the boiler to be lifted.

- ☞ remove the top cover as in section 18.2;
- ☞ hook lifting cables, "B" in figure 6-1, onto the rod, "A" in figure 6-1 and lift the heating unit;



WARNING! The cables and lifting system must be suitable for the purpose envisaged. In particular, they must be able to bear the weight of the boiler which you can check in section 19.

- ☞ install the adjustable feet "A" to make the boiler level as shown in figure 6-2.

Once the boiler is in the correct position the lifting cables (detail "B" in figure 6-1) must be removed before the top cover is put on.

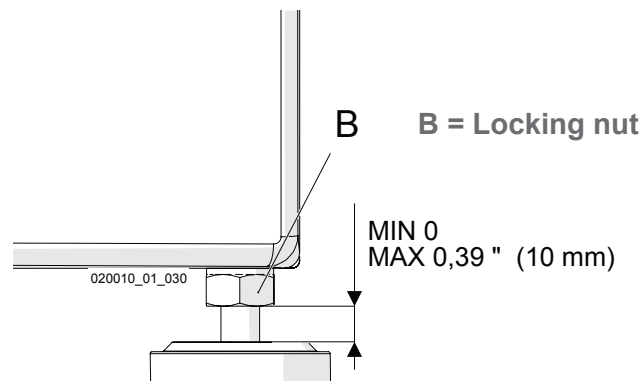

7 - INSTALLATION - Minimum distances to be observed

7.1 - Dimensions and minimum distances to be observed

For both installation and maintenance, it is necessary to leave free spaces around the boiler, as shown in figures 7-1 and 7-2. The dimensions and connection centre space distances for the boilers are shown in figures 8-1, 8-2, 9-1 and 9-2.

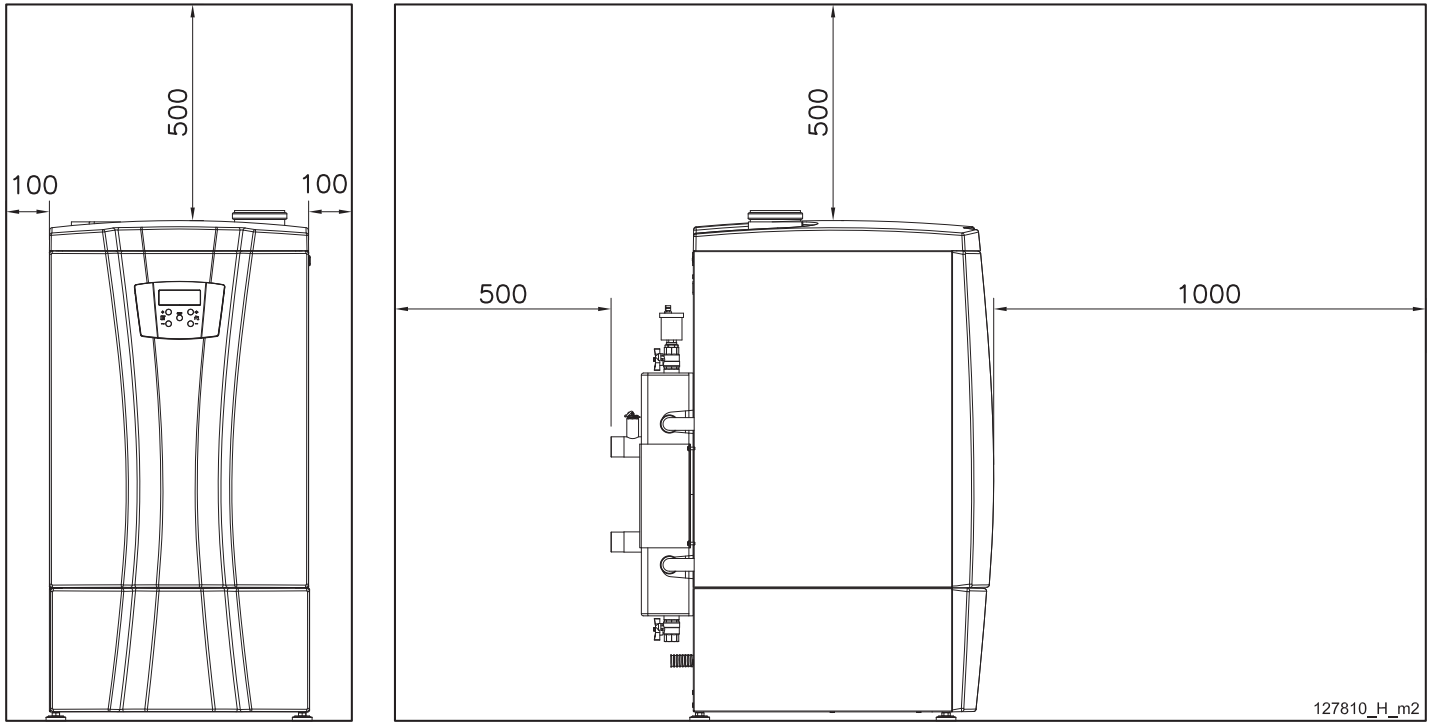

Figure 7-1 - Minimum distances to be observed for models 70T and 140T

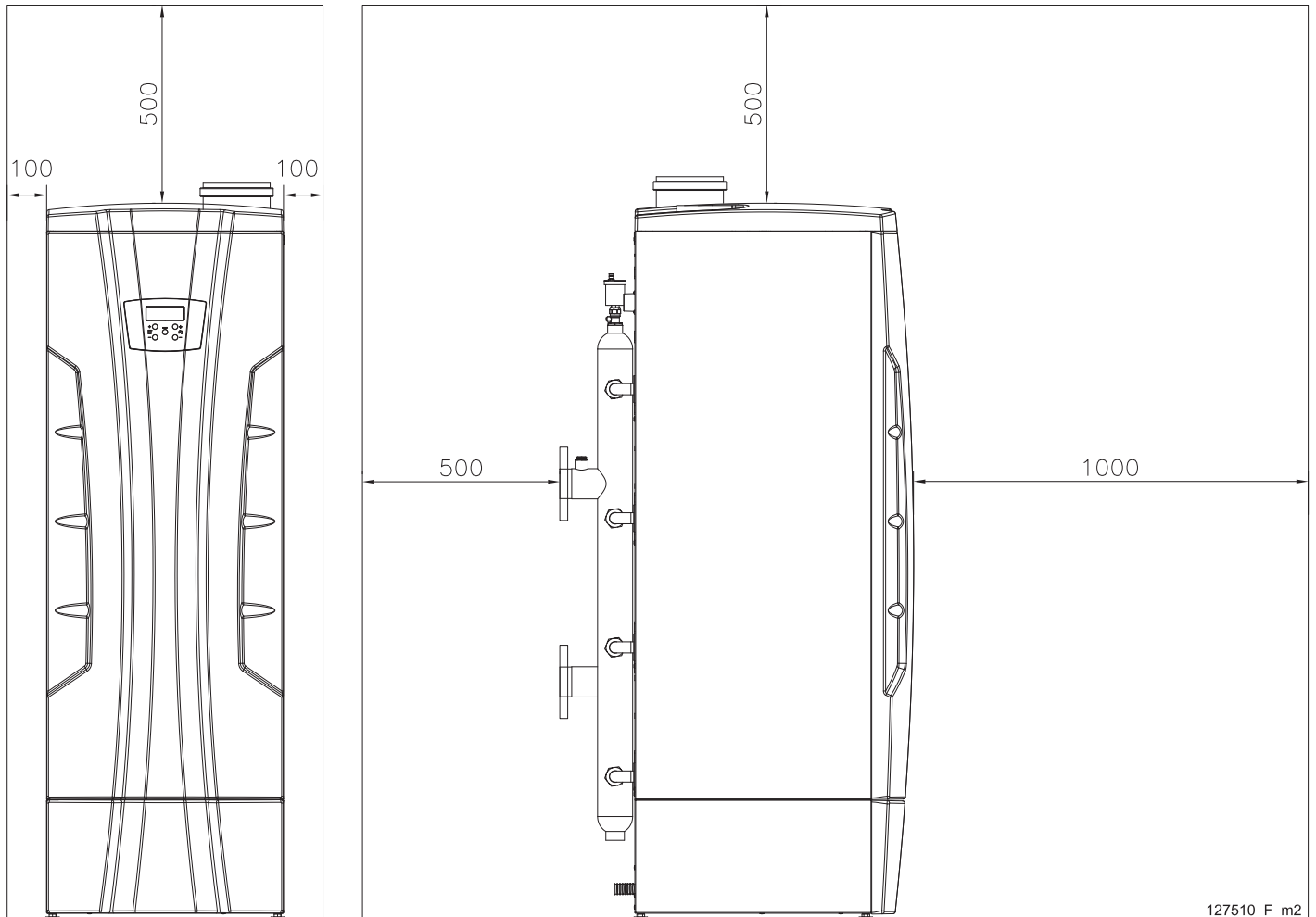

Figure 7-2 - Minimum distances to be observed for models 210T and 280T

8 - INSTALLATION - Dimensions and centre space distances - MYDENS boiler

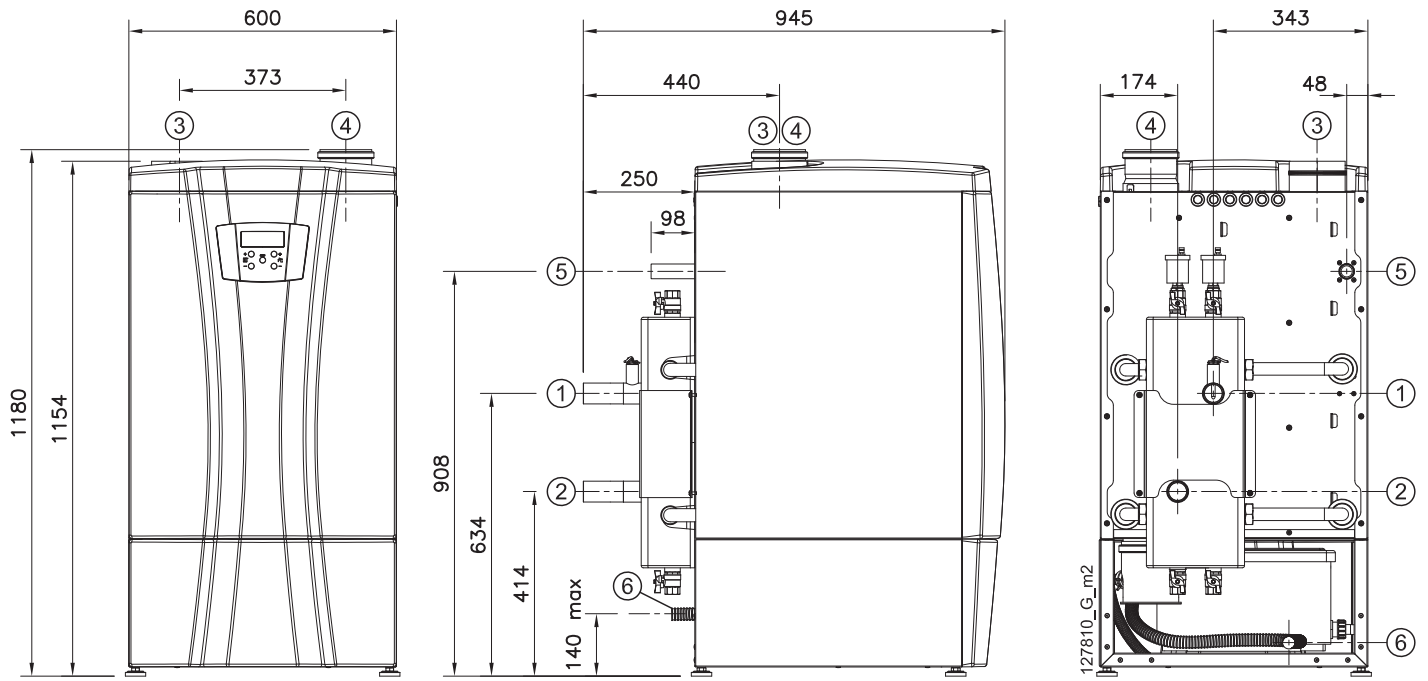

Figure 8-1 - Dimensions and centre space distances of attachments for models 70T and 140T (References in figure 8-3)

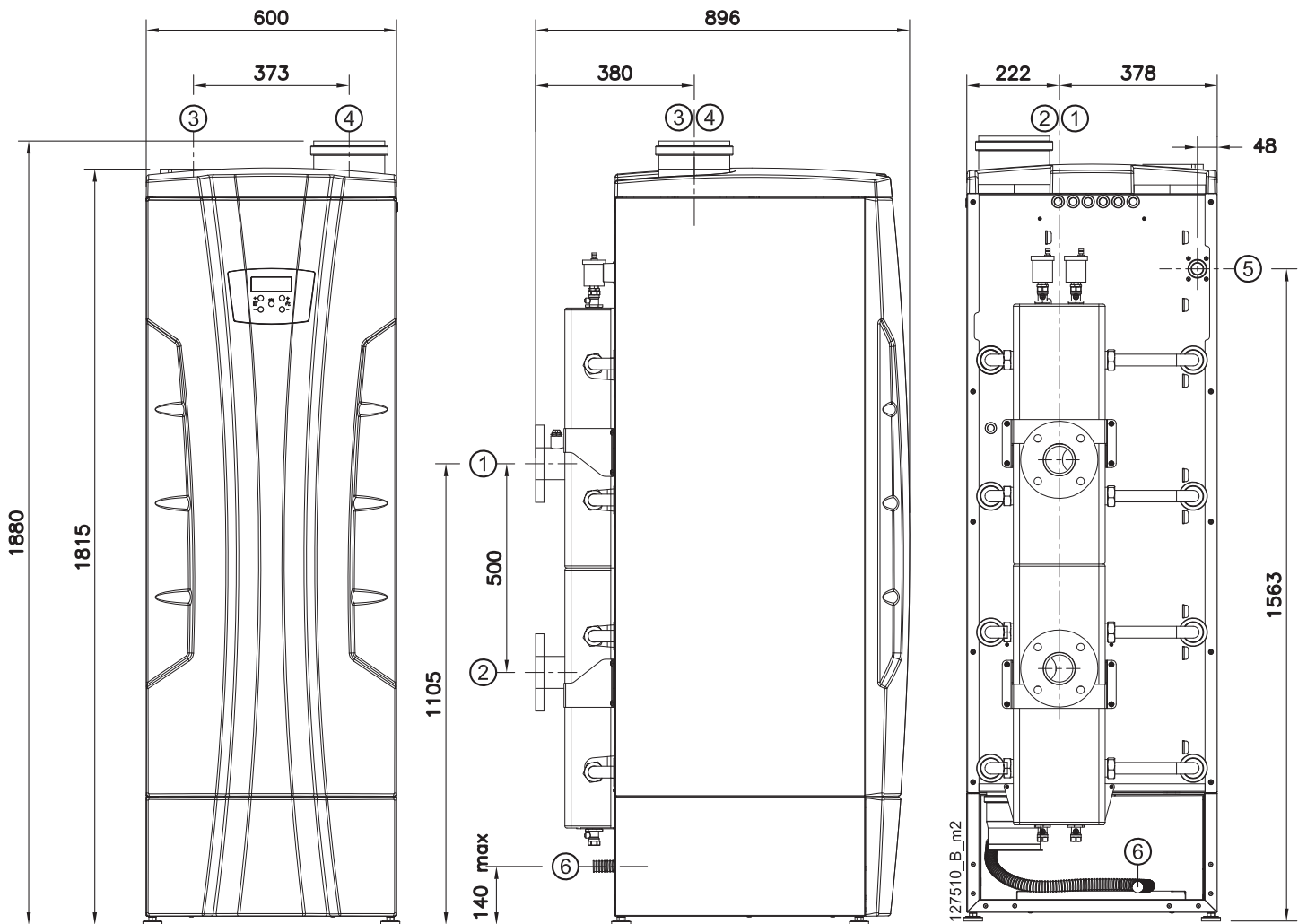

Figure 8-2 - Dimensions and centre space distances of attachments for models 210T and 280T (References in figure 8-3)

8 - INSTALLATION - Dimensions and centre space distances - MYDENS boiler

MODEL	① DELIVERY	② RETURN	③ AIR INTAKE	④ FLUE GAS OUTLET	⑤ GAS	⑥ CONDENSATE OUTLET
70T	1"1/2 *	1"1/2 *	136 mm **	110 mm	1"	28 mm
140T	1"1/2 *	1"1/2 *	136 mm **	110 mm	1"	28 mm
180T	DN65 PN16 *	DN65 PN16 *	136 mm **	160 mm	1"1/4	28 mm
280T	DN65 PN16 *	DN65 PN16 *	136 mm **	160 mm	1"1/4	28 mm

* Connections and flanges are not factory fitted;

** Air intake in room, do not obstruct and do not add any connection;

Figure 8-3 - Table of diameters of connections in figures 8-1 and 8-2

9 - INSTALLATION - Dimensions and centre space distances - AGUADENS hot water heater

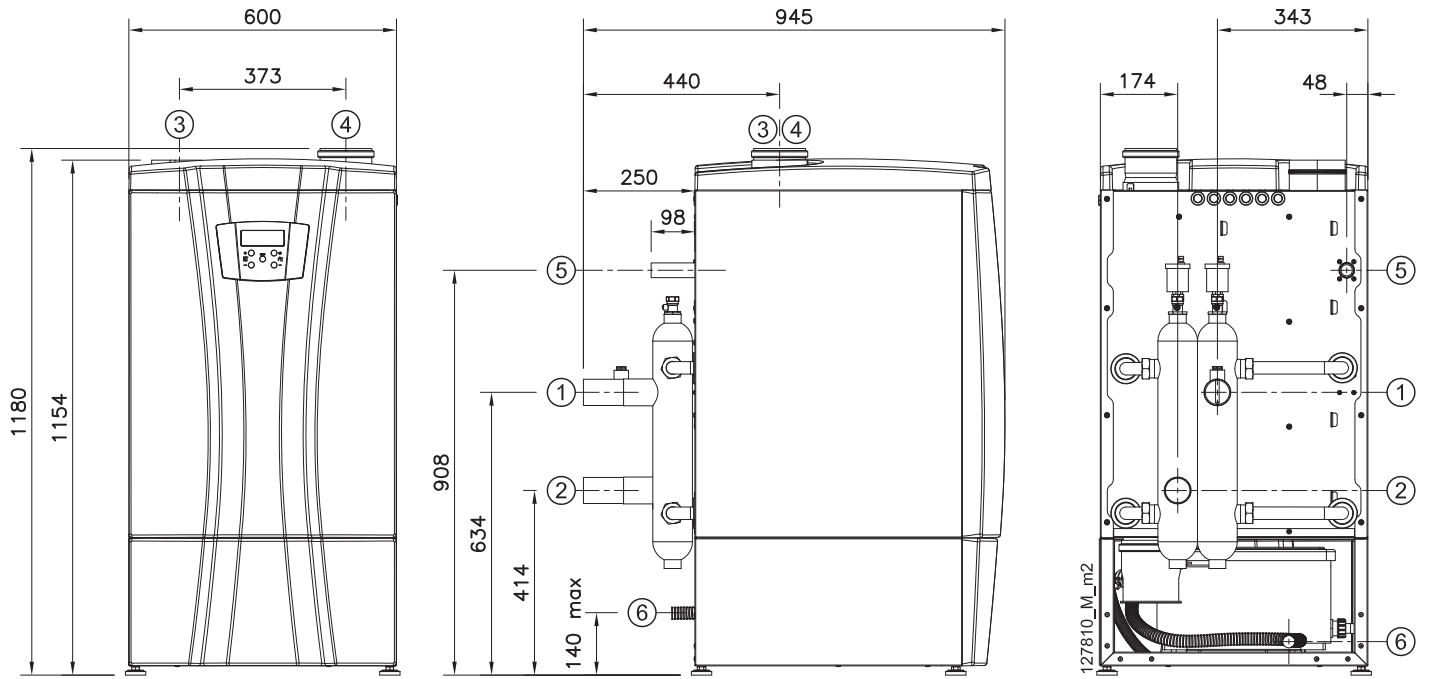

Figure 9-1 - Dimensions and centre space distances of attachments for models 70T and 140T (References in figure 9-3)

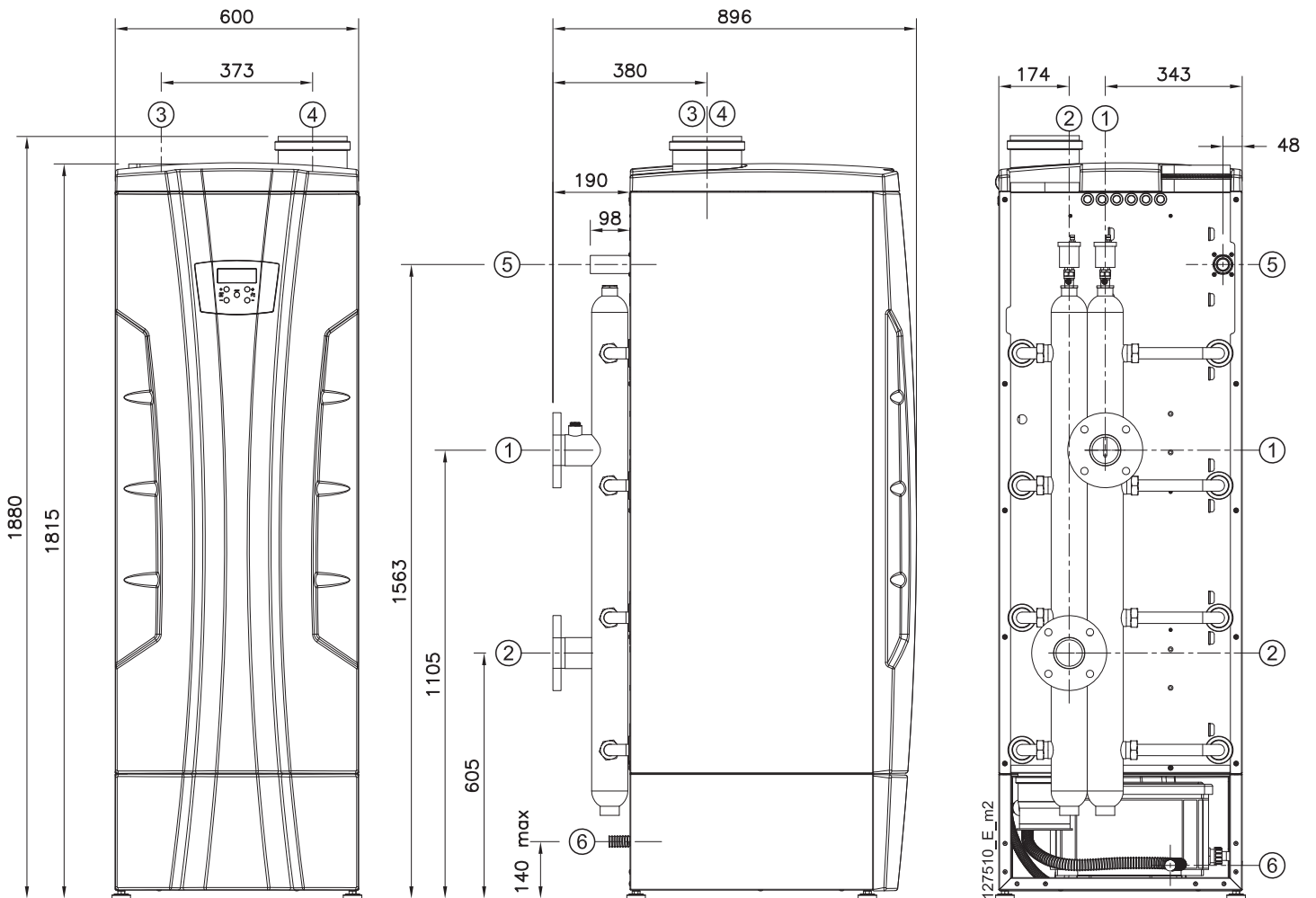

Figure 9-2 - Dimensions and centre space distances of attachments for models 210T and 280T (References in figure 9-3)

9 - INSTALLATION - Dimensions and centre space distances - AGUADENS hot water heater

MODEL	① WATER OUTLET	② WATER INLET	③ AIR INTAKE	④ FLUE GAS OUTLET	⑤ GAS	⑥ CONDENSATE OUTLET
70T	1"1/2 *	1"1/2 *	136 mm **	110 mm	1"	28 mm
140T	1"1/2 *	1"1/2 *	136 mm **	110 mm	1"	28 mm
210T	DN65 PN16 *	DN65 PN16 *	136 mm **	160 mm	1"1/4	28 mm
280T	DN65 PN16 *	DN65 PN16 *	136 mm **	160 mm	1"1/4	28 mm

* Connections and flanges are not factory fitted;

** Air intake in room, do not obstruct and do not add any connection;

Figure 9-3 - Table of diameters of connections in figures 9-1 and 9-2

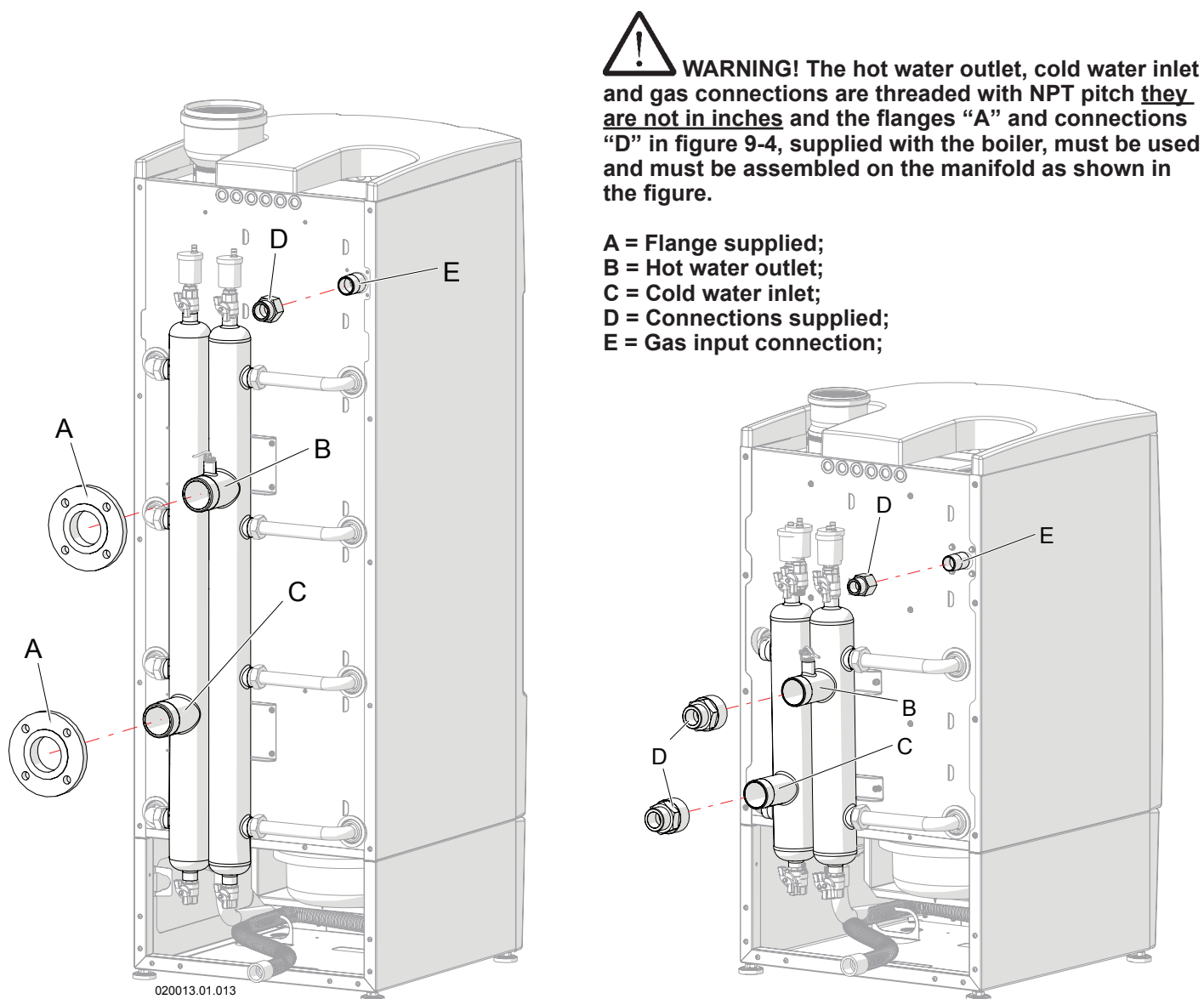

Figure 9-4 - Assembly of flanges and reductions on threaded connections for hot water outlet, cold water inlet and gas

10 - INSTALLATION - Plumbing connections - MYDENS boiler

10.1 - MYDENS boiler plumbing and gas connections

WARNING! Before installing the appliance, the central heating system and, if necessary, the domestic hot water system must be washed thoroughly in order to remove any residues or impurities which could compromise the working order of the boiler.

To identify the position of the connections, see figures 8-1 and 8-2.

Gas connection

Connecting to the gas must be made to the relative attachment with a rigid metal pipe. The capacity of the gas meter must be adequate for the simultaneous use of all the gas boilers connected to it. Connect the boiler to the gas, as required by the regulations in force. The diameter of the gas pipe that comes out of the boiler, is not a determining factor when choosing the diameter of the pipe between the boiler and the meter; it must be chosen according to its length and to head losses.

WARNING! It is recommended that a gas isolation valve should be installed immediately before the boiler, in order to allow the gas supply to be interrupted.

WARNING! Do not power the appliance with gases other than those specified.

10.2 - MYDENS boiler safety valve (responsibility of the installer)

The boiler is supplied with no safety valve against too high pressure, so that the installer is able to choose the valve that suits the system's operating pressure (check the operating pressure of the boiler in the technical data section). The installation must be carried out in such a way as to allow the user to check it has intervened when the valve is opened. The safety valve outlet (responsibility of the installer) must be orientated in such a way as to avoid danger for people if it intervenes.

WARNING! If you do not route the safety valve, it might cause harm to people, animals or things if it has to intervene.

10.3 - Examples of installation of MYDENS boiler

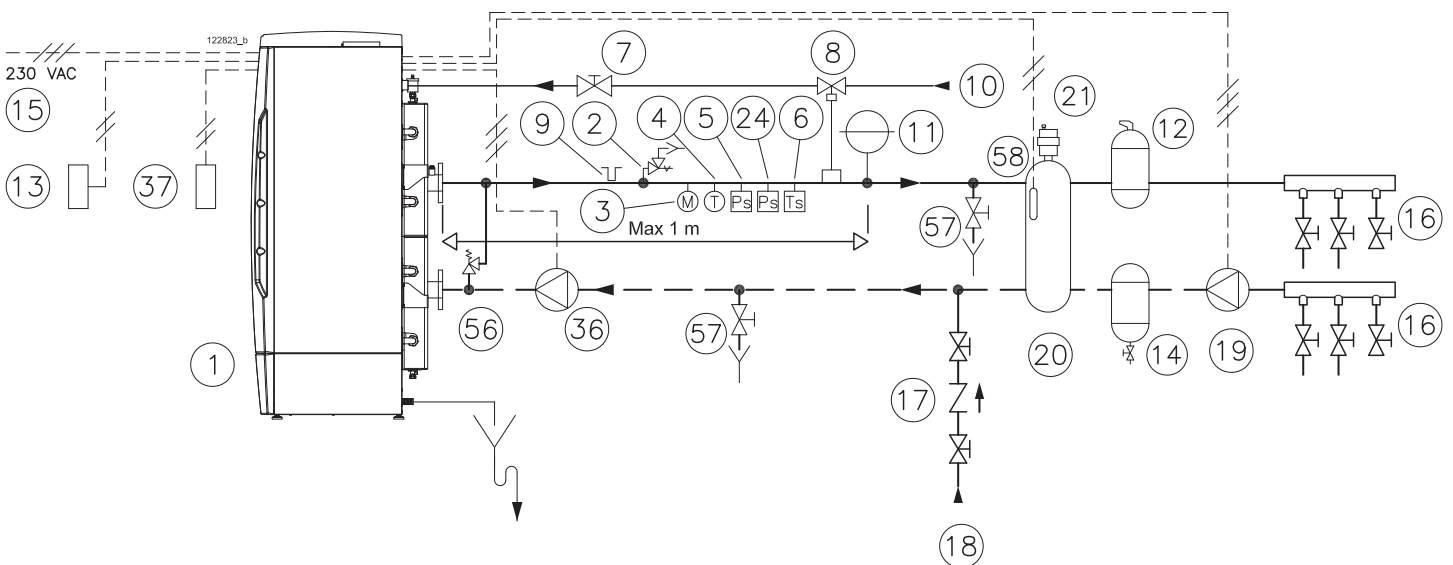

Figure 10-1 - MYDENS boiler example of connection diagram

Figure 10-1 KEY

- | | |
|--|---|
| 1 MYDENS boiler model 60T-280T | 16 Low or high temperature heating system |
| 2 INAIL safety valve | 17 System load assembly |
| 3 INAIL pressure gauge | 18 Cold DHW |
| 4 INAIL thermometer | 19 Central heating circuit pump |
| 5 INAIL maximum safety pressure switch | 20 Hydraulic separator |
| 6 INAIL safety thermostat | 21 Air vent valve |
| 7 Gas cock | 23 ----- |
| 8 INAIL Gas isolation valve | 24 INAIL minimum safety pressure switch |
| 9 INAIL basin | 36 Primary circuit pump |
| 10 Gas inlet | 37 Room thermostat or equivalent system |
| 11 Expansion tank | 56 Balancing valve (necessary if there is in the boiler the motorised valve, detail "17" in figure 3-1 and pump "36" is NOT the modulating type) |
| 12 Microbubble separator | 57 - Drain cock |
| 13 External sensor | 58 - Manifold sensor |
| 14 Filter | |
| 15 Electric power supply | |

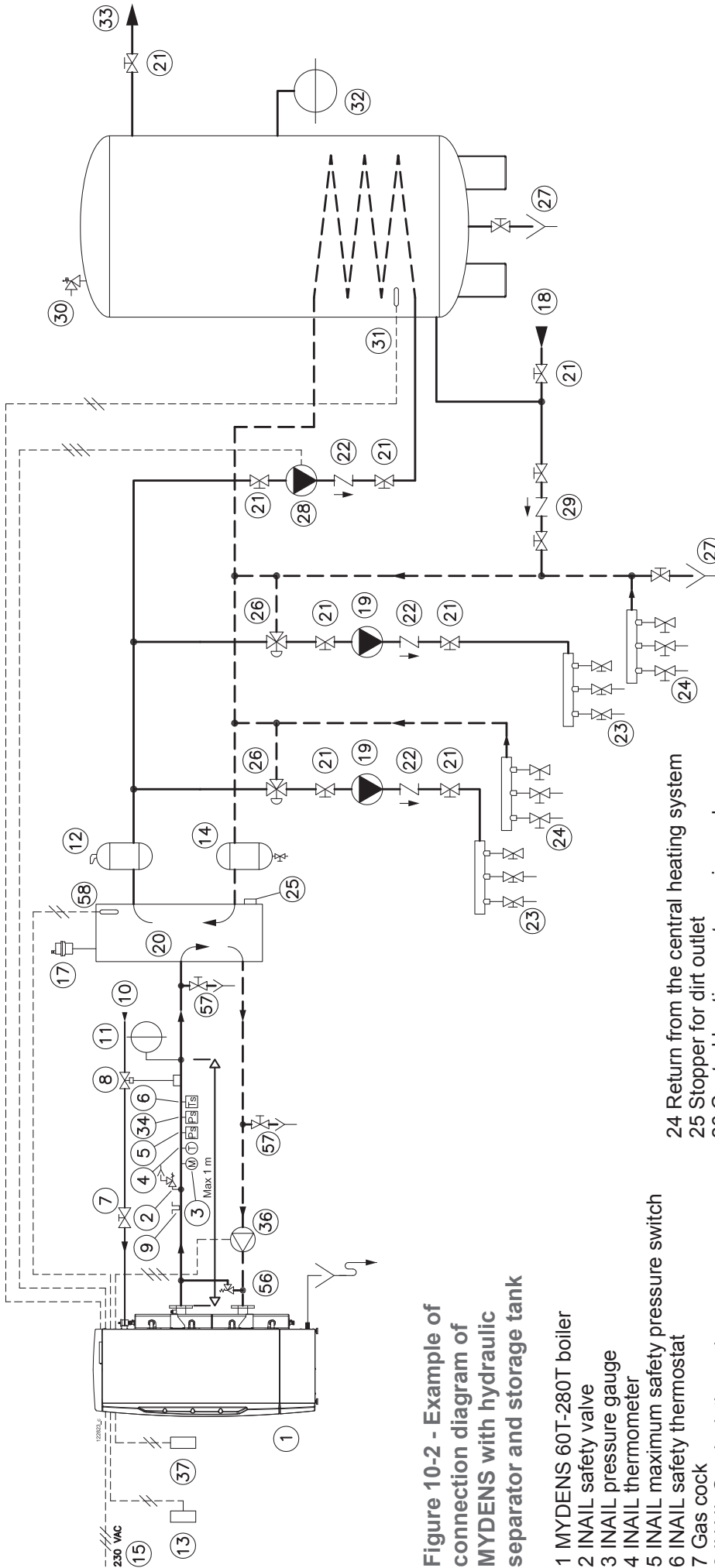

Figure 10-2 - Example of connection diagram of MYDENS with hydraulic separator and storage tank

- | | |
|---|---|
| 1 MYDENS 60T-280T boiler | 24 Return from the central heating system |
| 2 INAIL safety valve | 25 Stopper for dirt outlet |
| 3 INAIL pressure gauge | 26 Central heating system mixer valve |
| 4 INAIL thermometer | 27 System outlet |
| 5 INAIL maximum safety pressure switch | 28 Storage tank load pump |
| 6 INAIL safety thermostat | 29 System load assembly |
| 7 Gas cock | 30 Storage tank safety valve |
| 8 INAIL Gas isolation valve | 31 Storage tank temperature sensor |
| 9 INAIL basin | 32 Domestic hot water circuit expansion tank |
| 10 Gas inlet | 34 INAIL minimum safety pressure switch |
| 11 Expansion tank | 36 Primary circuit pump |
| 12 Microbubble separator | 37 Room thermostat or equivalent system |
| 13 External sensor | 56 Balancing valve (necessary if there is in the boiler the motorised valve, detail "17" in figure 3-1 and pump "36" is NOT the modulating type) |
| 14 Filter | 57 - Drain cock |
| 15 Electric power supply | 58 - Manifold sensor |
| 16 ----- | |
| 17 Air vent valve | |
| 18 Cold DHW | |
| 19 Central heating circuit pump | |
| 20 Hydraulic separator | |
| 21 Isolation valve | |
| 22 Check valve | |
| 23 Delivery to the central heating system | |

10.4 - MYDENS boiler

INAIL safety devices

The boiler is supplied as standard without the INAIL safety devices.

WARNING! All boilers of more than 35 kW of power must, at the installer's responsibility, be equipped with safety devices as provided for by Compilation "R" issued by the INAIL.

WARNING! Isolation devices must not be installed between the boiler and the safety valve (detail "7" in figure 10-3 and "15" in figure 10-4).

To make installation convenient, COSMOGAS supplies, on request, INAIL kits complete with required devices and the segment designed to house them.

In figure 10-3 the kit for models 70T and 140T.

Figure 10-3 Key

- 1 = Nipple
- 2 = Gasket
- 3 = Manifold
- 4 = Catch basin for sensor Valve "11"
- 5 = INAIL thermometer
- 6 = INAIL pressure gauge
- 7 = INAIL safety valve
- 8 = Connection group
- 11 = INAIL fuel isolation valve
- 12 = Inspection basin
- 13 = INAIL safety thermostat
- 14 = INAIL safety pressure switch
- 15 = INAIL safety pressure switch
- 16 = Expansion tank connection joint

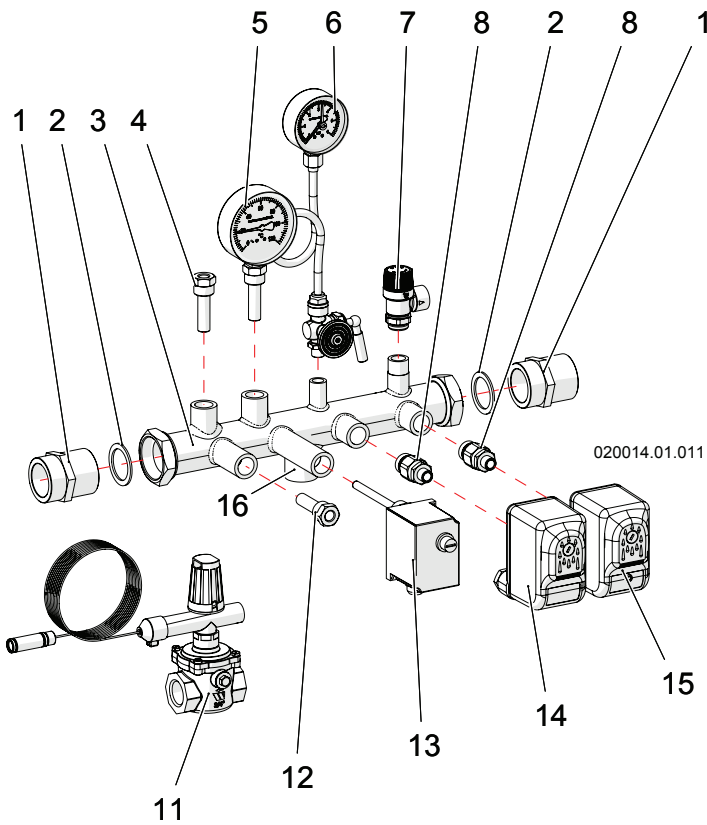

Figure 10-3 - INAIL KIT for 70T to 140T

WARNING! The sensor of valve "11" (figure 10-3) is positioned in the basin for sensor "4" and closed with the relative anti-unthreading locking screw.

In figure 10-4 the kit for models 210T and 280T

Figure 10-4 Key

- 1 = Fixing nuts and bolts
- 2 = Gasket
- 3 = INAIL safety pressure switch
- 4 = INAIL safety pressure switch
- 5 = Connection group
- 6 = INAIL safety thermostat
- 7 = Manifold
- 10 = INAIL fuel isolation valve
- 11 = Catch basin for sensor Valve "10"
- 12 = Inspection basin
- 13 = Expansion tank connection joint
- 14 = INAIL pressure gauge
- 15 = INAIL safety valve
- 16 = INAIL thermometer

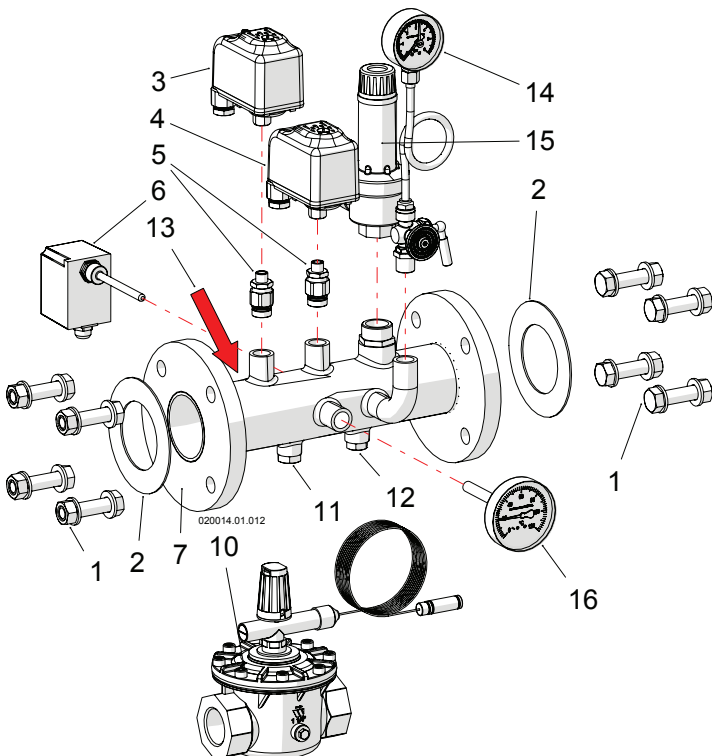

Figure 10-4 - INAIL KIT for 210T to 280T

WARNING! The sensor of valve "10" (figure 10-4) is positioned in the basin for sensor "11" and closed with the relative anti-unthreading locking screw.

10.5 - Connection of expansion tank



WARNING! The boiler has no expansion tank. Provide the system with an expansion tank of a suitable size, as laid out in national and local installation regulations.

10.6 - Delivery and return



WARNING! COSMOGAS is not liable for any damage caused by incorrect use of additives in the central heating system.



WARNING! The system after the appliance must be made with materials that resist temperatures up to 97°C and pressure of 11 bar. Otherwise (e.g. with plastic piping), the system must be fitted with the relevant protection and safety devices.

Before connecting the plumbing, wash the system thoroughly to eliminate any waste (hemp, radiators casting sand, etc.), which could damage the appliance. This must also be performed if the appliance is replaced.

In figures 8-1 and 8-2 you can check the positioning of the delivery and return connections.

☞ Install a metal mesh filter on the return pipe with passage of 1 mm² in order to trap any system residues before they return to the boiler.

☞ Do not use the appliance to introduce any type of additive into the system.

10.7 - MYDENS boiler water supply



WARNING! The connection of the system (and therefore the boiler) to the water mains must be completed with the insertion between them of a device that prevents backflows to the drinking water system, as required by the anti-pollution safety regulations in force.

10.7.1 - Recommendations on characteristics of water in the system

Filling the central heating system is an extremely delicate operation that should not be underestimated, either in cases of just replacing the heat generator or in when a new appliance is installed. Incorrect assessment of the characteristics of the system's water can lead, in some cases, to damage to the system and heating unit. A system is almost never perfectly sealed; sometimes there may be water leaks and oxygen can also get in; both these phenomena cause damage.

Among the parameters that can have a negative impact on the lifetime of a system, the following are the main ones:

- The simultaneous presence of different metals (copper, brass, steel and aluminium) which, in an aqueous environment, give rise to galvanic corrosion.

- The presence of free oxygen, due to air infiltration which may occur near to joints or seals, constitutes a typical corrosive agent, particularly active at temperatures between 50 and 70° C.

- Water leakage, which leads to frequent refills, can cause corrosion or limescale, depending on the type of water available for the fillings. In all cases all of the leaks (and relative refills) must be kept under control, especially when an automatic filling system is installed. In this case it is definitely

recommended that a meter be installed which can indicate the quantity of water replenished.

Natural or added impurities in the water. A lot of drinking water can contain concentrations, which may be significant, of chlorides and sulphates that can increase the speed of corrosion of metallic surfaces. Other undesirable components could have been introduced into the system before or during installation (building materials, metallic chips, shavings, grease, deposits and dirt in general). Residues from welding can also cause corrosion, both in new systems and after modifications and repairs. In old systems planned to work with radiators, characterised by pipework with a very large diameter, the water content of the system is significant and fosters the formation of dirt and deposits.

Dirt and Limescale The presence of black deposits (magnetite) indicates that there is limited corrosion, however, the high specific weight of this oxide can cause blockages that are hard to remove, especially in the hottest areas. Limescale is due to the hardness of the water, or to the presence of calcium and magnesium salts. Calcium, in the form of calcium carbonate, is deposited in the hottest areas of the system. Magnetite often contributes to consolidating the limescale. On the other hand, iron oxide (the water has a reddish colour) is an indicator of corrosion from oxygen.

Frequent leaks. Where there are frequent leaks the hydrogen and/or air accumulate on the top part of the heat exchanger and radiators, preventing full exchange of heat. When the electrolytic corrosion process has begun, the water level in the system is lowered, gases accumulate in the top part of the heat exchanger and radiators. The presence of air is caused by the fact that the system might not be perfectly sealed. A slow drop in system pressure due to a leak is often difficult to find, especially when the leak is minimal (in winter leaks from radiator valves sometimes are not visible because they are dried by the heat produced by the radiator or boiler). These micro-leaks do, however, allow air to get into the system. The main points that micro-leaks can develop are at the joints and, in particular, on the intake side of the pump (air vent valve, seals with O-rings, fill valves). In these cases, to avoid damage, the system must be protected with a suitable corrosion inhibitor.

10.7.2 - For correct operation of the system make sure that:

- 1) the system has no leaks or at least the most obvious leaks have been repaired;
- 2) if there is an automatic filling system, a litre counter must have been installed so as to know the exact quantity of any leaks;
- 3) filling the system and refilling is done with softened water so as to reduce its overall hardness. The water **must** also be conditioned in order to keep the pH within the threshold set so as to avoid corrosion;
- 4) Both on new systems and system replacements there must be efficient systems to get rid of air and impurities; filters, micro-impurity separators and micro air bubble separators;
- 5) Avoid discharging water from the system during normal maintenance operations, even if it is apparently insignificant quantities: for example when cleaning filters, equip the system with the relevant isolation valves up and down stream from the filter itself;
- 6) Always carry out an analysis of the system water before opening communication between a new boiler and the system, to establish whether the chemical and physical properties of the water indicate the need to carry out complete emptying of the system, the use of the water already in the system or chemical washing of the system, using mains water with the addition of a detergent, when there is a suspicion that

10 - INSTALLATION - Plumbing connections - MYDENS boiler

the system may be dirty or particularly blocked up, and the subsequent refilling with new treated water.

If the analysis of a sample of water that will be used to fill the system shows the following values:

- Hardness from 12 °F to 20 °F
- $7.5 < \text{pH} < 9.5$

then you can proceed with filling. If the properties are different, an inhibitor must be used.

10.7.3 Water treatment in domestic heating systems

The water in domestic heating systems must always be treated both when the boiler is replaced and when it is a new system. All the treatment systems and chemical conditioning processes required must be set up during the planning stage, based on the characteristics of the unrefined water, in order to obtain water with the following characteristics:

- Appearance: clear, colourless and with no foam;
- pH: from 7.5 to 9.5;
- Hardness from 12 °F to 20 °F;
- Conditioners: present within the concentrations laid down by the *supplier*.

If the water characteristics are unknown, there is a very high probability of running into problems such as the following:

a. LIMESCALE

$30^\circ \text{fr} = 300 \text{ mg/kg CaCO}_3$

For a system that contains 1000 litres of water at 30°f the content of CaCO_3 is 300 gr, which, if not suitably treated, will be deposited on the surface of the heat exchanger (as it is the hottest part of the system). This creates concentrated increases in temperature and consequently causes the heat exchanger to break.

b. CORROSION

As a rule corrosion is fostered by the presence of oxygen, by contact between different metals, or by the presence of chlorides.

c. DEPOSITS

These are insoluble organic and inorganic substances: DIRT, RESIDUES FROM WORK.

10.8 - MYDENS boiler heat circuit outlet

In order to avoid constantly refilling with water and the resultant introduction of oxygen and limescale, it is advisable to limit as much as possible any work of draining the heating circuit.

10.9 - MYDENS boiler low-temperature systems (or underfloor heating)



WARNING! If the boiler is installed in an underfloor system made with plastic piping, all of the necessary precautions must be taken against corrosion due to oxygen in the water:

make sure that the system is made with plastic pipes with oxygen permeability not exceeding 0.1 g/m^3 at 40°C . Should the pipe not meet these characteristics, the radiant panel circuit must be isolated from the boiler, via a plate heat exchanger suitable for resisting the corrosion generated by the oxygen dissolved in the water.

10.10 - Manifold sensor

The manifold sensor (detail 26 in figures 3-3, 3-5 and 3-7), is fitted at the factory onto the boiler manifold. However, this position may not be correct in certain systems with a hydraulic separator or a plate heat exchanger (see figures 10-1 and 10-2). It is therefore recommended that the sensor be removed from the boiler manifold to the hydraulic separator as shown in figures 10-1 and 10-2, at detail 58.



WARNING! For correct operation of the system the manifold sensor must be located at a point on the hydraulic separator/plate heat exchanger where it can detect the correct delivery temperature and can be influenced by the temperature of the secondary circuit water flow

10.11 - MYDENS boiler characteristic curve of head losses

MYDENS model boilers do not have a circulation pump. For the size of the pumps to be used, the designer must consider the system's hydraulic resistances and the hydraulic resistances of the boiler itself. For this purpose the hydraulic resistance of the boiler is shown in figure 10-5 in the form of a graph.

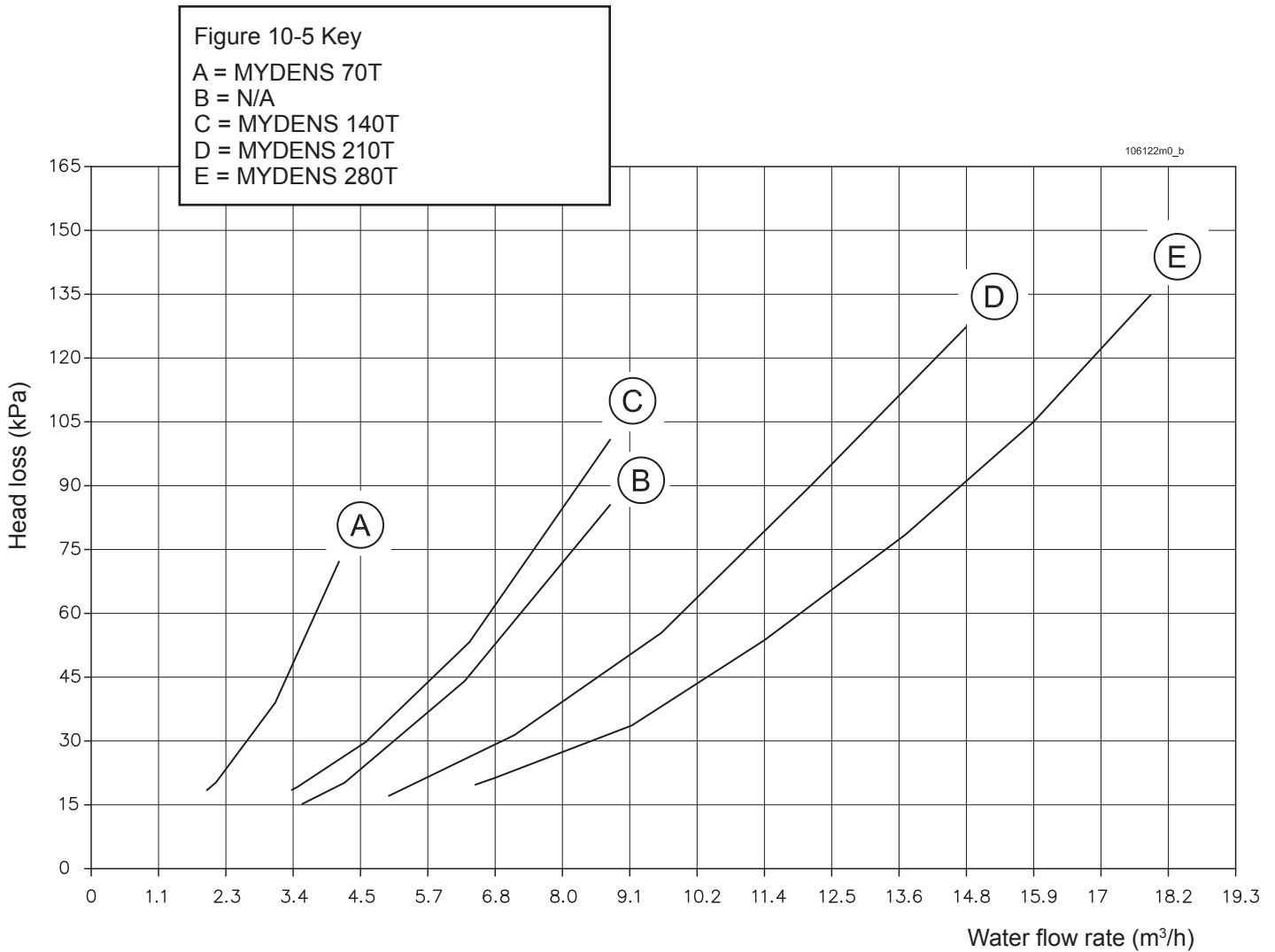



Figure 10-5 - Hydraulic resistances of MYDENS models "70T-280T"

11 - INSTALLATION - Plumbing connections - AGUADENS hot water heater

11.1 - AGUADENS hot water heater plumbing and gas connections

 **WARNING!** Use trolleys suitable for the type of boiler to move it. Not doing this could cause serious harm.

To identify the position of the connections, see figures 9-1 and 9-2.

Gas connection

Connecting to the gas must be made to the relative attachment with a rigid metal pipe. The capacity of the gas meter must be adequate for the simultaneous use of all the gas boilers connected to it. Connect the boiler to the gas, as required by the regulations in force. The diameter of the gas pipe that comes out of the boiler, is not a determining factor when choosing the diameter of the pipe between the boiler and the meter; it must be chosen according to its length and to head losses.

 **WARNING!** It is recommended that a gas isolation valve should be installed immediately before the boiler, in order to allow the gas supply to be interrupted.

 **WARNING!** Do not power the appliance with gases other than those specified.

11.2 - AGUADENS hot water heater safety valve (responsibility of the installer)

The boiler is supplied with no safety valve against too high pressure, so that the installer is able to choose the valve that suits the system's operating pressure (check the operating pressure of the boiler in the technical data section). The installation must be carried out in such a way as to allow the user to check it has intervened when the valve is opened. The safety valve outlet (responsibility of the installer) must be orientated in such a way as to avoid danger for people if it intervenes.

 **WARNING!** If you do not route the safety valve, it might cause harm to people, animals or things if it has to intervene.

11.3 - AGUADENS hot water heater examples of installation

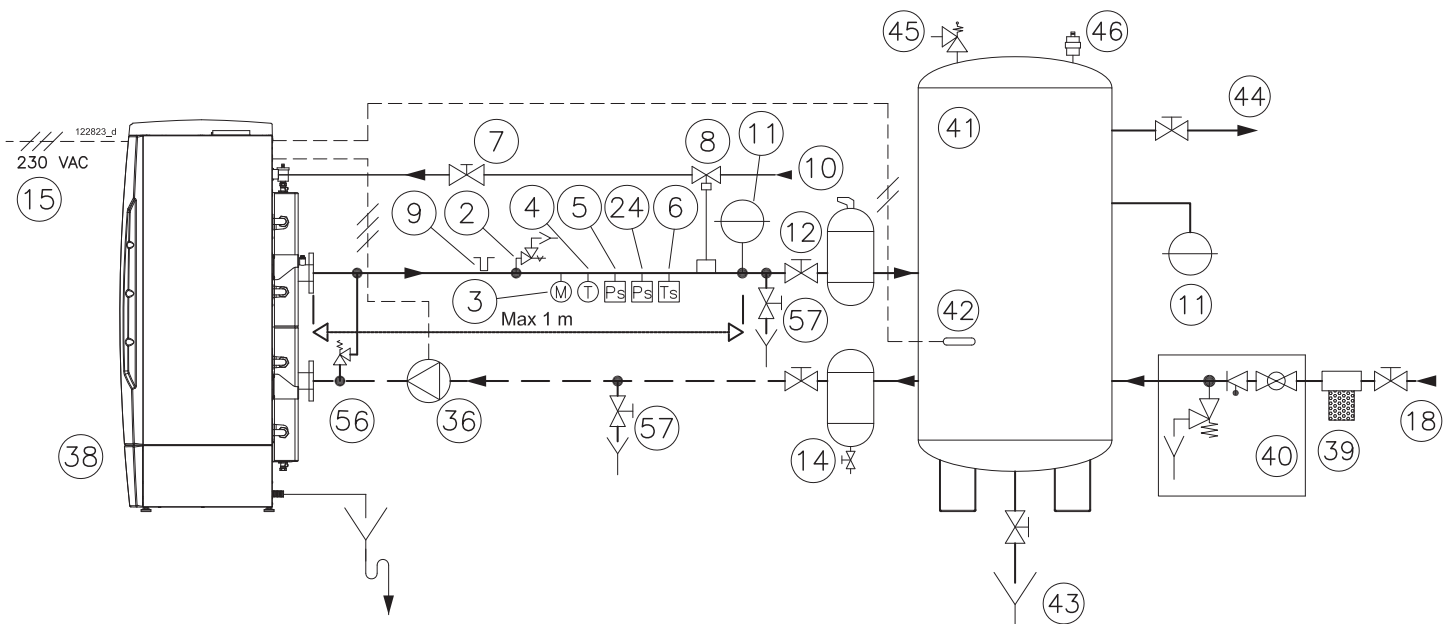

Figure 11-1 - AGUADENS example of connection diagram

- | | |
|---|---|
| 2 INAIL safety valve | 36 DHW circuit pump |
| 3 INAIL pressure gauge | 38 AGUADENS model 60T-280T hot water heater |
| 4 INAIL thermometer | 39 Polyphosphate salts softener |
| 5 INAIL maximum safety pressure switch | 40 Hydraulic safety unit (EN 1487) |
| 6 INAIL safety thermostat | 41 Storage tank |
| 7 Gas cock | 42 Storage tank probe |
| 8 INAIL Gas isolation valve | 43 Storage tank outlet valve |
| 9 INAIL basin | 44 DHW outlet |
| 10 Gas inlet | 45 Storage tank safety valve |
| 11 Expansion tank | 46 Storage tank air vent valve |
| 12 Microbubble separator | 56 Balancing valve (necessary if there is in the boiler the motorised valve, detail "17" in figure 3-1 and pump "36" is NOT the modulating type) |
| 14 Filter | 57 - Drain cock |
| 15 Electric power supply | |
| 18 Cold DHW | |
| 23 ----- | |
| 24 INAIL minimum safety pressure switch | |

11.4 - AGUADENS hot water heater INAIL safety devices

The boiler is supplied as standard without the INAIL safety devices.

WARNING! All hot water heaters of a power greater than 35 kW when combined with a puffer tank must meet the requirements of Compilation R issued by the INAIL.

WARNING! Isolation devices must not be installed between the boiler and the safety valve (detail "7" in figure 11-2 and "15" in figure 11-3). To make installation convenient, COSMOGAS supplies, on request, INAIL kits complete with required devices and the segment designed to house them.

Figure 11-2 shows the INAIL kit for models 70T and 140T. Figure 11-2 Key

- 1 = Nipple
- 2 = Gasket
- 3 = Manifold
- 4 = Catch basin for sensor Valve "11"
- 5 = INAIL thermometer
- 6 = INAIL pressure gauge
- 7 = INAIL safety valve
- 8 = Connection group
- 11 = INAIL fuel isolation valve
- 12 = Inspection basin
- 13 = INAIL safety thermostat
- 14 = INAIL safety pressure switch
- 15 = INAIL safety pressure switch
- 16 = Expansion tank connection joint

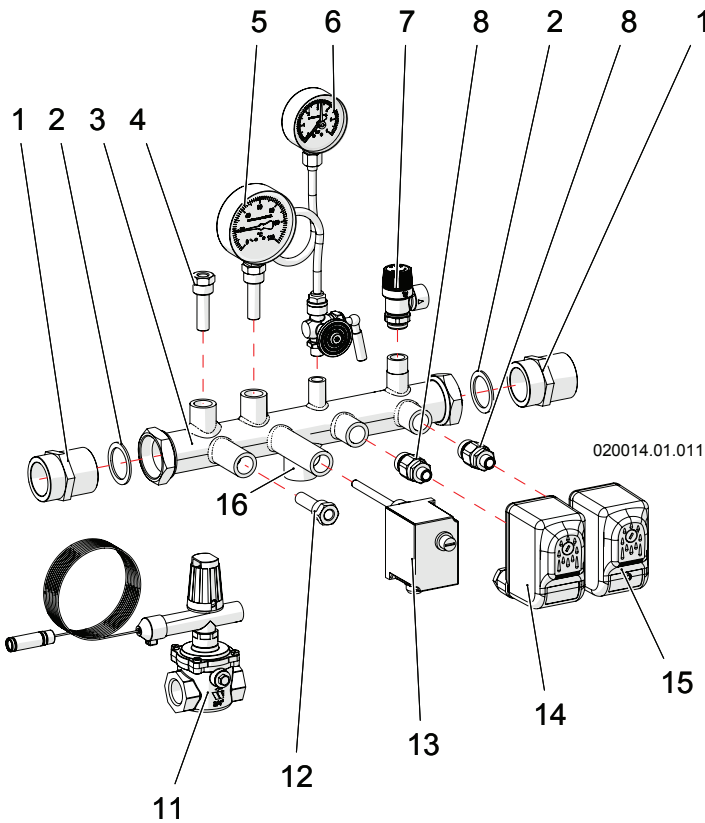

Figure 11-2 - INAIL KIT for 70T to 140T

WARNING! The sensor of valve "11" (figure 11-2) is positioned in the basin for sensor "4" and closed with the relative anti-unthreading locking screw.

Figure 11-3 shows the INAIL kit for models 210T and 280T. Figure 11-3 Key

- 1 = Fixing nuts and bolts
- 2 = Gasket
- 3 = INAIL safety pressure switch
- 4 = INAIL safety pressure switch
- 5 = Connection group
- 6 = INAIL safety thermostat
- 7 = Manifold
- 10 = INAIL fuel isolation valve
- 11 = Catch basin for sensor Valve "10"
- 12 = Inspection basin
- 13 = Expansion tank connection joint
- 14 = INAIL pressure gauge
- 15 = INAIL safety valve
- 16 = INAIL thermometer

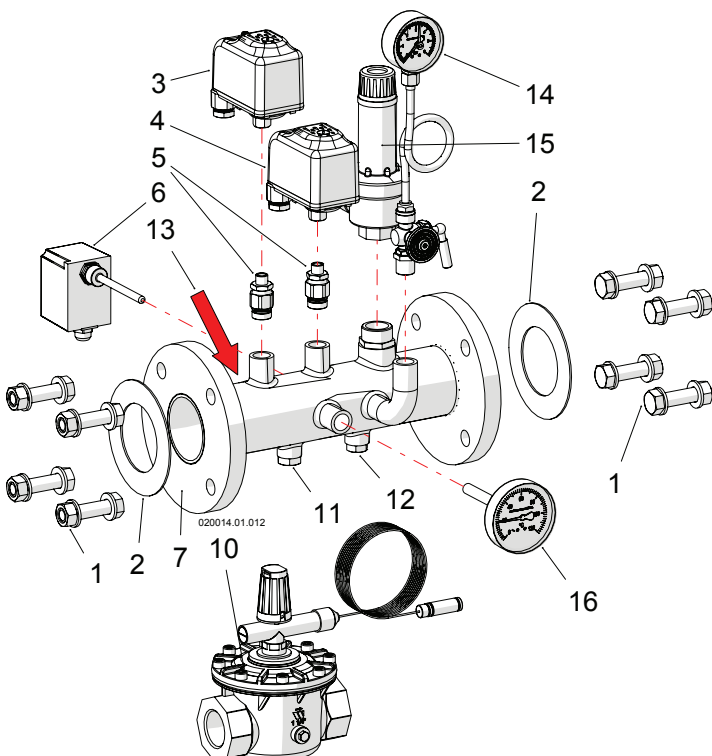

Figure 11-3 - INAIL KIT for 210T to 280T

WARNING! The sensor of valve "10" (figure 11-3) is positioned in the basin for sensor "11" and closed with the relative anti-unthreading locking screw.

11 - INSTALLATION - Plumbing connections - AGUADENS hot water heater

11.5 - Expansion tank

Set up a thermal expansion control system such as an expansion tank. Make sure that the expansion tank is the right size for the volume of water contained in the hot water heater and the system (see section 19 heading "Water content in primary heat exchanger"), also taking into account the temperature and working pressure.



WARNING! The boiler has no expansion tank. Provide the system with an expansion tank for domestic hot water circuits of a suitable size, as laid out in national and local installation regulations. Underestimating the size of the expansion tank can cause the safety valve to intervene.

The expansion tank must be installed as shown in figure 11-1 or according to recognised planning methods. Refer to the expansion tank manufacturer's instructions for further details about installation.

11.6 - Circulation pump

This hot water heater must always be linked to a storage tank of a size of not less than 1 litre per kW of power installed. A domestic hot water circulation pump must be installed to fill the storage tank. The hydraulic resistance of the hot water heater is shown in the form of a graph in figure 11-4.

For the correct sizing of the pump, the designer must take into account the resistance of the hot water heater, the resistance of the storage tank and the resistance of the connection system. For the electrical collection refer to figure 13-6.

If the pump selected has absorption of more than 3 A, insert a support relay between the hot water heater and the pump.

11.7 - Size of system

Size the pump, the pipes and any device needed by the system using a recognised planning method.



WARNING! It is the installer's responsibility to ensure that the minimum water flow rate to the hot water heater is never, at any moment, lower than that shown in the following table:

MODEL	UM	VALUE
70T	m ³ /h	3.3
140T	m ³ /h	6.6
180T	m ³ /h	9.9
280T	m ³ /h	13.2

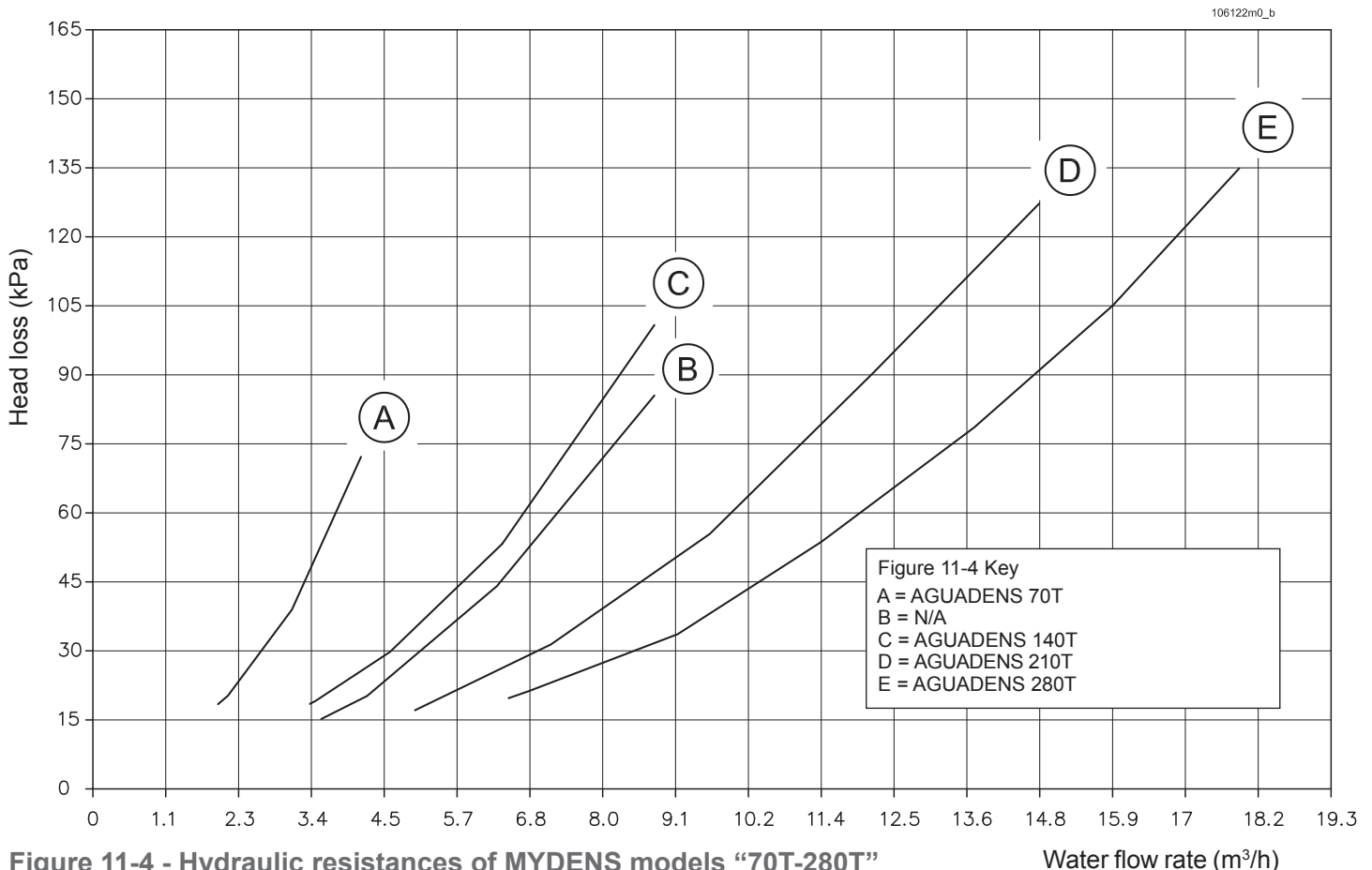

Figure 11-4 - Hydraulic resistances of MYDENS models "70T-280T"

Water flow rate (m³/h)

11.8 - Precautions against scalds



WARNING! This hot water heater can supply water at a temperature of up to 80°C. When you are using the water heated by the hot water heater you must take care to avoid scalds.

Some domestic appliances such as automatic dishwashers and washing machines may require the water temperature to be increased. Setting the hot water heater to provide water at the higher temperature demanded by these domestic appliances does lead to the risk of scalds. To avoid this hazard, safety devices to reduce the water temperature and prevent the risk of scalds must be installed upstream from the users of the domestic hot water.

11.9 - Water quality



WARNING! If the hardness of the water is higher than 20°F (200 mg/l), a water softener must be installed on the cold water inlet.



WARNING! If the hot water heater has to work at temperatures above 60°C, the hardness of the water must be less than 15°F (150 mg/l).



WARNING! The water must not be softened to values lower than 5°F (50 mg/l). At these values it becomes acidic and can corrode parts of the hot water heater, shortening its life.



WARNING! The acidity of the water must have a pH value between 6.5 and 8.5. A value outside this range is corrosive and can cause damage to the heat exchanger and/or pipes.



WARNING! Install a filter with mesh no wider than 0.5 mm² in the domestic cold water inlet.



WARNING! The domestic hot water circuit must be made with materials resistant to temperatures of at least 95°C and a pressure of 10 bar. Otherwise (e.g. with plastic piping), the system must be fitted with the relevant protection and safety devices.

12 - INSTALLATION - Disposal of condensate

12.1 - Condensate outlet

The boiler has inside it a siphon system and condensate neutraliser to evacuate condensates (see figures 3-3, 3-5 and 3-7, details "2" and "3") and prevent combustion products from escaping, the end of which meets duct "5" in figures 3-3, 3-5 and 3-7. This end must be funnelled into another anti-odour siphon (responsibility of the installer) so as to prevent bad smells from coming back into the room.

In particular, the condensate outlet system must:

- ☞ be performed with a pipe with an internal diameter equal to or greater than 13 mm;
 - ☞ be installed in such a way as to prevent the liquid from freezing; therefore pay attention to any external sections. It is prohibited to drain into gutters or rainwater drainpipes;
 - ☞ slope continuously towards the drain point; avoid high points, which could pressurise the pipe;
- Figure 12-2 shows how a condensate disposal system must be created downstream from the boiler.

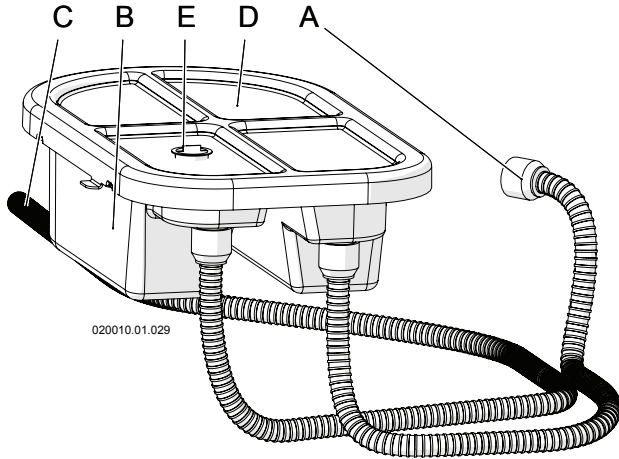

Figure 12-1 - Condensate neutraliser

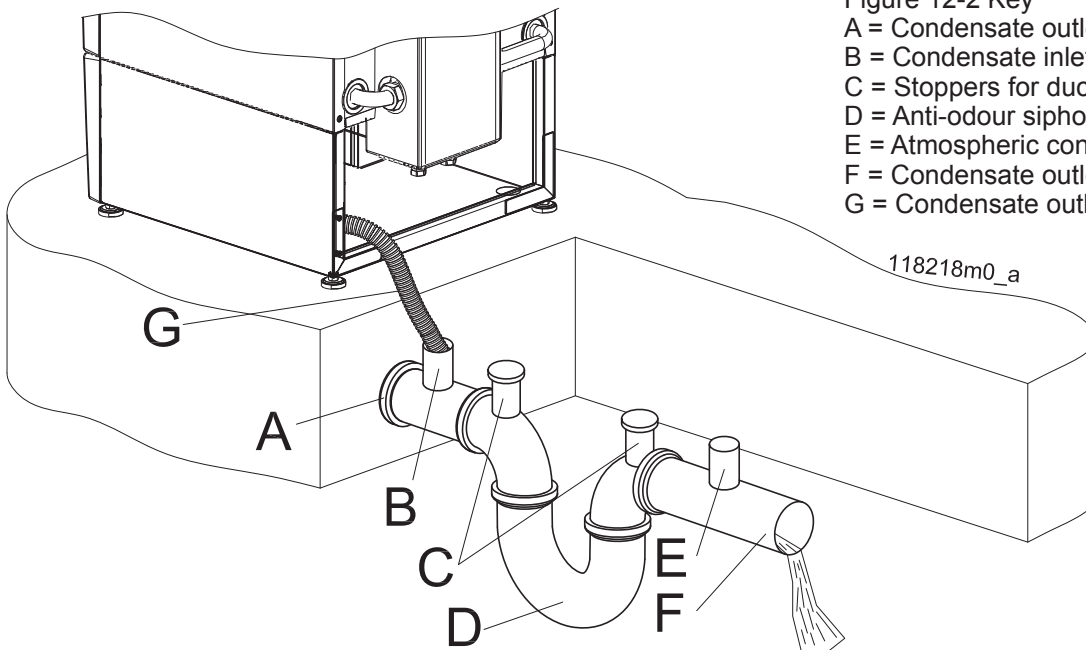

Figure 12-2 Key

- A = Condensate outlet duct start stopper;
- B = Condensate inlet;
- C = Stoppers for duct inspection;
- D = Anti-odour siphon system;
- E = Atmospheric connection (duct vent);
- F = Condensate outlet;
- G = Condensate outlet pipe;

Figure 12-2 - Condensate outlet

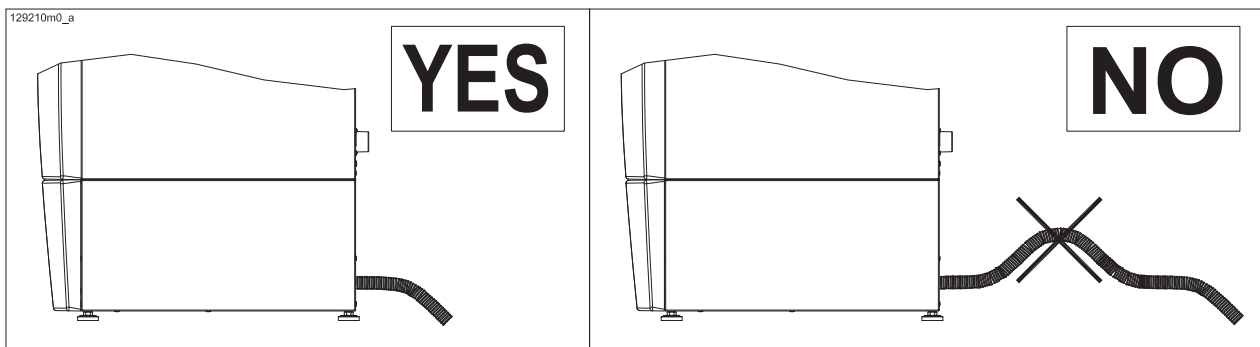





Figure 12-3 - Correct installation of condensate outlet pipe

13 - INSTALLATION - Electrical connections





13.1 - Electrical connections: details

 **WARNING!** Disconnect the electric power supply before carrying out any intervention inside the boiler.

 **WARNING!** During maintenance label all the cables being examined before disconnecting them.

 **WARNING!** The appliance is only electrically safe when it has been correctly connected to an efficient earth circuit, performed as provided for by the current safety regulations.

This fundamental safety requirement must be met. If in doubt, request a thorough check of the electrical system by a professionally qualified technician.

-  Have a professionally qualified technician check that the electrical system is suitable for the electric power required by the appliance, as indicated on the plate.
-  The use of adapters, multiplugs, extension leads, etc. is not permitted.
-  The boiler must be connected to the mains power supply with a triple-pole dual insulation cable of a suitable section.
-  For connection to mains electricity, a two-pole switch must be installed near the appliance with a contact opening distance of at least 3 mm, as envisioned by the current sector regulations.

 Respect the polarity between the neutral and phase wires when connecting the appliance.

 Make sure that the water, central heating and gas system pipes are not used as earths for the electrical or telephone system. This piping is not suitable for this purpose; serious corrosion damage would occur in a very short time to the appliance, piping and radiators.

 **WARNING!** The boiler has no protection against the effects of lightning strikes.

13.1.1 - Connecting power supply cable

To connect the power supply cable proceed as follows (refer to Figure 13-1):

- 1.- use a triple-pole dual insulation cable
- 2.- access the electrical connections terminals following the relevant instructions in section 18.2;
- 3.- lay the power supply cable through the cable gland next to contacts "101", "102" and "PE";
- 6.- remove the sheathing from the cable, taking care to keep the earth wire (yellow/green) 20 mm longer than the other two;
- 7.- connect the yellow-green cable to the earth terminal ("PE");
- 8.- connect the brown cable (Live) to terminal "101"
- 9.- Connect the blue cable (Neutral) to terminal "102"

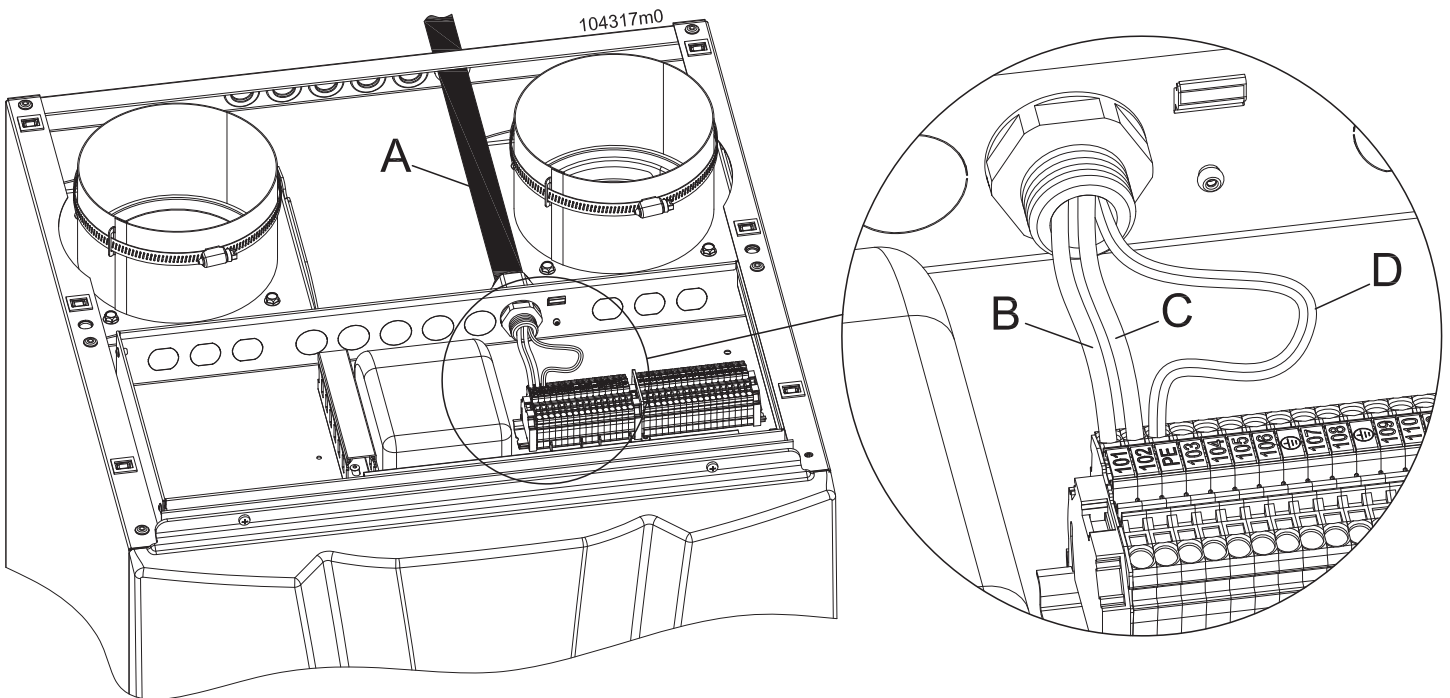

KEY

- A = Electric cables sheath;
- B = Line;
- C = Neutral;
- D = Earth.

Figure 13-1 – Electrical connections

13 - INSTALLATION - Electrical connections

13.1.2 – Choosing the room thermostat/chronothermostat

The boiler is set up to operate with any room thermostat or chronothermostat which has the contact to which the cables from the boiler can be connected, with the following features:

- open/closed (ON/OFF);
- potential-free (not powered);
- closing, when there is a request for heat;
- 24VAC, 1A.

13.1.3 - Connecting the room thermostat/chronothermostat

Install the room thermostat in a place in the house where the temperature is most typical for the home and in an area that is **not** vulnerable to sudden temperature changes, away from windows or doors which open directly to the outside (see figure 13-2).

Proceed as follows to connect the room thermostat cable (refer to figures 13-4 and 13-5):

- 1.- Use a two-pole cable, with a minimum cross-section of 1.5 mm², from the boiler to the room thermostat/chronothermostat. The maximum length allowed is 100 metres. Use a shielded cable with shield earthing;
- 2.- Remove the casing from the boiler, following the relevant instructions in section 18.2;
- 3.- Lay the electric cable through the fairlead near contacts "10" and "11";
- 4.- Use a free fairlead, not used by other wires;
- 5.- Strip the cable;
- 6.- Connect the two ends of the cable to terminals "10" and "11" (see figures 13-4 and 13-5).



WARNING! As the room thermostat/chronothermostat cables are subjected to a very low safety voltage (24 VDC), they must flow in ducts other than those supplying 230 VAC power.

13.1.4 - Installing the outdoor temperature sensor

Install the outdoor temperature sensor outside the building on a wall facing NORTH or NORTH-EAST, at a height of between 2 metres and 2.5 metres from the ground. For buildings with several floors, it must be installed at about half way up the second floor. Do not install it above windows, doors or ventilation outlets or directly below balconies or gutters. Do not plaster over the outdoor temperature sensor. Do not install the sensor on walls without eaves, i.e. where not protected from rain.

Where the sensor is installed on a wall that has yet to be plastered, it must be installed with a suitable thickness or be removed before plastering.

Proceed as follows to connect the outdoor temperature sensor cable:

- 1.- Lay a two-pole electric cable with a minimum cross-section of 1.5 mm², which goes from the boiler to the outdoor temperature sensor. The maximum length allowed is 100 metres. Use a shielded cable with shield earthing.



WARNING! As the cables are subjected to a very low safety voltage (24 VDC), they must flow in wires different from the 230 VAC power supplies.

- 2.- Connect the two-pole cable to terminals "14" and "15" in figures 13-4 and 13-5;
- 3.- Connect the bipolar cable to the ends of the outdoor temperature sensor.

Set the boiler to learn from the outdoor temperature sensor as follows:

- 4.- Go into the "installer menu" as described in section 17.15 and set parameter **2003 = 1**.

To confirm that the external sensor has been enabled, the  icon shows on the display.

Proceed with the steps given in section 17.9.1 to set the correct adjustment values for the supply temperature, according to the outdoor temperature.

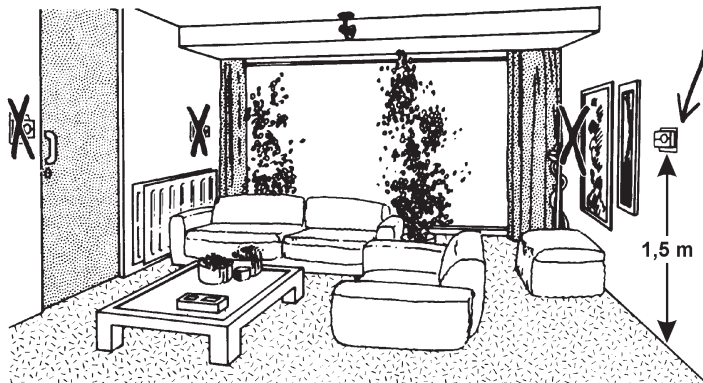

Figure 13-2 – Correct positioning of the room thermostat/chronothermostat

13 - INSTALLATION - Electrical connections

13.1.5 - Connection board 885 IF (on request)

Board 885 IF is supplied on request for all models (see detail "13" in figures 3-3, 3-5 and 3-7).

The board enables:

- 1.- control of boilers via 0-10 Vdc analogue signal;
- 2.- control of boilers via digital signal by MODBUS communication;
- 3.- cascade connection of boilers up to a number of 8 units (see section 13.4)

0-10 Vdc type dialogue (on request)

Board 885 IF allows the boiler to be controlled through 0-10 Vdc dialogue proceeding as shown below:

- 1.- Install the board as required by the instructions provided;
- 2.- Go into the "installer menu" as described in section 17.15 and set parameter **2003** = 4;
- 3.- Now the boiler can be controlled via the 0-10 Vdc signal according to the rules shown in figure 13-3;

MODBUS type dialogue (on request)

Board 885 IF allows the boiler to be controlled through MODBUS dialogue proceeding as shown in the instructions supplied on request:

13.1.6 - Alarm contact

The alarm contact only works if the 885 IF board is fitted (see figures 3-3, 3-5, 3-7 detail "13") and solely reflects the status of burner 1 (Master). In the event of one of the burners 2, 3 or 4 being blocked, it is not detected by the alarm contact.

13.2 - Connecting MYDENS boiler to storage tank

The MYDENS model boiler must be connected to a storage tank to produce domestic hot water.

The hydraulic connections must be made as per figure 10-2 or similar.

Proceed as follows for the electrical connections (refer to figures 13-4 and 13-5):

- 1.- Disconnect the electric power supply from the boiler;
- 2.- Lay a two-pole electric cable with a minimum cross-section of 1.5 mm², which goes from the boiler to the storage tank temperature sensor and connect it on the boiler to terminals "12" and "13" (SB);
- 3.- Connect the other end of the cable to the storage tank temperature sensor;
- 4.- Insert the temperature sensor probe inside the storage tank sample point (see figure 10-2, detail "31").
- 5.- Set parameter **3012** to value "1" (see section 20)
- 6.- electrically connect the storage tank pump to terminals "107" and "108" of the boiler (see figures 13-4 and 13-5).

The temperature of the water stored inside the storage tank can be selected by the user from a range of between 40°C and 60°C.



WARNING! A hot water temperature exceeding 51°C may cause permanent injury/damage to persons, animals and objects.

In particular, protect children, the elderly and people with disabilities against any possible risks of scalds, by inserting devices that limit the usage temperature of the DHW to users.

13.2.1 - Precedence to production of DHW

The boiler leaves the factory set with total precedence given to the production of domestic hot water. This means that the boiler operates in DHW mode until it reaches the temperature demanded by the storage tank connected. Because of this the aforementioned setting could lead to a cooling of the environment to be heated. Once the DHW demand has been satisfied, the boiler automatically goes back to working for the central heating circuit.

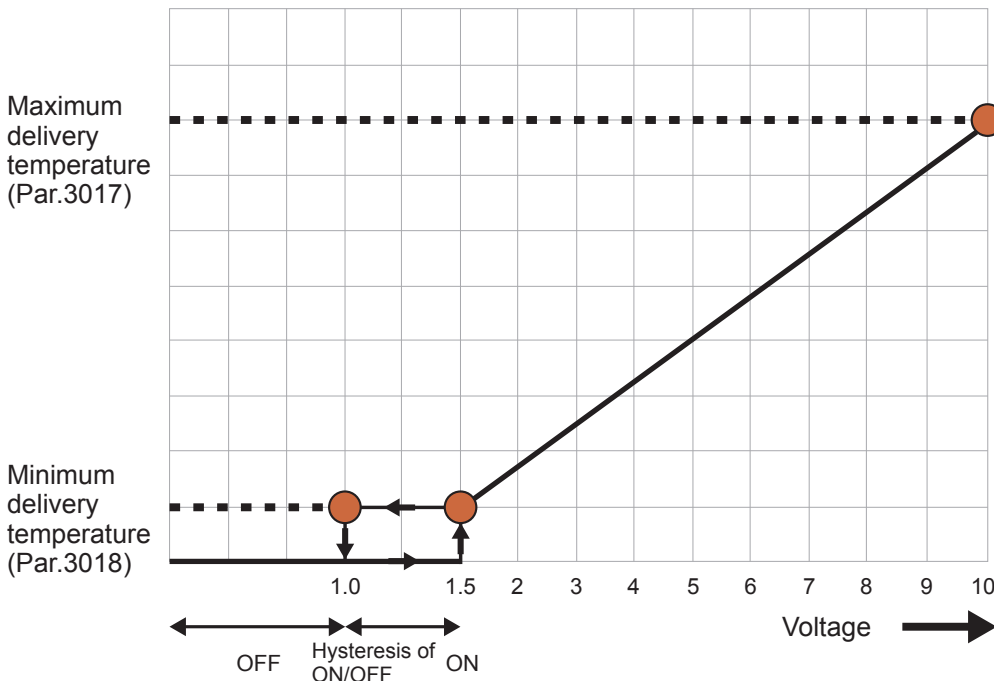

Figure 13-3 – Operating rules for 0-10 VDC analogue input
COSMOGAS

13.3 - Connecting AGUADENS hot water heater to storage tank

The AGUADENS model appliance must be connected to a storage tank.

The hydraulic connections must be made as per figure 11-1.



Proceed as follows for the electric connections (refer to figure 13-6):

- 1.- Disconnect the electric power supply from the boiler;
- 2.- Access the electric terminals for connection;
3. - Disconnect the manifold temperature sensor from terminals "8" and "9";
- 4.- Use the storage tank sensor which is supplied with the hot water heater and connect it to terminals "8" and "9".

Lay a two-pole electric cable with a minimum cross-section of 1.5 mm², which goes from the hot water heater to the storage tank temperature sensor and connect it to the hot water heater on terminals "8" and "9" (Manifold temperature sensor);

- 5.- Connect the other end of the cable to the storage tank temperature sensor;
- 6.- Insert the temperature sensor probe inside the storage tank sample point (see figure 11-1, detail "42").

The temperature of the water stored inside the storage tank can be selected by the user from a range of between 40°C and 80°C, using the commands to adjust the central heating

temperature  or , as shown in section 17.5.



WARNING! A hot water temperature exceeding 51°C may cause permanent injury/damage to persons, animals and objects. In particular, protect children, the elderly and people with disabilities against any possible risks of scalds, by inserting devices that limit the usage temperature of the DHW to users.

13 - INSTALLATION - Electrical connections

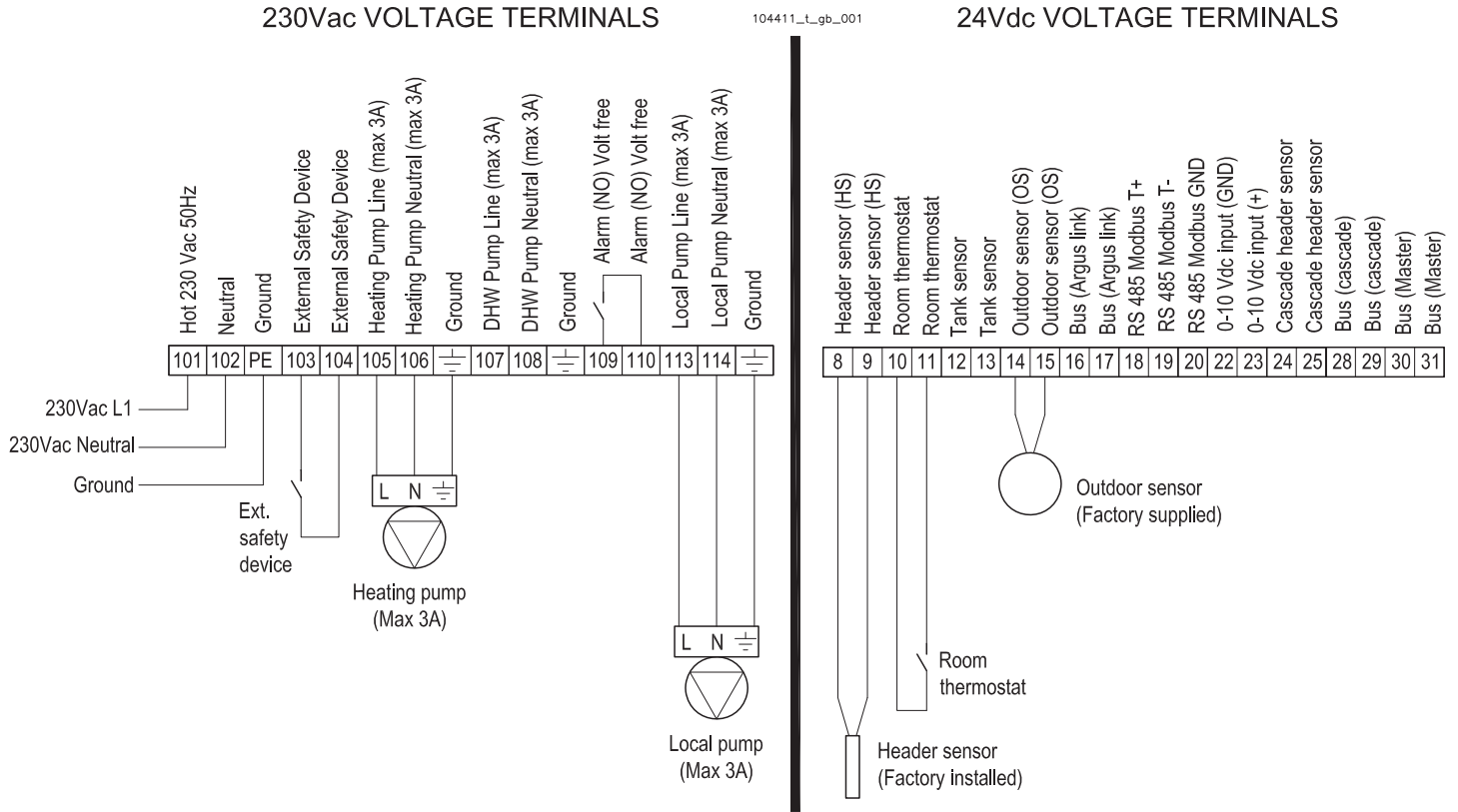

Figure 13-4 - MYDENS boiler electrical connections (Example of system shown in figure 10-1)

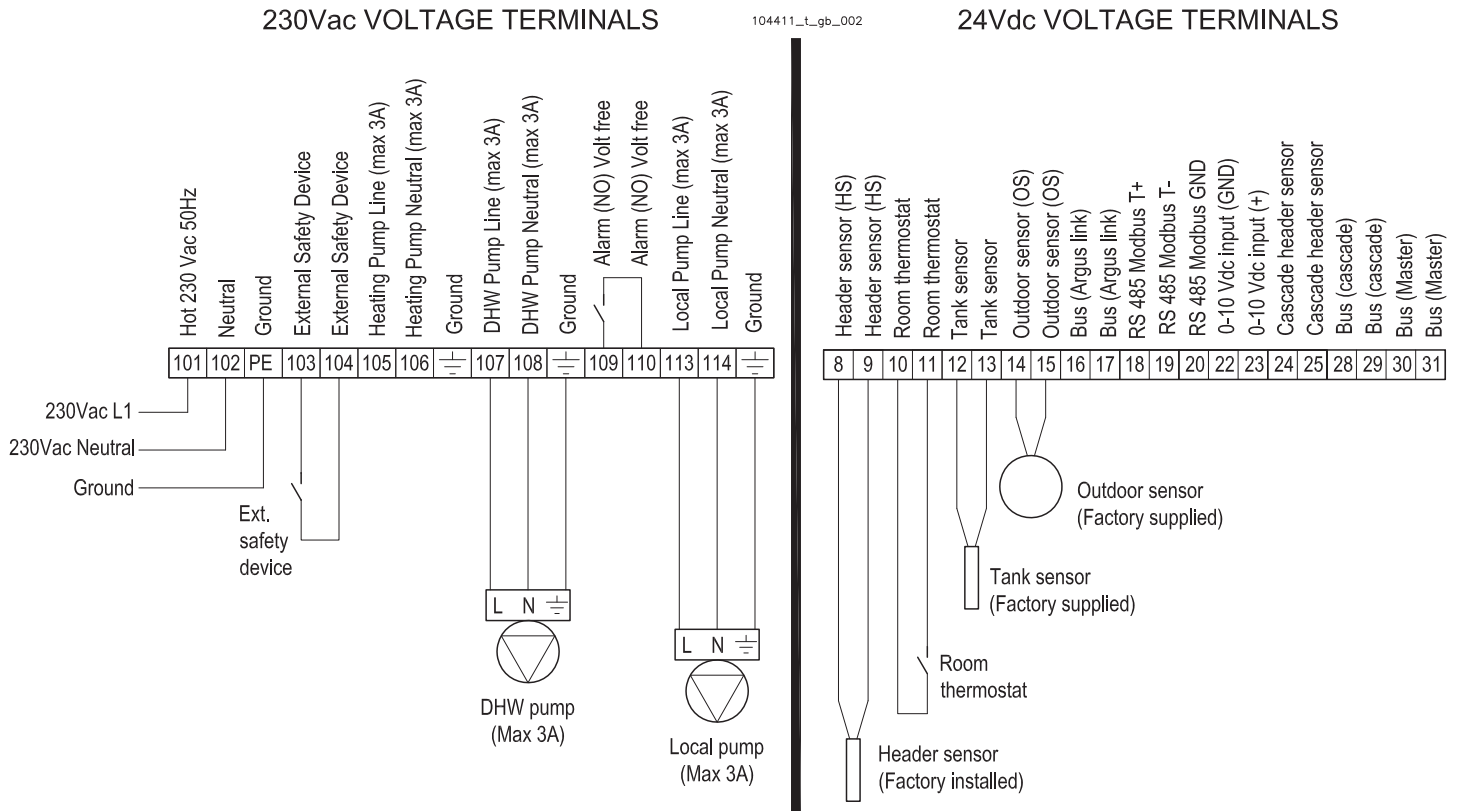

Figure 13-5 - MYDENS boiler electrical connections (Example of system shown in figure 10-2)

13 - INSTALLATION - Electrical connections

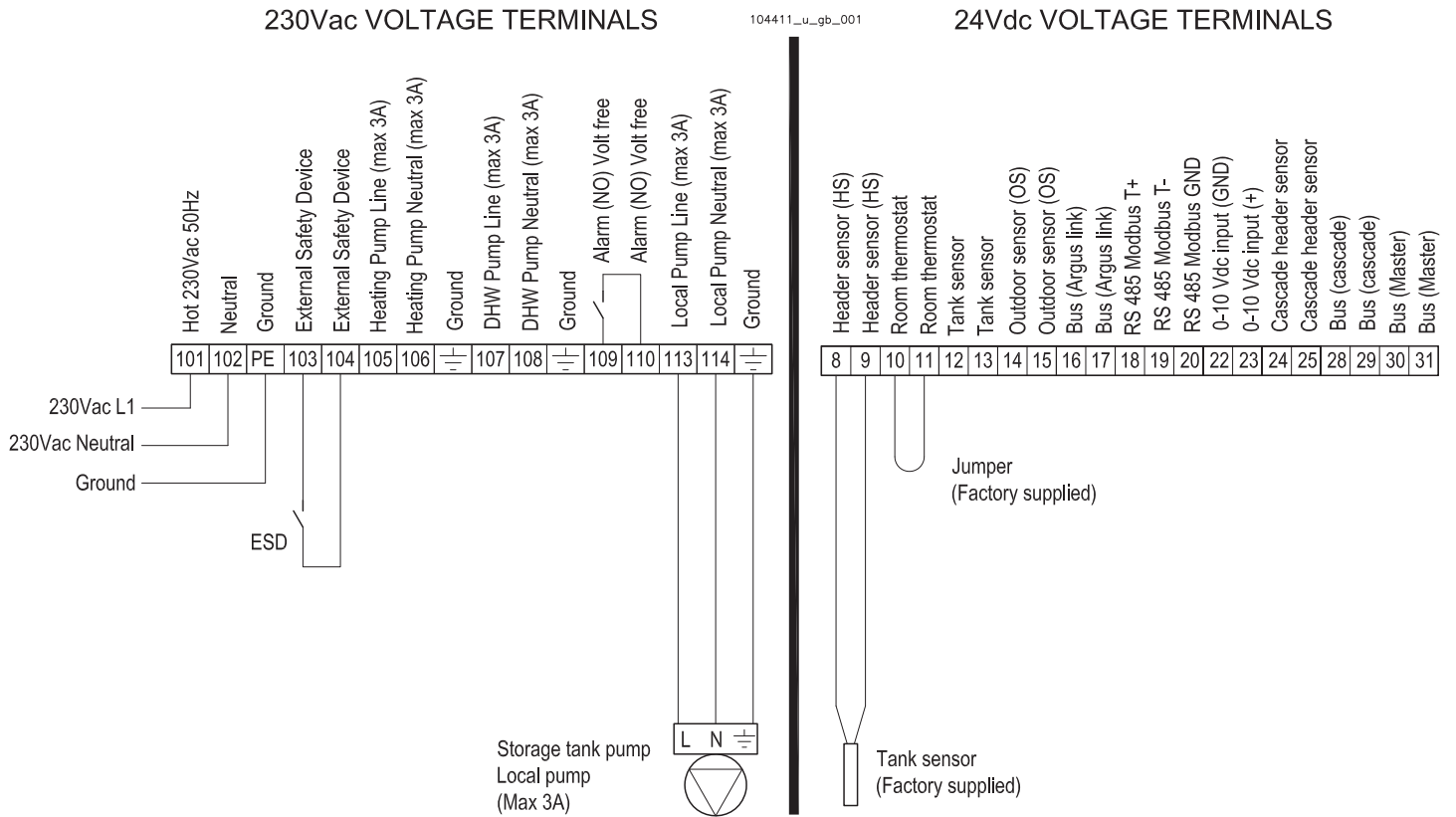

Figure 13-6 – AGUADENS hot water heater electrical connections
(Example of system shown in figure 11-1)

13 - INSTALLATION - Electrical connections

13.4 - Cascading appliances

Cascading appliances as shown in the diagrams in figures 13-7 (MYDENS) and 13-8 (AGUADENS).

It is necessary to first install the 885 IF board (detail "13" in figures 3-3, 3-5 and 3-7) in each appliance and acquire the cascade command 885 HC (see figures 13-7 and 13-8).

A maximum of 8 appliances can be cascaded (examples with 4 are shown in figures 13-7 and 13-8).

Follow the 885 HC command manual for the instructions on how to cascade appliances.

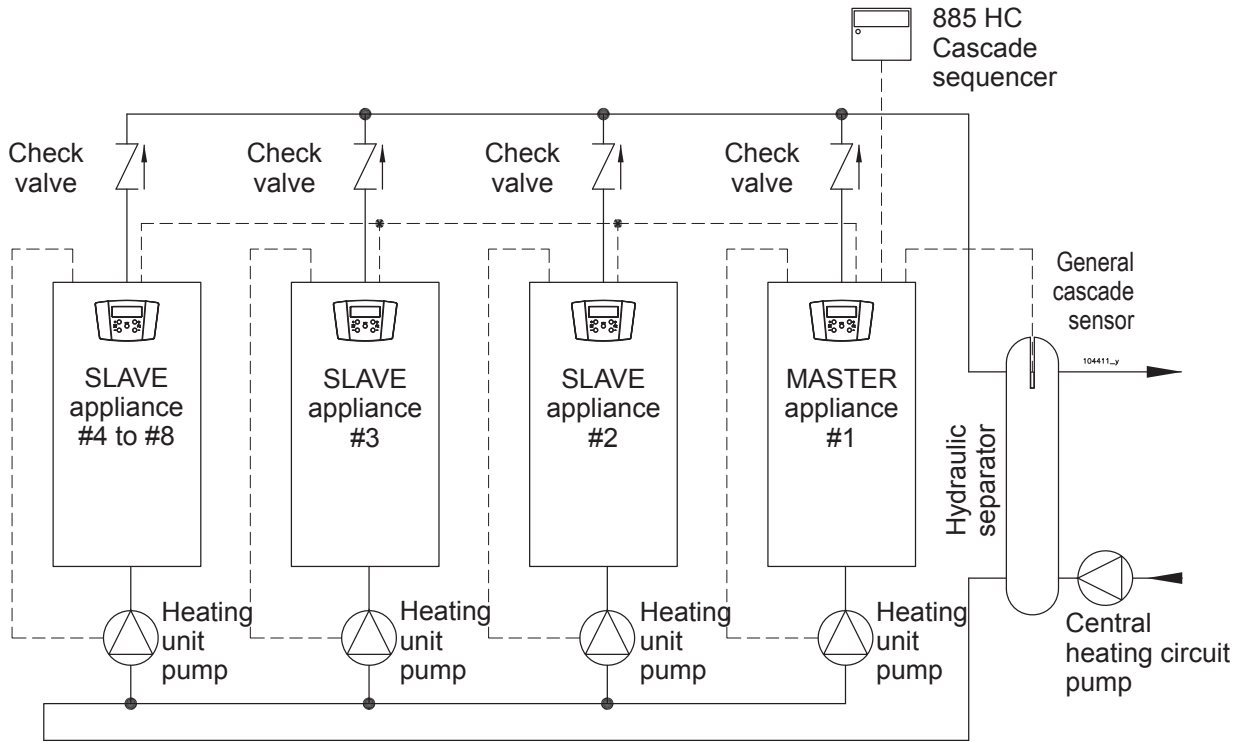

Figure 13-7 – Concept diagram: cascading MYDENS appliances

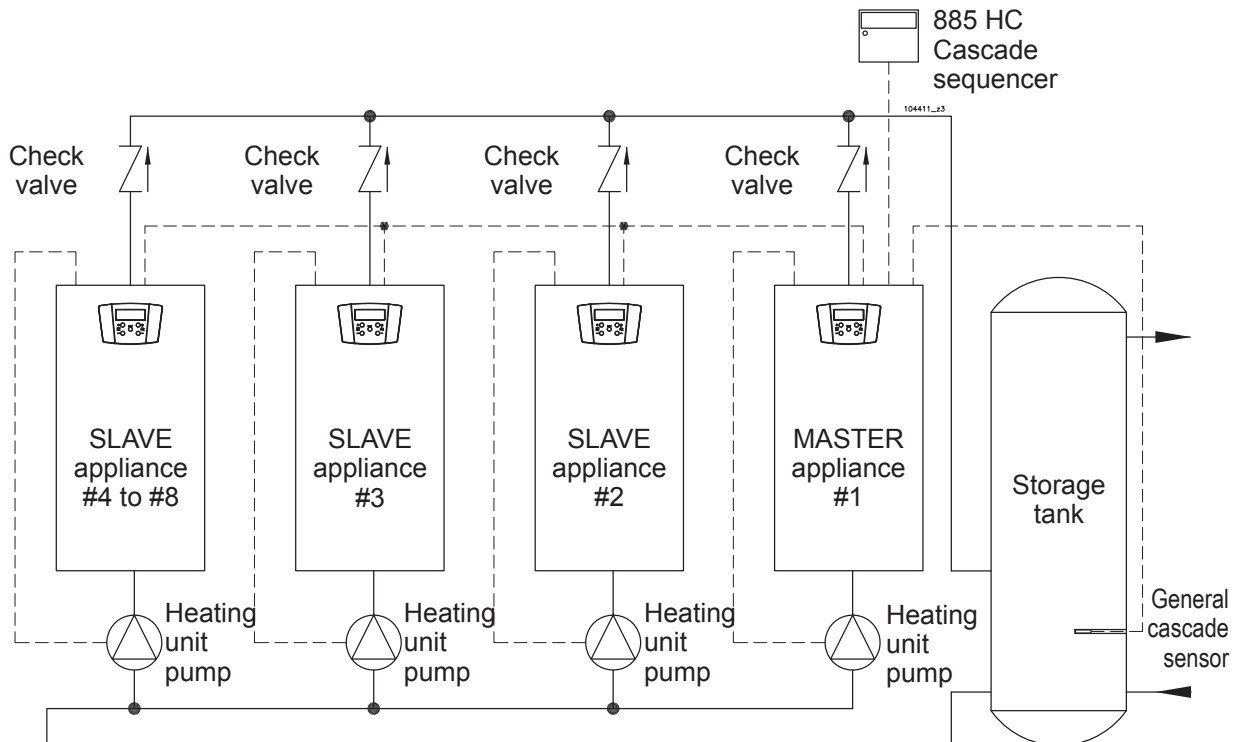





Figure 13-8 – Concept diagram: cascading AGUADENS appliances

14 - INSTALLATION - Flue gas outlet and air intake pipe

14.1 - Burned gas exhaust and combustion agent air intake pipe

 **WARNING!** This boiler must be connected to a flue gas outlet system capable of taking the flue gases to the open air, outside the building.

 **WARNING!** To connect the burned gas exhaust and combustion agent air intake, the relevant national and local regulations must be respected.

 **WARNING!** The flue gases emitted by this boiler can reach 90°C in some circumstances. Therefore plastic flue gas outlet ducts capable of resisting this temperature must be used.

 **WARNING!** This appliance is a “condensing” boiler. Use AISI 316L stainless steel materials or polypropylene plastic materials to make the flue gas exhaust so as to prevent corrosion due to the acidity of the condensate.

Please remember that appliances of this type must have exhaust and intake pipes supplied by the manufacturer of the appliance itself. Other types of pipes, if used, must be type-approved for this intended use. The types of outlet for which the appliance is approved are given in the technical features table at the end of the manual under the heading

“type” and on the data plate on the boiler, also under the heading “type”.

The symbols used to define the type of exhaust are given below:

- B23 and B23P, intake in room and flue gas outlet through wall or roof.

 **WARNING!** The boiler is to be installed with outlet type B23 or B23P and will therefore take in air for combustion from the room in which it is located. Therefore, all precautions must be taken regarding ventilation of the rooms as prescribed by the national and/or local regulations.

During operation, especially in winter, because of the high efficiency, it is possible that white smoke could emerge from the boiler’s flue gas outlet. This is a natural phenomenon and is not a cause for concern. It is the water vapour in the flue gas which condenses when it comes into contact with the outside air.

14.1.1 - Type of intake/exhaust B23 and B23P

In the case of B23 and B23P type combustion agent air intake/flue gas exhaust systems, it is essential that the rooms in which the appliances are installed have at least as much air as is required for combustion and ventilation of the room. It is therefore opportune to remember that the combustion of 1m³ of gas requires 11m³ of air.

The natural flow of air must occur directly through permanent openings made in the walls of the room to be ventilated, which connect to the outside and are far away from sources of pollution such as: vent pipes of dubious origin, industrial air outlets, etc. (see section 5.1.1).

The ventilation openings must meet the following requirements:

- ☞ have clear passage sections of at least 0.3 m²;
- ☞ be made in such a way that the opening ports both inside and outside the wall cannot be obstructed;
- ☞ be protected, for example with grills, metallic mesh, etc. The net passage cross-section must not be reduced by these systems;
- ☞ be situated approximately at floor level and so as not to cause any problems with the operation of the combustion product exhaust devices; where this position is not possible, increase the section of the ventilation openings by at least 50%.

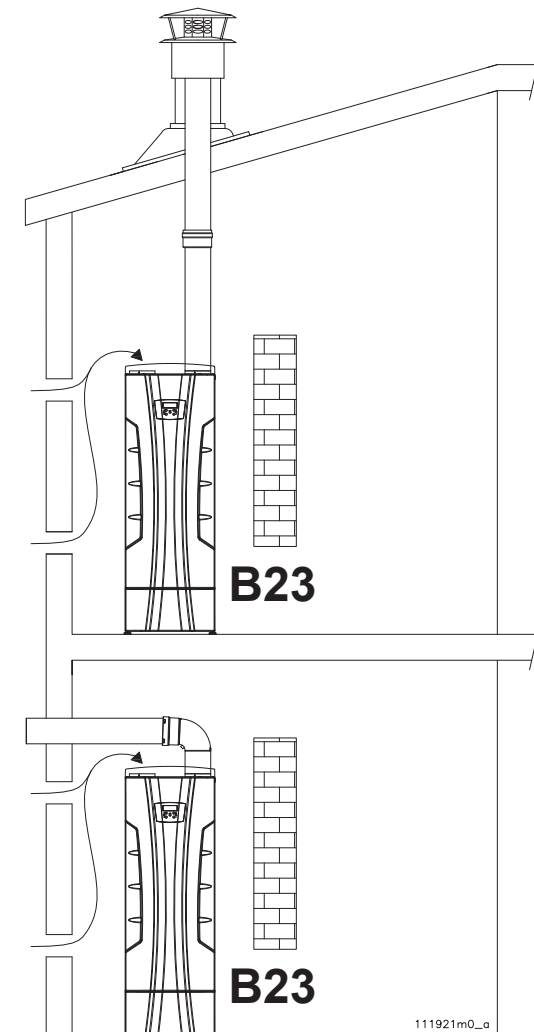

Figure 14-1 – Exhaust/intake systems

14 - INSTALLATION - Flue gas outlet and air intake pipe

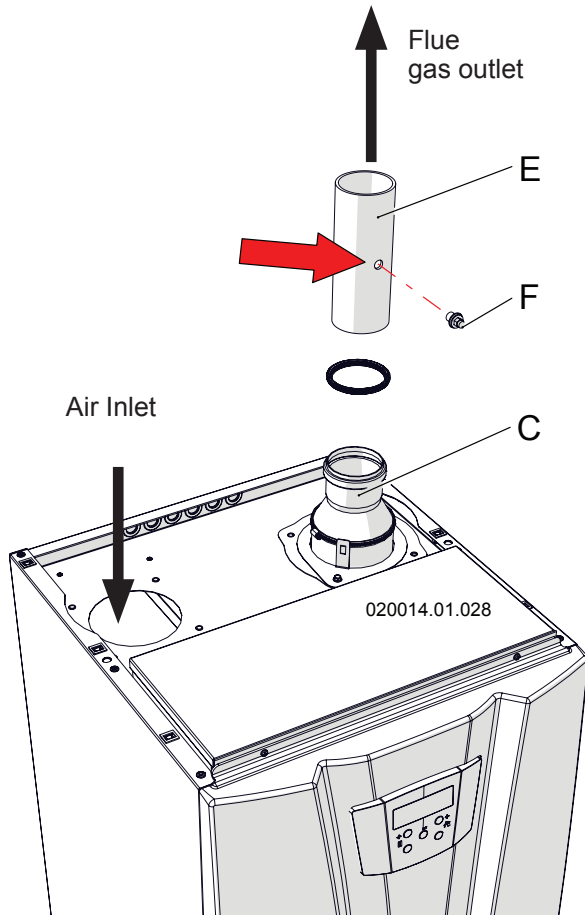

Figure 14-2 – Installing the split system

14.1.2 - Split system

The boiler is supplied as standard with the joint to connect the flue gas outlet. For installation proceed as shown in figure 14-2.

1.- insert pipe "E" into reducer "C" taking care that the gasket provided is in the correct position;

☞ Polypropylene pipes, more resistant to the formation of condensate, must be installed.

☞ Take particular care with the installation of pipes in the part that goes through the wall to the outside. Normal maintenance operations must always be possible; therefore, install the pipes in a sheath so that they can be slid out.

☞ The horizontal sections must always have a slope of at least 2% towards condensate outlet devices.

☞ The boiler is already provided with a condensate collector that must be connected to an outlet pipe (see section 12).



WARNING! This condensate outlet is designed to drain away all of the liquid produced by a single appliance. If more than one boiler is installed, each boiler should be provided with its own condensate outlet.

The flue gas exhaust/air intake system can be extended up to a maximum distance as indicated in section 19. Each 90° bend has a loss equivalent to that reported in section 19.



WARNING! The flue gas outlet terminal must be correctly protected against the effects of the wind.



WARNING! Mechanically secure the joints between the various component elements of the exhaust and intake pipe, through the use of fixing systems or equivalent systems. See figure 14-4.



WARNING! The temperature of the exhaust pipe can reach 90°C during operation. If the pipe passes through walls that are sensitive to these temperatures, insert a protective heat-insulating sheath.



WARNING! The outlet duct must be suitably supported by rigid rods positioned not more than 1 m from each other. The rods must be fastened to rigid walls that can take the weight of the duct itself.

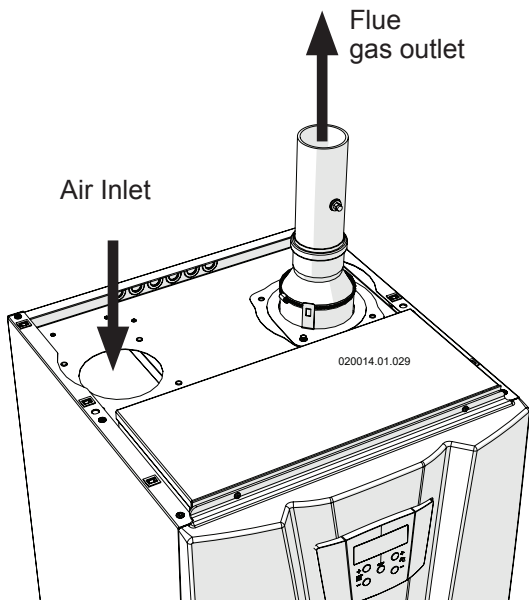

Figure 14-3 - Assembled system

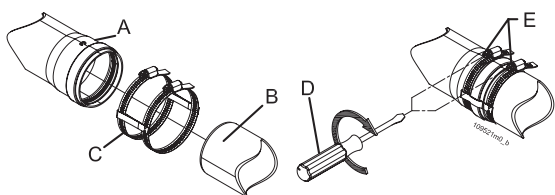

Figure 14-4 – Fixing the exhaust and intake pipes

15 - INSTALLATION - External cover

15.1 - Installation of external cover for models 70T - 140T



WARNING:

the small parts of this kit will have the following references:

- Screw 6x20 will be shown by "A";
- Screw 4x10 will be shown by "B";
- Screw 4x25 will be shown by "C";
- Screw 4x20 will be shown by "D".



WARNING:

Overtightening of screws "C" may lead to deformation of the panel on which they are applied.

For installation of the external cover, proceed as follows:

- 1.- Loosen, with the relevant spanner, the boiler's adjustable feet "T" (figure 15-1), insert rod "H" and retighten the adjustable feet "T" (figures 15-2 and 15-3). Repeat the same procedure on the opposite side.
- 2.- Remove the boiler's upper and lower front covers "F" and the top cover "U", as shown in figure 15-4.
- 3.- Insert the lower framework "J" (figure 15-5) and attach it to rod "H" with the relative screws "A" in correspondence with the holes that are present (figure 15-6).
- 4.- Replace the boiler's upper and lower front covers "F" (figure 15-7). Then adjust the adjustable feet "I" of the lower framework "J" to regulate the boiler's stability on the surface it is installed on (figure 15-8).
- 5.- Insert the four tubes "K" in correspondence with the pins present on the lower framework "J" using a rubber mallet (figures 15-9 and 15-10).
- 6.- Insert the upper framework "G" of the external cover using a rubber mallet (figure 15-11).
- 7.- Insert the upper fixing rods "Q" (figures 15-12 and 15-13). Then put in screw "A" with nut "E" for fastening the rods to the boiler (figure 15-14) and screw "B" for fastening the rods to the framework of the external cover (figure 15-15).
- 8.- Attach the cover (AB), using screws "C", to the framework of the external cover, as shown in figure 15-16.
- 9.- Put on the covers (AA) and (AC) in the direction shown in figure 15-19 and fasten them to the structure with screws "C"; first removing the pre-cut discs present (figures 15-17 and 15-18). It is also possible, depending on the type of electrical and condensate removal system in the place the boiler is installed, to remove if necessary the pre-cut sections "X" and "Y" on the metal sheet (AC) shown in figure 15-19.
- 10.- Fix the two anti-rain grills "R" and the metal plates "S" to the covers previously assembled; using screws "B" (figure 15-20).
- 11.- Fix the metal plates "V", with screws "B", onto the back of the external cover, as shown in figure 15-21.
- 12.- Put on the side covers (AD), attaching them to the structure with screws "C" (figure 15-22).
- 13.- Position the top cover (AE) as shown in figure 15-23 and fix it to the upper framework "G" using screws "B" (figure 15-24), in correspondence with the holes present.
- 14.- Attach, using screws "D", the shelter for the electrical connections "L", for the intake "M" and for the outlet "N" (or "P") to the top cover (figures 15-25 and 15-26); remembering to insert gaskets "O" and "W" as shown in figure 15-25.



WARNING:

- If you have a flue gas outlet 110 mm in diameter, use outlet cover "N" in figure 15-25.
 - If you have a flue gas outlet 80 mm in diameter, use outlet cover "P" in figure 15-25.
- 15.- Put on the front cover (AN) as shown in figure 15-27 and 15-28. Attach it to the structure by tightening locks "Z" with a flat-head screwdriver (figure 15-29).
 - 16.- Finally, attach metal sheets (AR) and (AS), using screws "B", to the lower framework "J"; as shown in figures 15-30 and 15-31.

15 - INSTALLATION - External cover

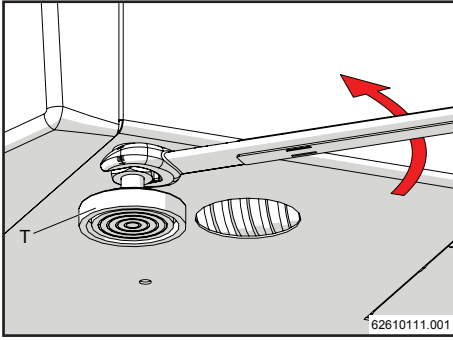

Figure 15-1

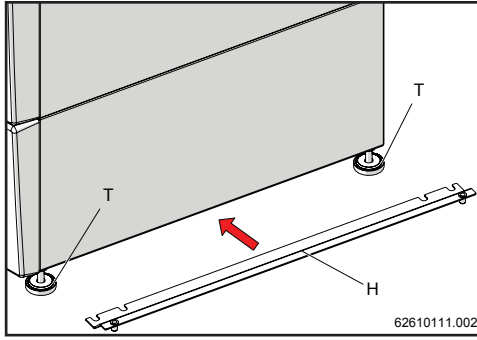

Figure 15-2

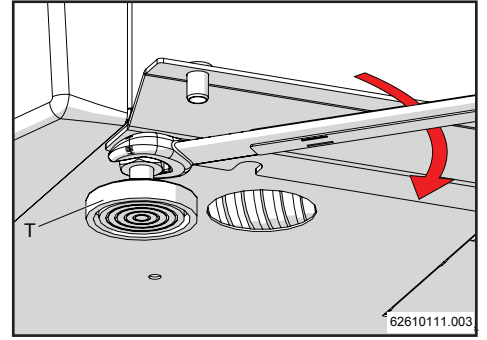

Figure 15-3

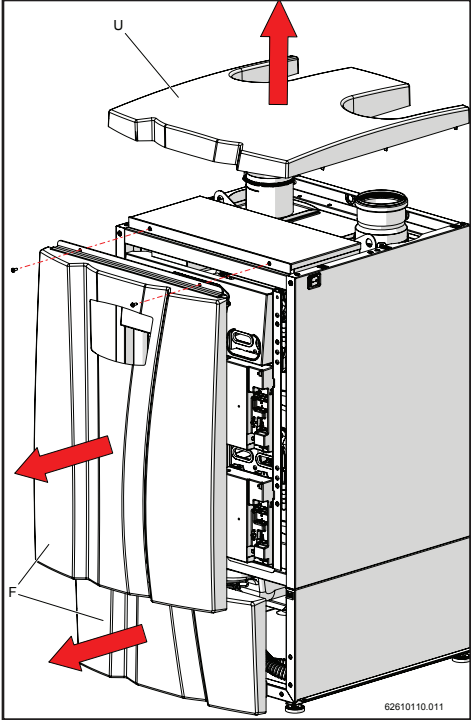

Figure 15-4

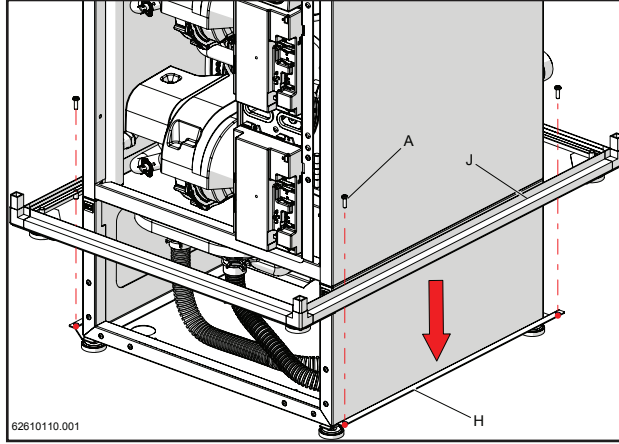

Figure 15-5

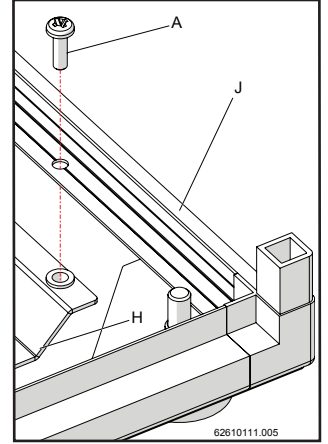

Figure 15-6

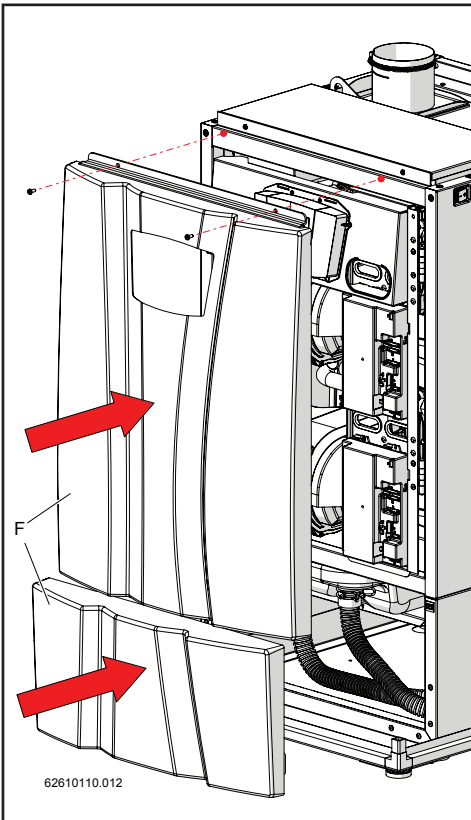

Figure 15-7

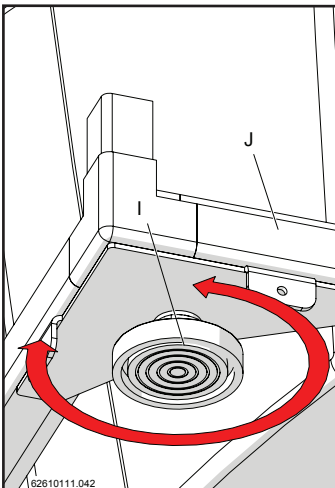

Figure 15-8

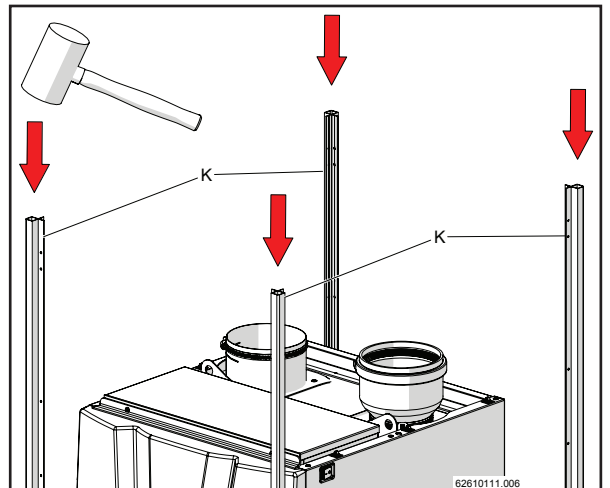

Figure 15-9

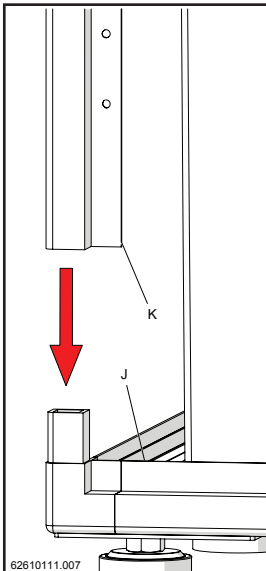

Figure 15-10

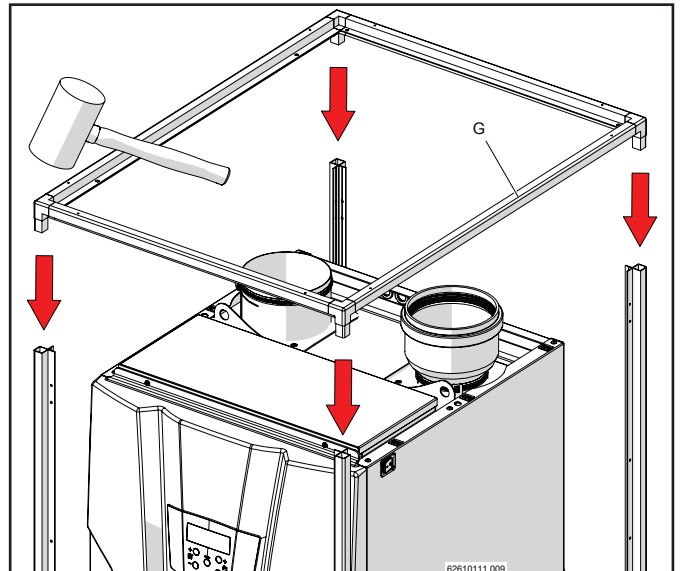

Figure 15-11

15 - INSTALLATION - External cover

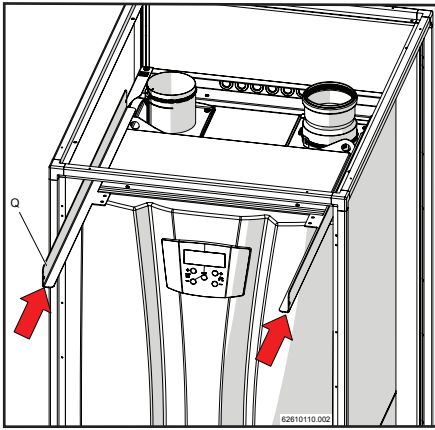

Figure 15-12

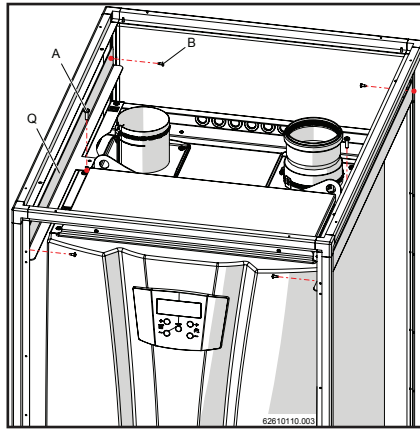

Figure 15-13

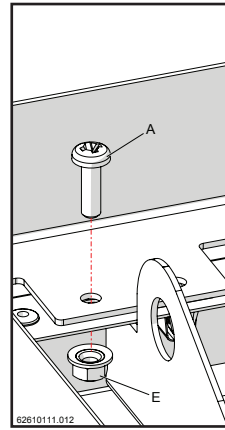

Figure 15-14

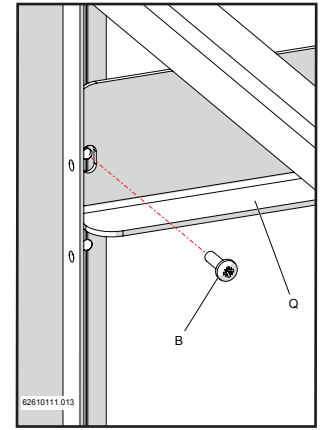

Figure 15-15

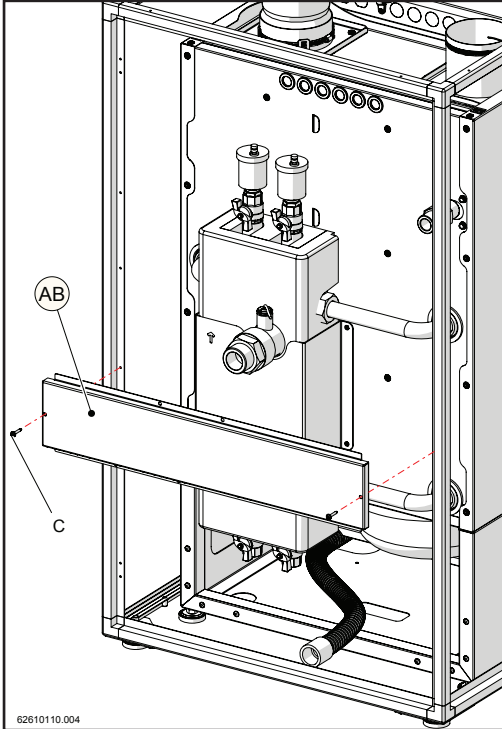

Figure 15-16

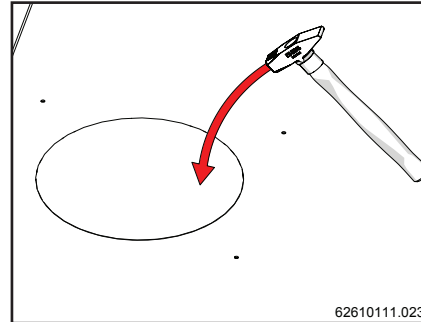

Figure 15-17

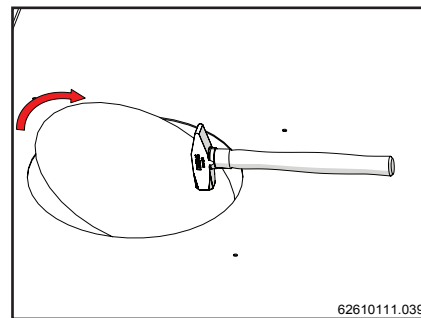

Figure 15-18

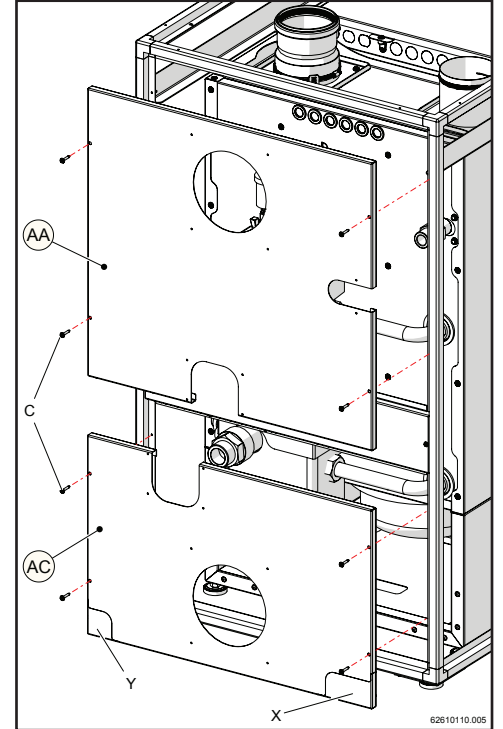

Figure 15-19

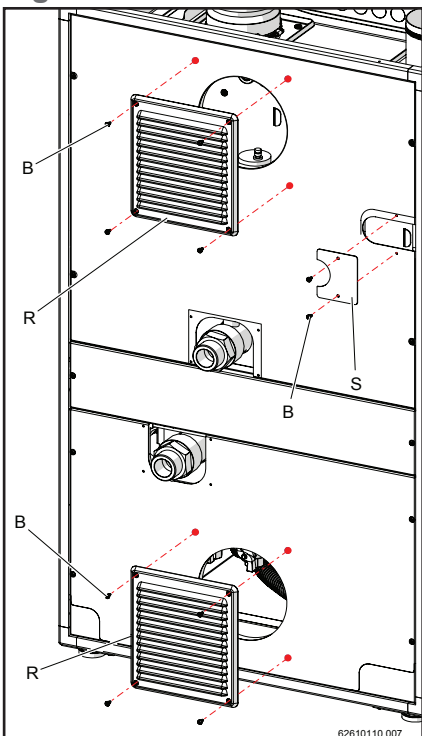

Figure 15-20

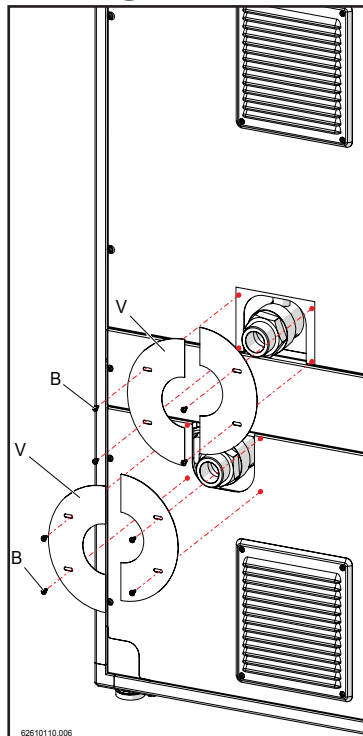

Figure 15-21

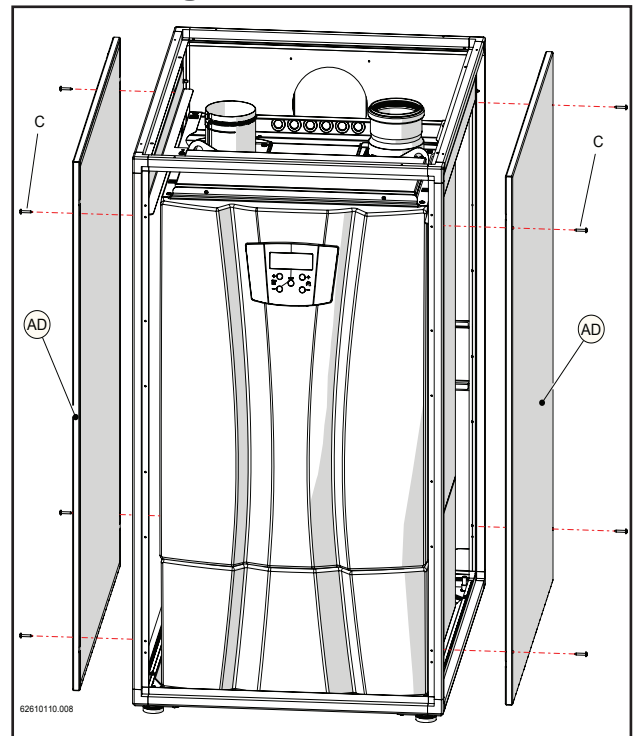

Figure 15-22

15 - INSTALLATION - External cover

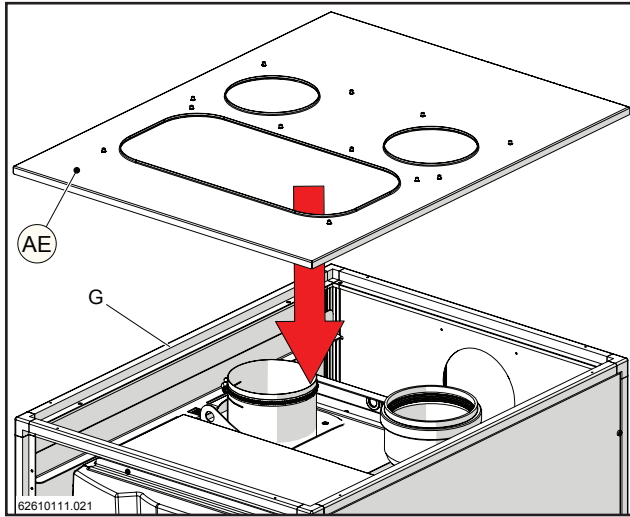

Figure 15-23

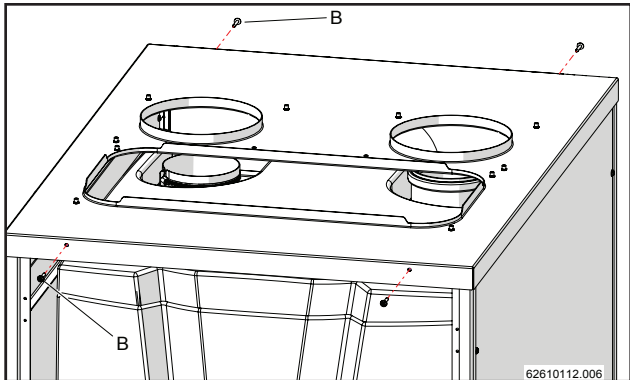

Figure 15-24

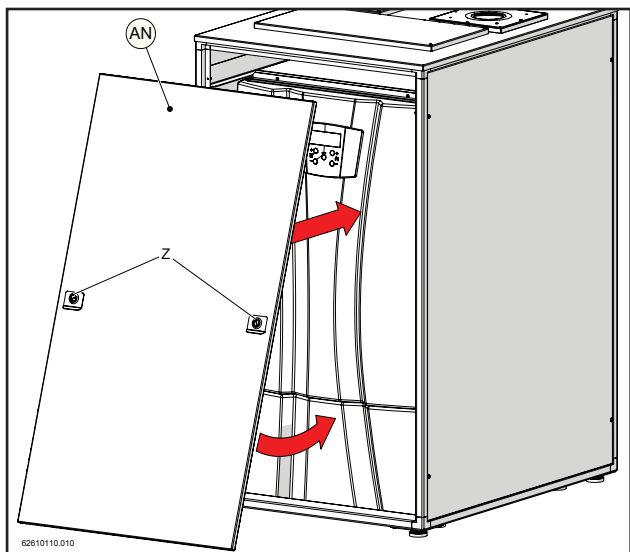

Figure 15-27

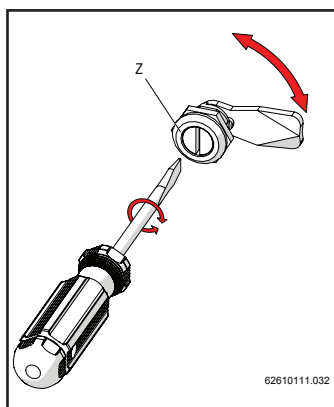

Figure 15-29

COSMOGAS

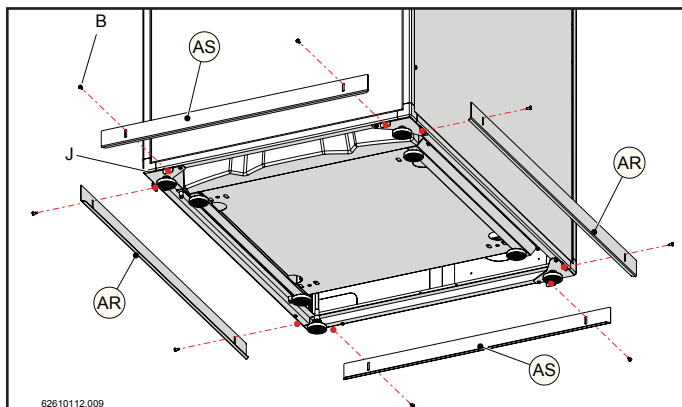

Figure 15-30

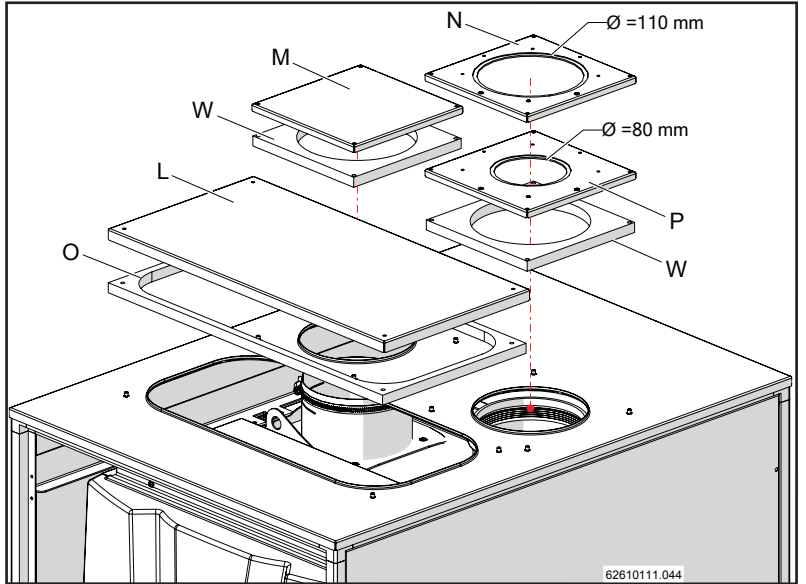

Figure 15-25

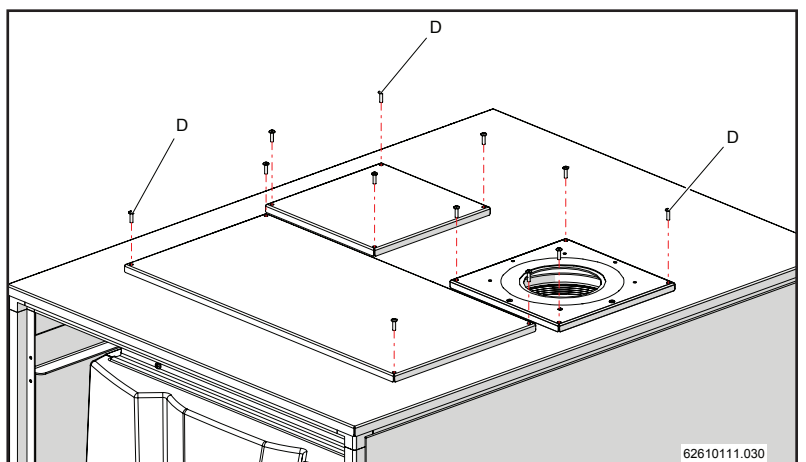

Figure 15-26

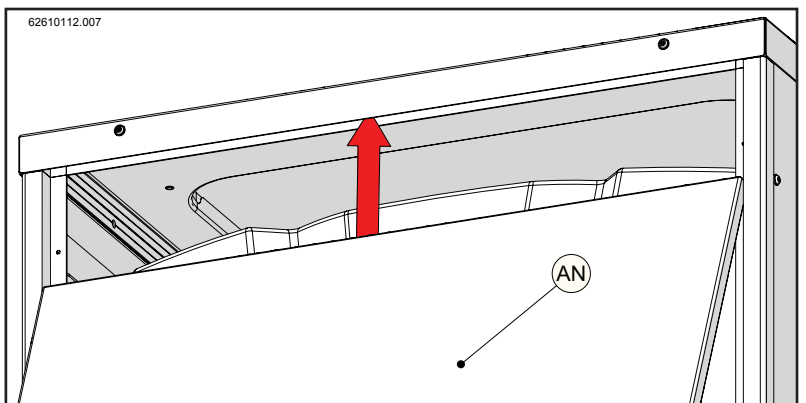

Figure 15-28

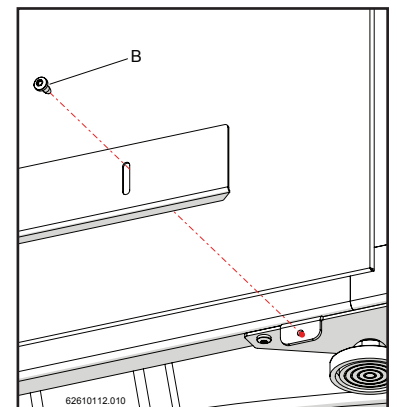

Figure 15-31

15.2 - Installation of external cover for models 210T - 280T

**WARNING:**

The small parts of this kit will have the following references:

- Screw 6x20 will be shown by "A";
- Screw 4x10 will be shown by "B";
- Screw 4x25 will be shown by "C";
- Screw 4x20 will be shown by "D".

**WARNING:**

Overtightening of screws "C" may lead to deformation of the panel on which they are applied.

For installation of the external cover, proceed as follows:

- 1.- Loosen, with the relevant spanner, the boiler's adjustable feet "T" (figure 15-32), insert rod "H" and retighten the adjustable feet "T" (figures 15-33 and 15-34). Repeat the same procedure on the opposite side.
- 2.- Remove the boiler's upper and lower front covers "F" and the top cover "U", as shown in figure 15-35.
- 3.- Insert the lower framework "J" (figure 15-36) and attach it to rod "H" with the relative screws "A" in correspondence with the holes that are present (figure 15-37).
- 4.- Replace the boiler's upper and lower front covers "F" (figure 15-38). Then adjust the adjustable feet "I" of the lower framework "J" to regulate the boiler's stability on the surface it is installed on (figure 15-39).
- 5.- Insert the four tubes "K" in correspondence with the pins present on the lower framework "J" using a rubber mallet (figures 15-40 and 15-41).
- 6.- Insert the upper framework "G" of the external cover using a rubber mallet (figure 15-42).
- 7.- Insert the upper fixing rods "Q" (figures 15-43 and 15-44). Then put in screw "A" with nut "E" for fastening the rods to the boiler (figure 15-45) and screw "B" for fastening the rods to the framework of the external cover (figure 15-46).
- 8.- Insert in the direction shown in figure 15-47, the bolts "V" (not supplied at present in the kit) for plumbing.
- 9.- Position metal sheets (AA) and (AB) (figure 15-50) in the direction shown in figure 15-48. Then attach them to the framework of the external cover with screws "B" (figure 15-49).
- 10.- Insert metal sheets (AC) and (AD) in figure 15-54 respectively in front of (figure 15-51) and behind (figure 15-52) the previously assembled metal sheets in the direction shown by the arrows. Then put in screws "B" as in figure 15-53.



WARNING: the metal sheets (AC) and (AD) include holes of different diameters (see figure 15-54). For correct assembly, position them in the ways described in point 10.

- 11.- Remove the pre-cut discs from covers (AG) and (AH) as shown in figures 15-55 and 15-56 and, depending on the type of electrical and condensate removal system in the place where the boiler is installed, it is possible to remove the pre-cut sections "X" and "Y" on the cover (AG) shown in figure 15-57 if necessary.
- 12.- Put on the covers (AF) and (AG) as shown in figure 15-57 and fasten them to the structure with screws "C" (figure 15-58). Then attach the anti-rain grill "R" to the cover (AG) using screws "B", as shown in figure 15-58.

- 13.- Put on the cover (AH) in the direction shown in figure 15-59 and fasten it to the structure with screws "C" (figure 15-60). Then attach anti-rain grill "R" and metal sheet "S" (removing the pre-cut section, as shown in figure 15-61); attaching both with screws "B" (figure 15-60).

- 14.- Put on the side covers (AM) (first) and (AL) (next), attaching them to the structure with screws "C" (figure 15-62).

- 15.- Position the top cover (AE) on the upper framework "G" and attach it using screws "B" in correspondence with the holes (figures 15-63 and 15-64).

- 16.- Attach the shelter for the electrical connections "L", for the intake "M" and for the outlet "N" (or "P") to the top cover using screws "D" (figures 15-65 and 15-66); remembering to insert gaskets "O" and "W" as shown in figure 15-65.

**WARNING:**

- If you have a flue gas outlet 160 mm in diameter, use outlet cover "N" in figure 15-65.
- If you have a flue gas outlet 110 mm in diameter, use outlet cover "P" in figure 15-65.

- 17.- Put on the front covers (AP) (first) and (AN) (next) as shown in figure 15-67 and 15-68. Attach them to the structure by tightening locks "Z" with a flat-head screwdriver (figure 15-69).

- 18.- Finally, attach metal sheets (AR) and (AS), using screws "B", to the lower framework "J"; as shown in figures 15-70 and 15-71.

15 - INSTALLATION - External cover

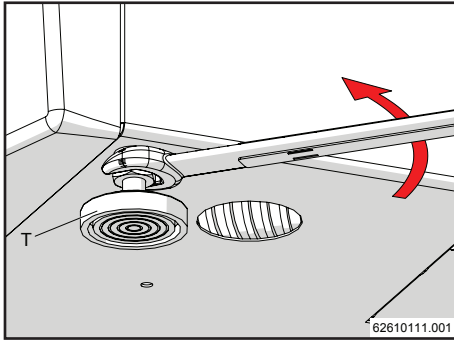

Figure 15-32

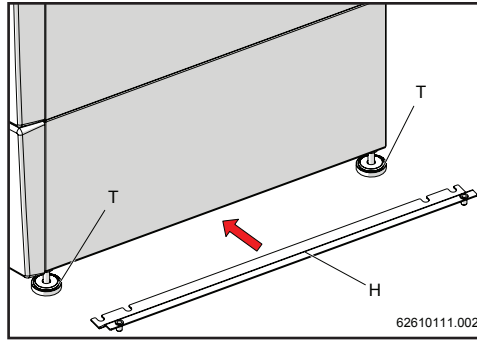

Figure 15-33

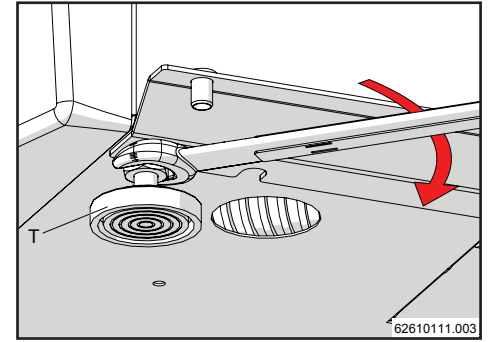

Figure 15-34

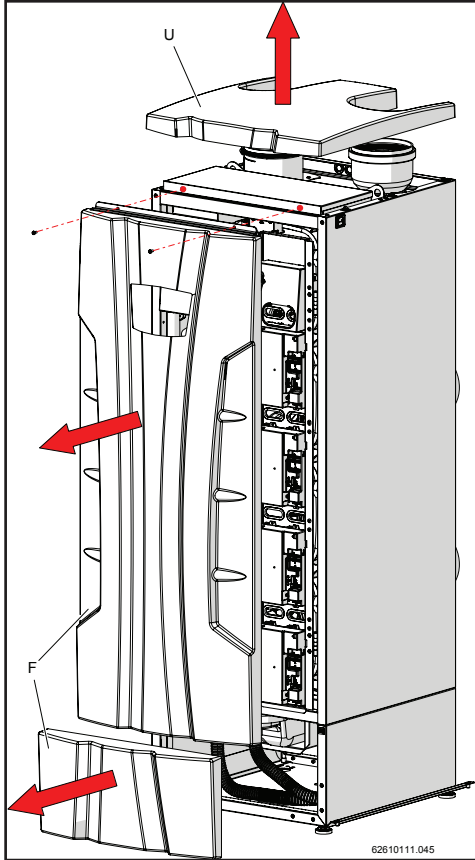

Figure 15-35

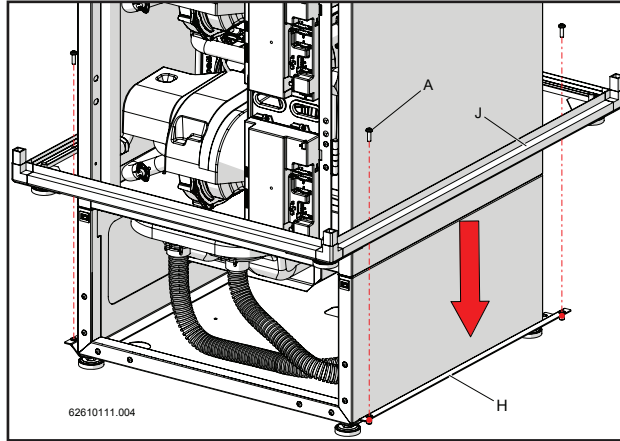

Figure 15-36

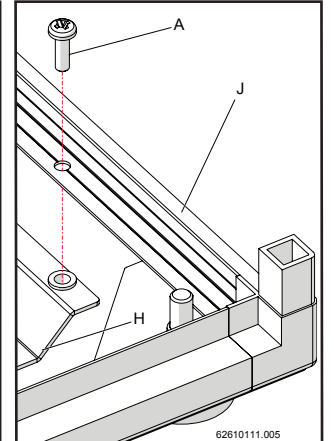

Figure 15-37

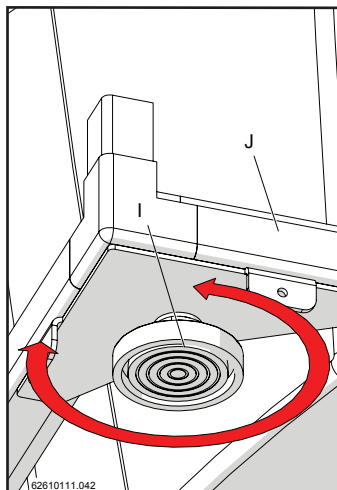

Figure 15-39

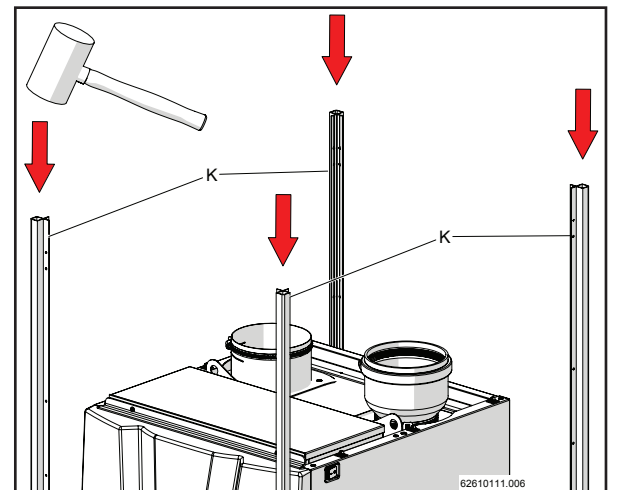

Figure 15-40

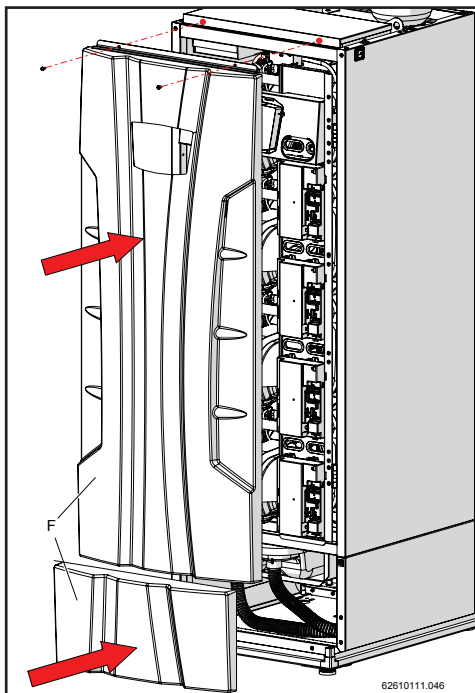

Figure 15-38

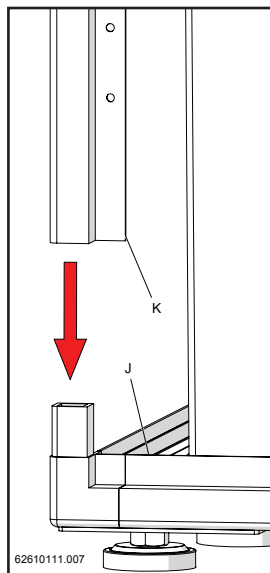

Figure 15-41

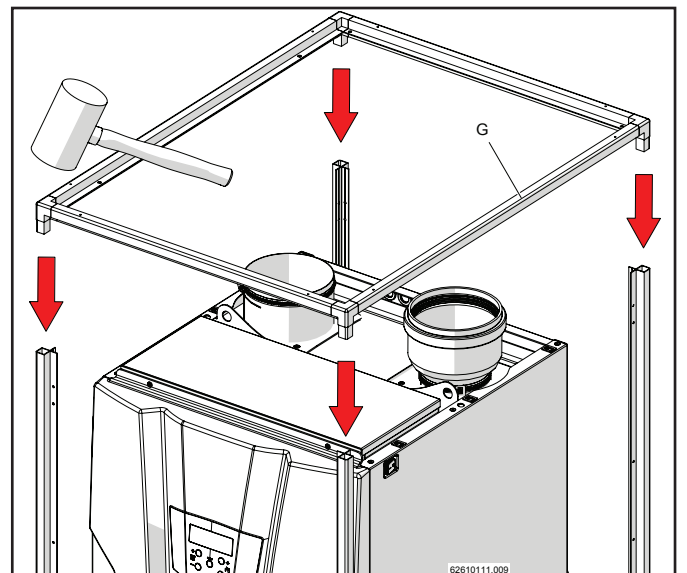

Figure 15-42

15 - INSTALLATION - External cover

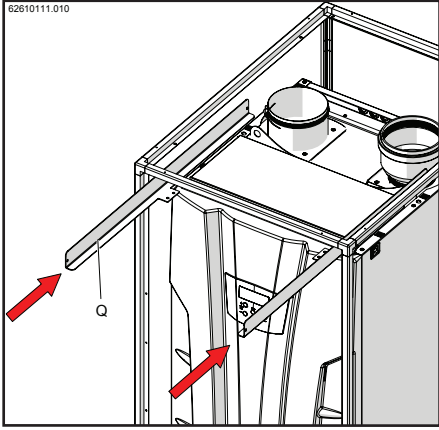

Figure 15-43

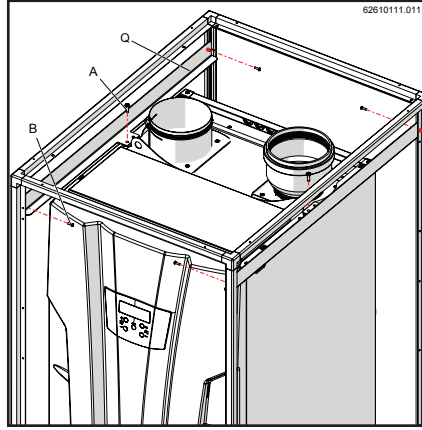

Figure 15-44

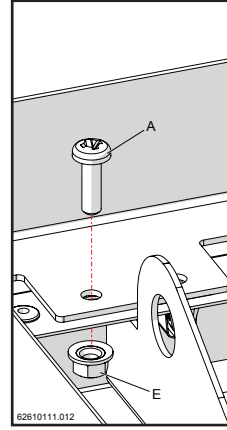

Figure 15-45

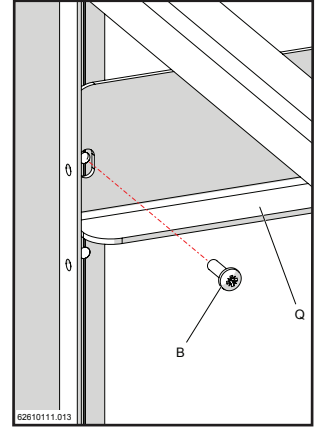

Figure 15-46

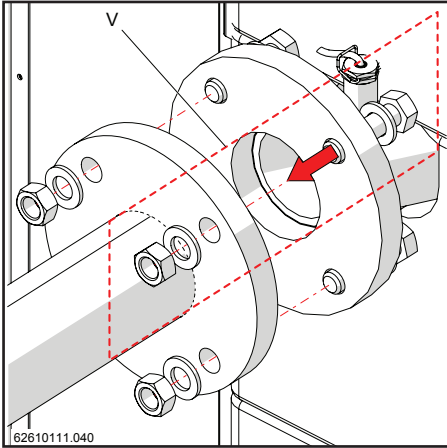

Figure 15-47

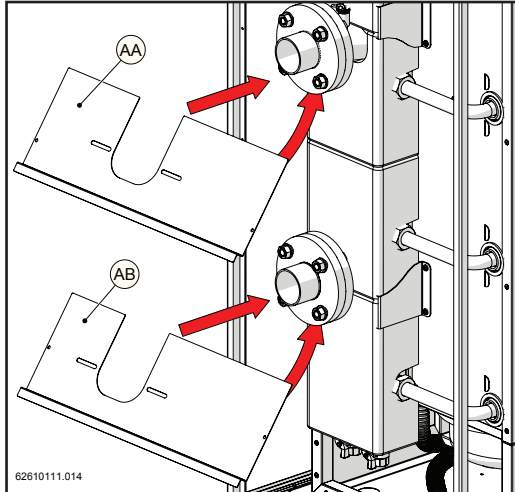

Figure 15-48

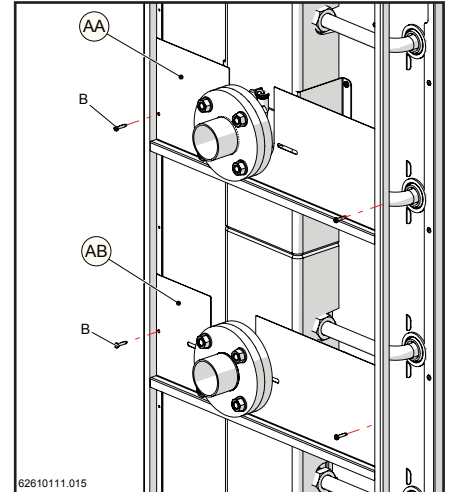

Figure 15-49

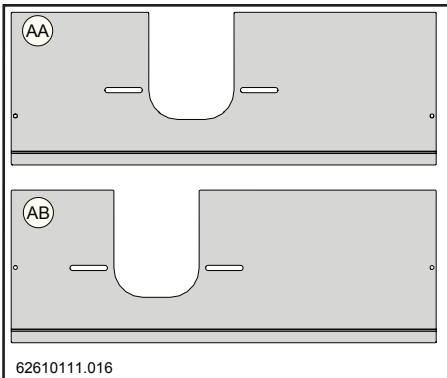

Figure 15-50

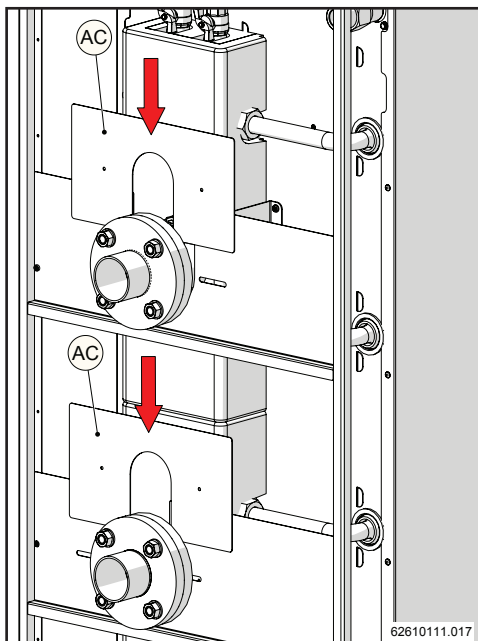

Figure 15-51

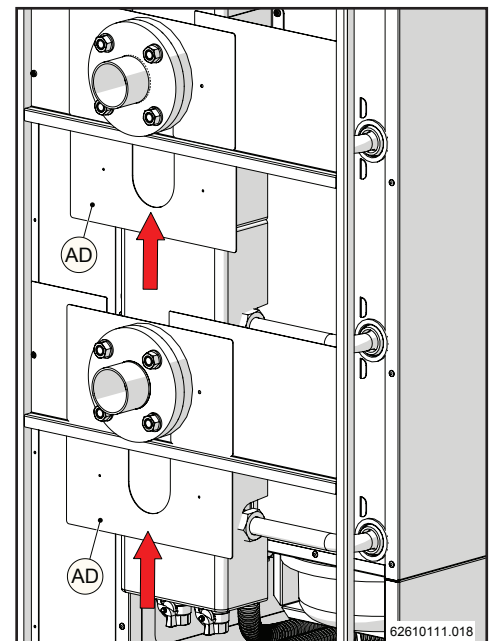

Figure 15-52

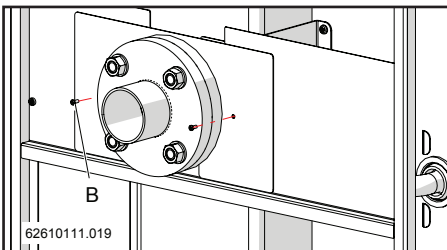

Figure 15-53

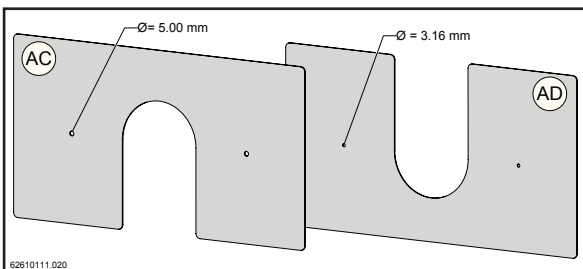

Figure 15-54

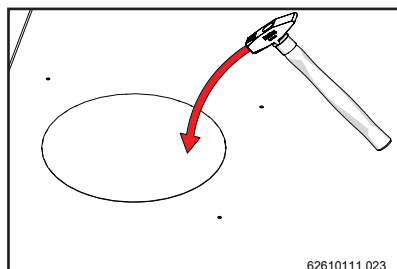

Figure 15-55

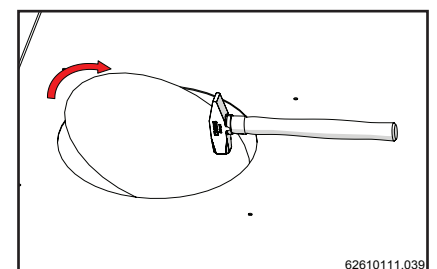

Figure 15-56

15 - INSTALLATION - External cover

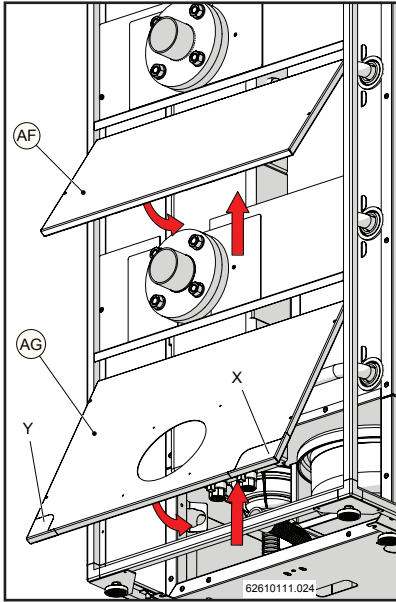

Figure 15-57

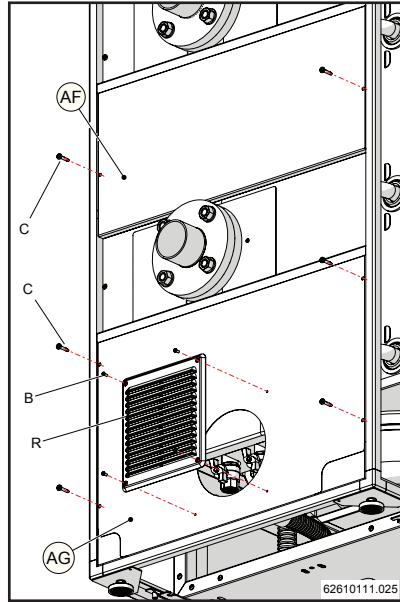

Figure 15-58

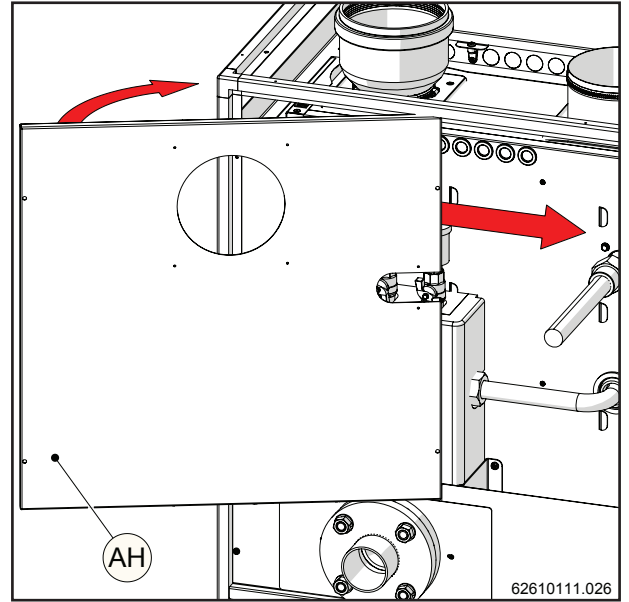

Figure 15-59

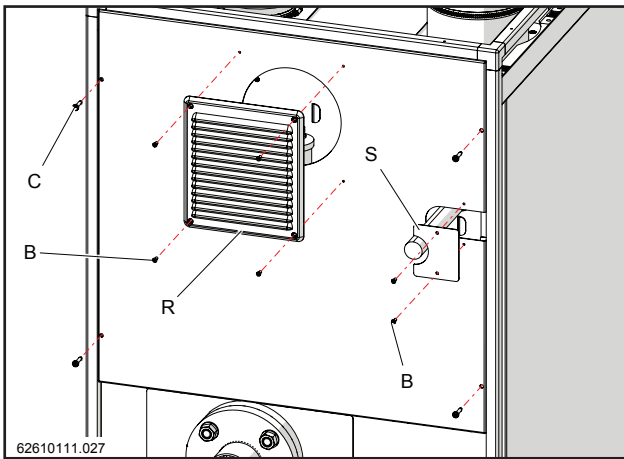

Figure 15-60

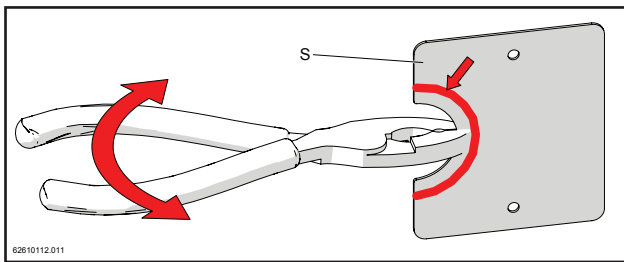

Figure 15-61

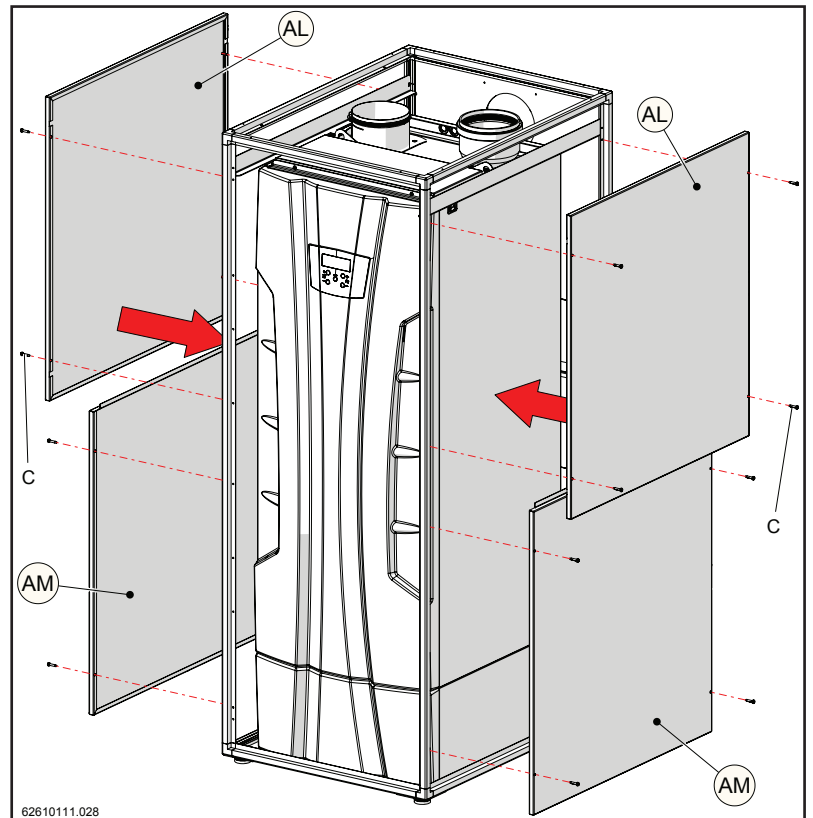

Figure 15-62

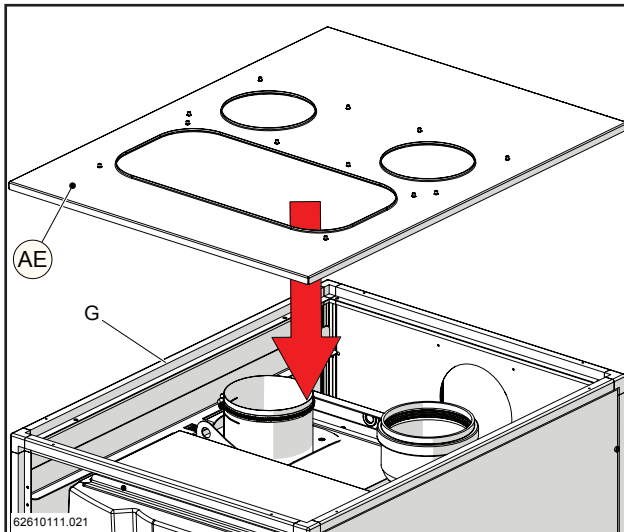

Figure 15-63

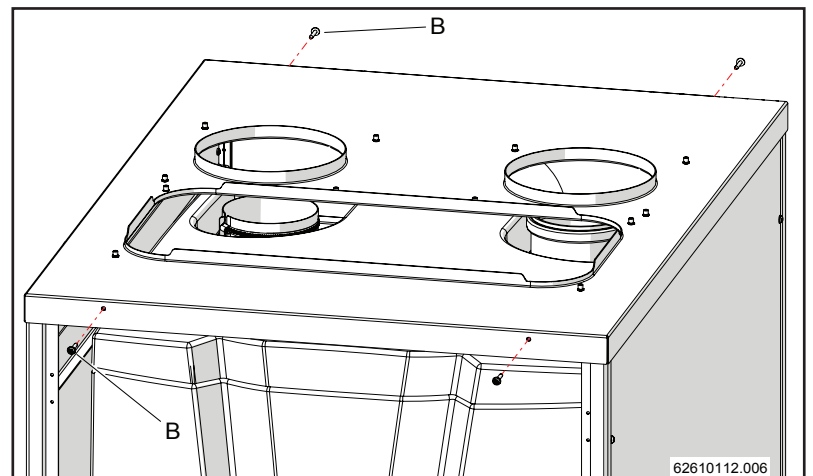

Figure 15-64

15 - INSTALLATION - External cover

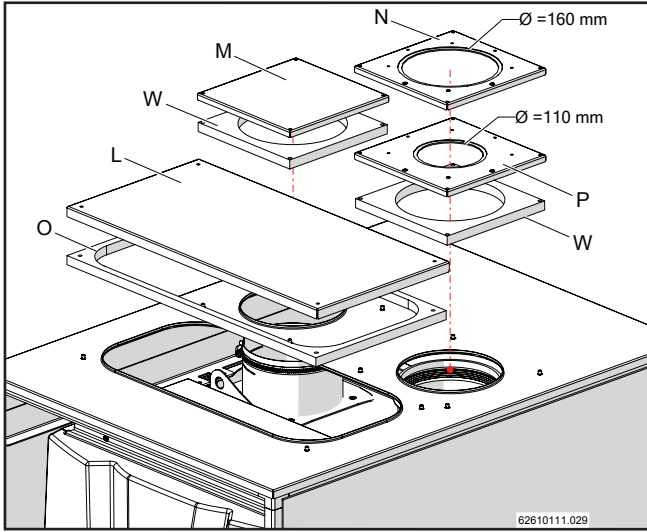

Figure 15-65

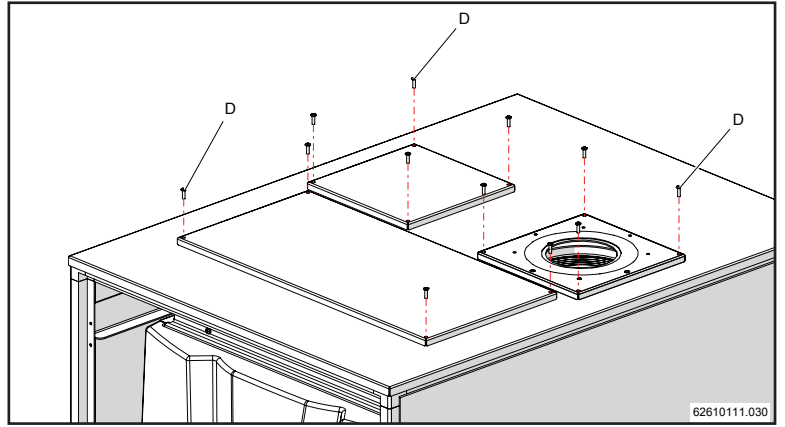

Figure 15-66

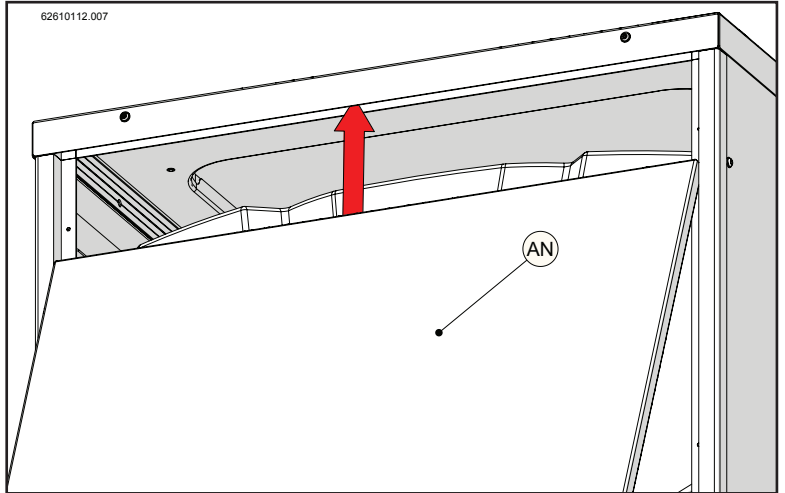

Figure 15-68

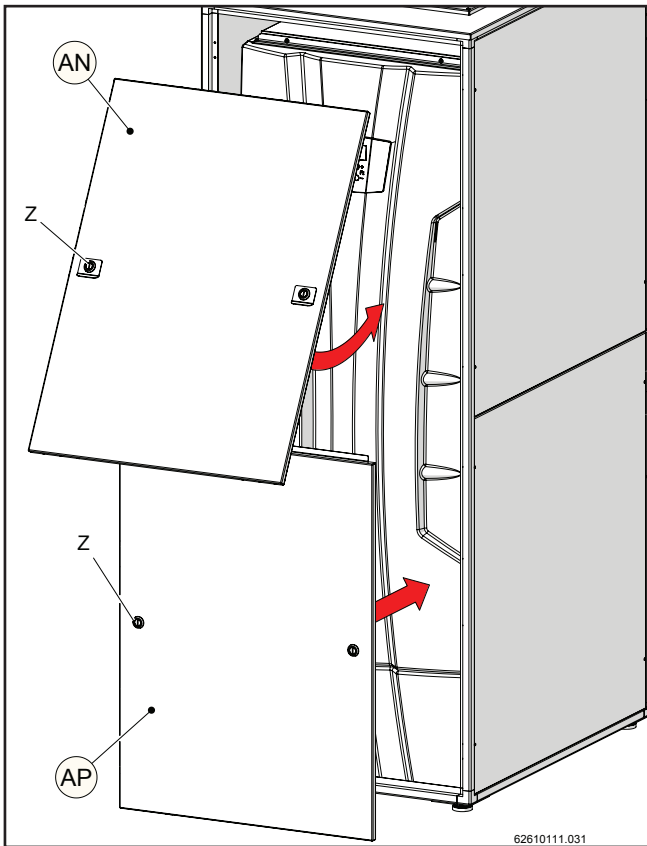

Figure 15-67

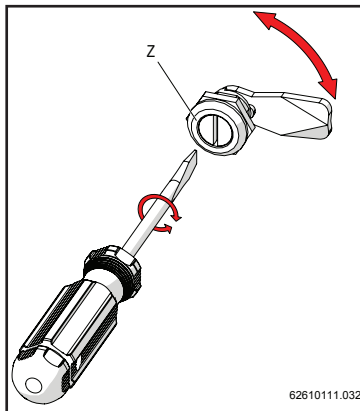

Figure 15-69

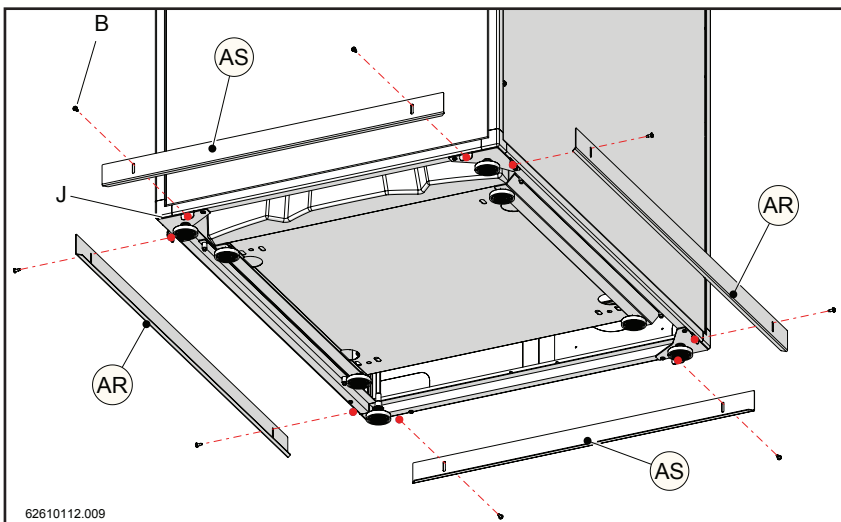

Figure 15-70

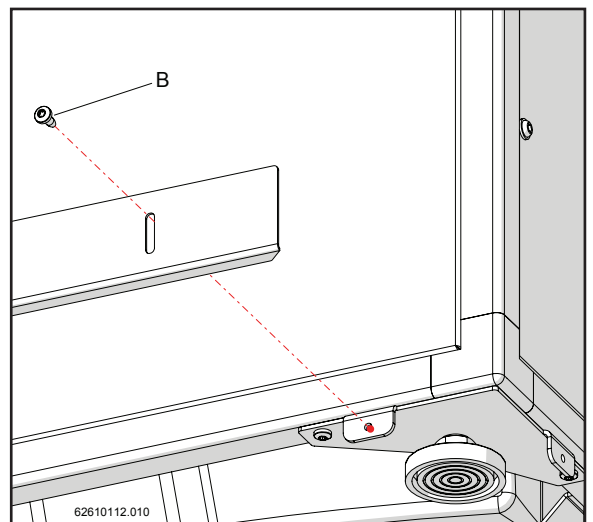

Figure 15-71

16 - START-UP

16.1 - Start-up

Before starting up the boiler, the following operations must be carried out.

16.1.1 - Instructions to the user

Instruct the user on correct use of the boiler and the whole system in general. In particular:

- ☞ Hand over the installation and use manual and all the documentation contained in the package to the user.
- ☞ Instruct the user on any special measures for discharging burned gases, informing them that they must not be modified.
- ☞ Inform the user of the water pressure check that needs to be done on the system and the steps required to fill it and vent the air.
- ☞ Inform the user regarding the correct temperature, control unit/room thermostat and radiator settings for saving energy.

16.1.2 - Filling the condensate outlet siphon

The siphon found inside the boiler must be filled with water to create the shutter that can prevent flue gases from escaping from pipe "5" in figures 3-3, 3-5 and 3-7.

Proceed as follows to do this:

(refer to figure 16-1)

- 1.- undo and remove stopper "A" shown in the figure;
- 2.- insert a rubber tube into hole "S" and at the other end of the tube position a funnel;
- 3.- slowly pour about 5 litres of water through the funnel;
- 4.- reassemble everything in reverse order.

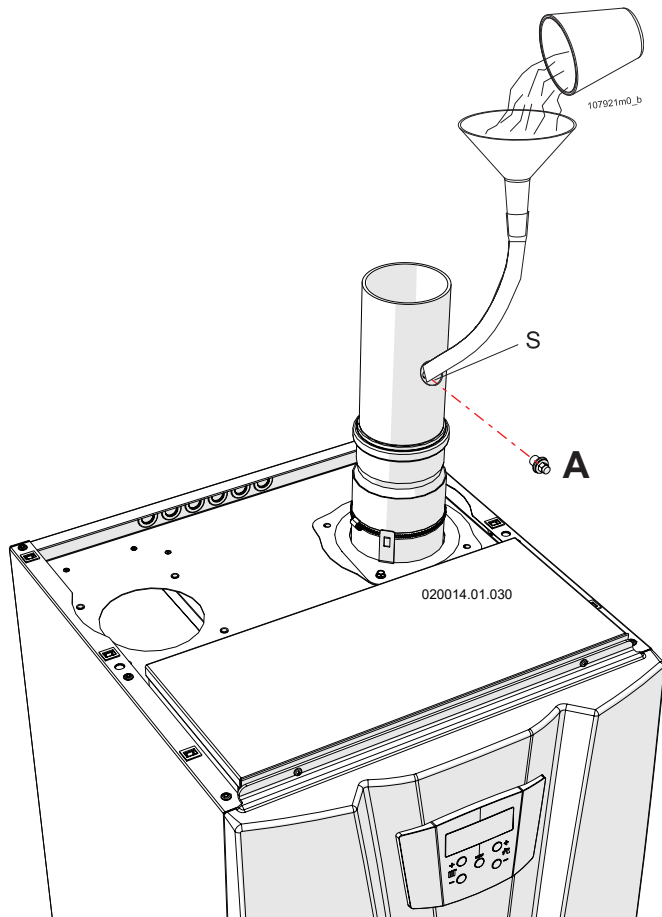

Figure 16-1 – Filling the condensate outlet siphon



WARNING! If the boiler remains off for more than 3 months, the siphon must be filled again as explained above.



WARNING! Once the boiler is back on, check that no exhaust gases are escaping from stopper "A".

16.1.3 - Filling the central heating system

If the message **Err 59** appears on the display when the boiler is powered electrically, this means that the system must be filled. Proceed as follows:

- ☞ only use clean water from the mains.



WARNING! The addition of chemical substances such as anti-freeze must be performed in compliance with the product instructions. In all cases, these substances must not be introduced directly inside the boiler.



WARNING! in the case of the AGUADENS range of hot water heaters the addition of chemical substances such as antifreeze is strictly forbidden. Failure to observe this rule could cause serious damage to people's health or even death.

- 1.- open the air vent valve (detail "35" in figure 3-3, 3-5, 3-7)
- 2.- open the filling device provided by the installer upstream from the appliance and fill the system until the pressure gauge reads a pressure of 1.5 bar, showing this on the display (detail "M" in figure 17-1) (on the display the message **Err 59** will disappear); if you want to increase the filling pressure level you must set parameter **3022** to the desired value (see section 20);
- 2.- Make sure there are no water leaks from the fittings;
- 3.- Reclose the filling device provided by the installer upstream from the appliance;
- 4.- Bleed the heating elements;
- 5.- Check the pressure on the boiler display again (detail "M" in figure 17-1). If it has dropped, fill up to 1.5 bar again (or up to the value set).

16 - START-UP

16.2 - General recommendations regarding the gas supply

For first start-up of the boiler carry out the following checks:

- ☞ That it is powered by the type of fuel for which it is set up.
- ☞ That the gas supply pressure (with the boiler on and off) falls between the maximum and minimum values shown in the table in section 19.
- ☞ That the gas adduction system has all the safety and checking devices expected by national and local regulations in force.
- ☞ That the flue gas outlet terminal and the combustion agent air intake terminal are free from any obstruction.
- ☞ That the flue gas outlet terminal and the combustion agent air intake terminal are located outside the building.
- ☞ That the condensate outlet is connected.



WARNING! Do not power the appliance with gases other than those specified.



WARNING! Check that the gas and supply pressure are those for which the boiler has been adjusted.

The boiler is provided with the relevant gas conversion kit.

- ☞ Before installation, clean the inside of the gas supply pipe thoroughly;
- ☞ Install a shut-off cock on the gas supply pipe;
- ☞ To prevent damage to the appliance gas control unit, run a leak test at a pressure not exceeding 50 mbar;
- ☞ If the gas system must be inspected at pressures over 50 mbar, turn the cock located immediately before the boiler, to isolate it from the system.

In figures 8-1, 8-2, 9-1 and 9-2 you can check the position of the gas connection. The sections of tubing making up the gas adduction system must always ensure a supply of gas that is sufficient to cover the maximum demand.



WARNING! If you smell gas:

- A - Do not turn on any electrical device, including a telephone, or any item that could cause sparks;**
- B - Immediately open doors and windows to create a draught that can quickly clear the gas from the room;**
- C - From another room, or from a neighbour's property, immediately call a professionally qualified technician or the gas supply company. Call the Fire Service if the former are not available.**

16.3 - Type of gas for which the appliance is set.

On the right side of the boiler there is a label stating the type and supply pressure of the gas for which the boiler is set. The boiler may have one of the following two types of wording:

2H-G20-20mbar NATURAL GAS

This means that the boiler is set to operate with G20 gas (methane) of group H of the second family, at a supply pressure of 20 mbar.

3P-G31-37mbar LPG

This means that the boiler is set to operate with G31 gas (propane, also known as LPG) of group P of the third family, at a supply pressure of 37 mbar.

16 - START-UP

16.4 - Conversion of boiler models 70T from one type of gas to another



WARNING! Read these instructions carefully before making the gas change:

- The installation, calibration or modification of the gas boiler must be carried out by specialised people, in compliance with the law;
- Check and be certain that the type of gas which is powering the appliance is compatible with the adjustment kit in your possession;
- Do not supply the boiler with a type of gas other than those anticipated.

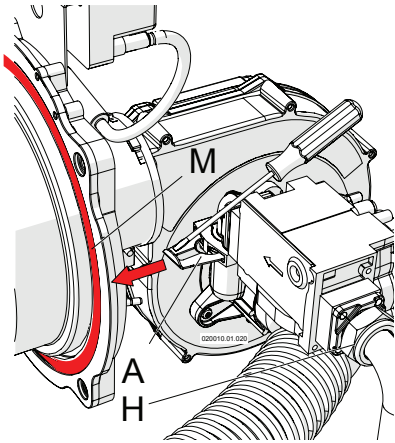

Figure 16-2 – Removing the gas valve

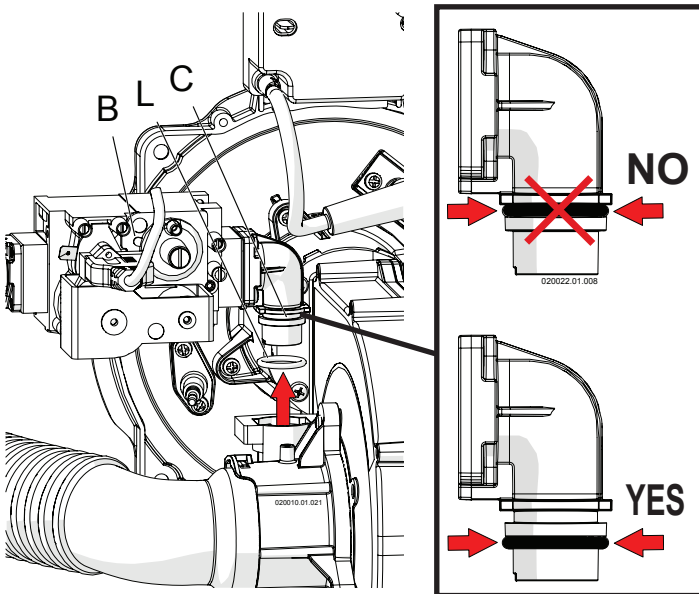

Figure 16-3 - Raising gas valve

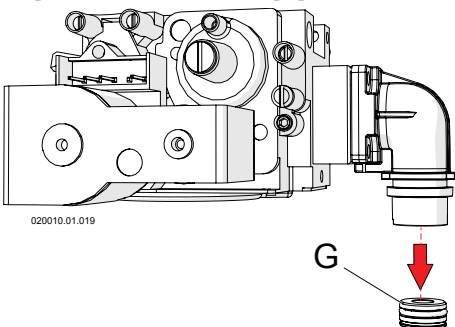

Figure 16-4 – Replacing the gas nozzle

Contents:

The kit (supplied as standard with the boiler) is made up of - label certifying the new type of gas, a gas nozzle for each burner and an instruction sheet;

To carry out the change of gas, proceed as follows:

- 1 - Turn off the boiler by moving the main switch to OFF (detail "T" in figure 17-1);
- 2 - Turn off the gas supply cock;
- 3 - Open the boiler casing as shown in section 18.2;
- 4 - Undo junction "H" in figure 16-2;
- 5 - With the aid of a screwdriver, remove fork "A" in figure 16-2;
- 6 - Remove the gas valve with junction "C" as in figure 16-3 (paying attention to the OR "L" in figure 16-3);
- 7 - Replace nozzle "G" in figure 16-4 with the one in the kit, checking it corresponds in diameter to that shown in table 16-8;
- 8 - Replace the gas valve paying attention to the correct position of the OR "L" in figure 16-3 and to the joint gasket "H" in figure 16-2;
- 9 - Replace fork "A" in the locking housing;
- 10 - Tighten joint "H" in figure 16-2;
- 11 - Open the gas supply valve;
- 12 - Check that there are no leaks from joint "H" in figure 16-2;



WARNING! Test the gas seal using a soap and water solution only. The use of naked flames is prohibited.

- 13 - Turn on the boiler by moving the main switch to ON (detail "T" in figure 17-1);
- 14 - Completely undo screw "E" in figure 16-6 in an anticlockwise direction;
- 15 - Check gas pressure by following section 16.7, the minimum pressure must not be less than 10 mbar while the maximum must not exceed 45 mbar;
- 16 - Check and adjust the CO₂ following the procedure in section 16.8 and checking the value in figure 16-8;



WARNING! The measurements taken must be done with guaranteed calibrated instruments that ensure an accurate reading.

- 17 - Check the boiler's power by following section 16.9;
- 18 - apply the adhesive data plate (see figure 16-7) to the right-hand side of the boiler, in place of the label that identified the old setting status, to certify the boiler's new setting status, as follows: apply label "B" if the boiler has been converted from methane to LPG; apply label "A" if the boiler has been converted from LPG to methane.



WARNING! If you smell gas:

- A - Do not turn on any electrical device, including a telephone, or any item that could cause sparks;
- B - Immediately open doors and windows to create a draught that can quickly clear the gas from the room;
- C - From another room, or from a neighbour's property, immediately call a professionally qualified technician or the gas supply company. Call the Fire Service if the former are not available.

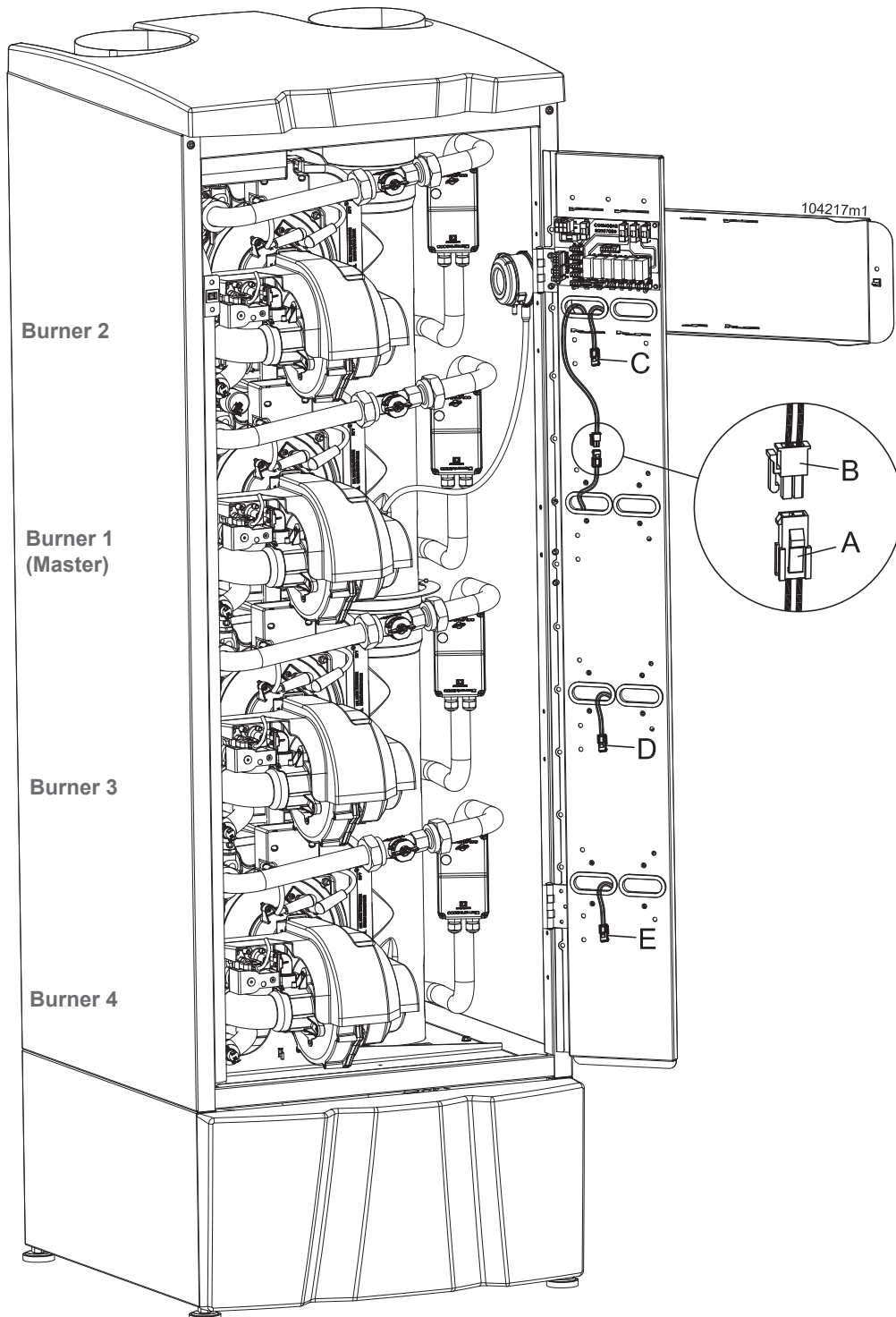

- A - Connector from burner 1 (MASTER)
- B - Connector from display
- C - Connector from burner 2
- D - Connector from burner 3
- E - Connector from burner 4

Figure 16-5 - Burners position

16 - START-UP

16.5 - Conversion of boiler models 140T to 280T from one type of gas to another

Boilers 140T to 280T are multi-burner models, this means that the gas type conversion must be done on each burner.



WARNING! Read these instructions carefully before making the gas change:

- The installation, calibration or modification of the gas boiler must be carried out by specialised people, in compliance with the law;
- Check and be certain that the type of gas which is powering the appliance is compatible with the adjustment kit in your possession;
- Do not supply the boiler with a type of gas other than those anticipated.

Contents:

The kit (supplied as standard with the boiler) is made up of

- label certifying the new type of gas;
- a gas nozzle for each burner;
- an instruction sheet;

To carry out the change of gas, proceed as follows:

- 1 - Carry out the conversion in "Burner 1" (MASTER). See figure 16-5 to identify "Burner 1" (MASTER);
- 2 - Carry out the conversion in "Burner 1" (MASTER) following points 1 to 16 of section 16.4;

After converting "Burner 1", continue with "Burner 2" as shown below:

- 3 - Carry out the conversion in "Burner 2" following points 1 to 16 of section 16.4;

After converting "Burner 2", continue with "Burner 3" (if present) as shown below:

- 4 - Carry out the conversion in "Burner 3" following points 1 to 16 of section 16.4;

After converting "Burner 3", continue with "Burner 4" (if present) as shown below:

- 5 - Carry out the conversion in "Burner 4" following points 1 to 16 of section 16.4;

After converting all the Burners continue as shown below:

- 6 - Check the gas inlet pressure as shown in section 16.7;
- 7 - Check the boiler power as shown in section 16.9;



WARNING! The measurements taken must be done with calibrated instruments that ensure an accurate reading.

- 8.- apply the adhesive data plate (see figure 16-7) to the right-hand side of the boiler, in place of the label that identified the old setting status, to certify the boiler's new setting status, as follows: apply label "B" if the boiler has been converted to G31; apply label "A" if the boiler has been converted to G20.



WARNING! If you smell gas:

- A - Do not turn on any electrical device, including a telephone, or any item that could cause sparks;
- B - Immediately open doors and windows to create a draught that can quickly clear the gas from the room;
- C - From another room, or from a neighbour's property, immediately call a professionally qualified technician or the gas supply company. Call the Fire Service if the former are not available.

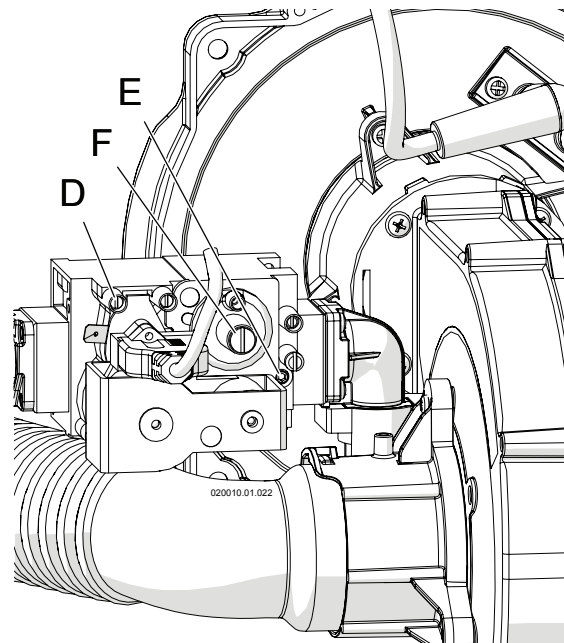

- D - Gas inlet tapping point.
E - CO2 regulation screw.
F - Factory regulation screw (do not touch).

Figure 16-6 – Gas valve

16 - START-UP

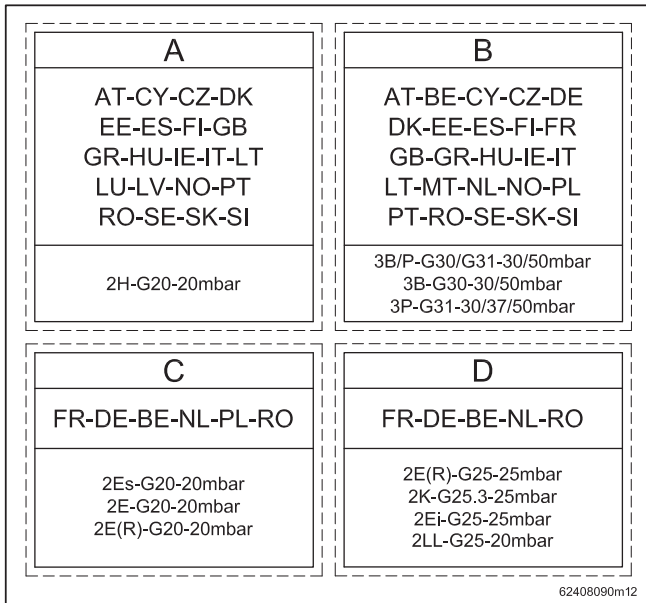





Figure 16-7 – Labels certifying the new boiler status

	U.M.	70T	140T	210T	280T
Rated gas supply pressure G20/G25/G30/G31	mbar	20/25/30/37			
Minimum gas supply pressure G20/G25/G30/G31	mbar	17/20/25/25			
Maximum gas supply pressure G20/G25/G30/G31	mbar	25/30/35/45			
Methane gas nozzle diameter (G20)	mm	9.5	9.5	9.5	9.5
Methane gas nozzle diameter (G25)	mm	N.P.	N.P.	N.P.	N.P.
LPG gas nozzle diameter (G30)	mm	5.7	5.7	5.7	5.7
LPG gas nozzle diameter (G31)	mm	6.4	6.4	6.4	6.4
CO2 Methane gas (G20) at maximum power	%	from 8.4 to 9.0			
CO2 Methane gas (G20) at minimum power	%	from 8.4 to 8.6			
O2 Methane gas (G20) at maximum power	%	from 5.2 to 5.6			
O2 Methane gas (G20) at minimum power	%	from 5.7 to 5.9			
CO2 Methane gas (G25) at maximum power	%	from 8.5 to 9.1			
CO2 Methane gas (G25) at minimum power	%	from 8.3 to 8.5			
O2 Methane gas (G25) at maximum power	%	from 4.7 to 5.1			
O2 Methane gas (G25) at minimum power	%	from 5.5 to 5.7			
CO2 LPG gas (G30) at maximum power	%	from 10.3 to 10.9			
CO2 LPG gas (G30) at minimum power	%	from 9.8 to 10.0			
O2 LPG gas (G30) at maximum power	%	from 4.9 to 5.3			
O2 LPG gas (G30) at minimum power	%	from 6.1 to 6.3			
CO2 LPG gas (G31) at maximum power	%	from 9.9 to 10.5			
CO2 LPG gas (G31) at minimum power	%	from 9.7 to 9.9			
O2 LPG gas (G31) at maximum power	%	from 5.2 to 5.6			
O2 LPG gas (G31) at minimum power	%	from 5.9 to 6.1			



Figure 16-8 - Operating settings for the different gases

16.6 - Ignition

16.6.1 - MYDENS boiler ignition

- 1.- Open the gas cock;
- 2.- connect the boiler to the electricity and set the general switch to ON (detail "T" in figure 17-1);
- 3.- The boiler ignites only when the temperature requested by the room thermostat is higher than the present delivery temperature. Adjust the desired temperature for the heating service using the  and  keys. If the outdoor sensor is connected (see section 13.1.4), check that the temperature calculated (see section 17.14, parameter **1012** or parameter **1107** for appliances from 115T to 280T) is higher than the present heat exchanger temperature and the outdoor temperature (see section 17.14 parameter **1004**) is lower than the outdoor temperature for switching off the central heating (see section 17.15 parameter **2020**);
- 4.- If the boiler is connected to a storage tank (see section 13.2) press keys  and  to select the desired domestic hot water temperature.
- 5.- If the display indicates a low water pressure error (see section 17.16.2), repeat the operation to bleed the air.

16.6.2 - AGUADENS hot water heater ignition

- 1.- Open the gas cock;
- 2.- connect the boiler to the electricity and set the general switch to ON (detail "T" in figure 17-1);
- 3.- The boiler ignites only when the temperature set is higher than the present input temperature. Adjust the desired temperature for the input using the  and  keys.
- 4.- If the display indicates a low water pressure error (see section 17.16.2), repeat the operation to bleed the air.

16.7 - Controlling the supply gas pressure and any adjustments

The gas supply pressure must match that shown in the table in section 19. Proceed as follows to verify the pressure:

- 1.- Close the gas cock;
- 2.- access the boiler's internal parts by following the procedure described in section 18.2;
- 3.- loosen tapping point "D" (see Figure 16-6);
- 4.- connect a pressure gauge with a resolution of at least 0.1 mbar (1 mmH₂O) to it, for models from 140T to 280T you can use any of the valves present;
- 5.- turn on the gas cock;
- 6.- check that the pressure does not exceed 45 mbar;
- 7.- position the general switch to ON (detail "T" in figure 17-1) and trigger a demand for heating by pressing key  up to the maximum value, check that the temperature set is higher than the output temperature and that the system is in the right conditions to disperse the heat generated;
- 8.- Set parameter **2200** at **H 10H** (in models 60T and 70T use parameter **2010**). Now the burners will operate at maximum power for 20 minutes;
- 9.- with the boiler at maximum capacity, check that the gas supply pressure does not fall below 10 mbar (100 mmH₂O). If the pressure is lower, do not try to make any adjustments to the boiler, instead you must act upstream from it to restore the correct pressure and flow of gas.



WARNING! Do not touch screws "E" and "F" in figure 16-10, these are factory set for the correct flow of gas and the correct output pressure.

After verifying the gas pressure is correct:

- 1.- Reset parameter **2200** to **OFF** (in models 60T and 70T use parameter **2010**);
- 2.- turn off the gas cock;
- 3.- disconnect the pressure gauge and reclose the tapping point "D";
- 4.- check for any possible gas leaks from tapping point "D" (figure 16-6);

 Do not force the screws to close the tapping points in order to avoid damaging the gas valve.



WARNING! Test the gas seal using a soap and water solution only. The use of naked flames is prohibited.

16 - START-UP

16.8 - Controlling the level of CO₂ and any adjustments

Table 16-8 shows the correct values of CO₂ for a boiler working in normal conditions, at an altitude of less than 1000 metres. A different value from the one shown can cause malfunctions. A combustion analysis must be carried out to check and make any necessary adjustment to this value. Proceed as follows:

16.8.1 - Check the CO₂ content and make any necessary adjustment on boiler models 70T

 **WARNING!** If during this procedure a CO value of more than 1000 ppm is detected, turn off the boiler and contact the dealer.

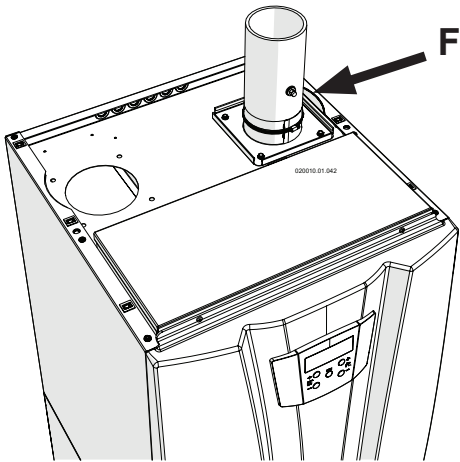

F - Taking combustion analysis
Figure 16-9 - Taking combustion analysis

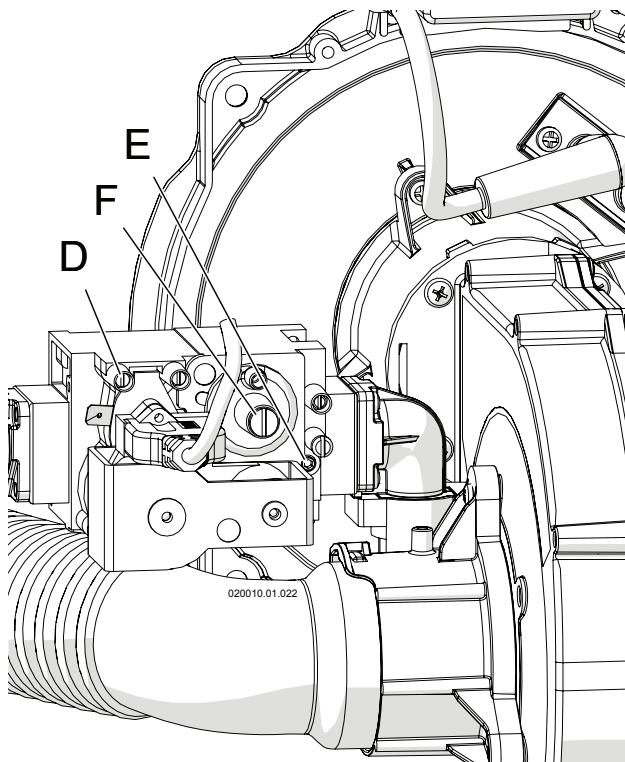

D - Gas inlet tapping point.
E - CO₂ regulation screw.
F - Factory regulation screw (do not touch).

Figure 16-10 – Gas valve

- 1.- If one is not already present, you will have to make a hole for the combustion analysis, located about 200 mm from the exhaust gases outlet pipe (see figure 16-9 corresponding to stopper "F").
- 2.- Turn on the boiler and open the link between terminals "10" and "11";
- 3.- Make sure that the temperature demanded is higher than that of the boiler/hot water heater;
- 4.- Go into the installer menu (see section 17.15) and set parameter **20 10** to **HIGH**. Now the boiler will operate at maximum power for 20 minutes;
- 5.- Wait two or three minutes for the CO₂ to stabilise;
- 6.- Insert the sensor to read the value of CO₂ in point "F" shown in figure 16-9;
- 7.- Compare the value of CO₂ detected with that shown in table 16-8; make sure you read the value for the type of gas being used. If the value of CO₂ is not that shown in table 16-8, you must correct it using screw "E" in figure 16-10. Using a 2.5 mm six-sided spanner (turn the screw clockwise to reduce the value of CO₂ and anticlockwise to increase it), make small turns, always waiting for the CO₂ value to stabilise before continuing with further movements, until you reach the desired value.
- 8.- Once you have reached the correct value of CO₂ as in table 16-8, seal the screw with red paint or a similar system to discourage any tampering with it.
- 9.- Set parameter **20 10** at **LO**. The boiler will now operate at minimum power for 20 minutes.
- 10.- Wait two or three minutes for the CO₂ to stabilise;
- 11.- Compare the reading for the value of CO₂ with that shown in table 16-8, make sure you read the value for the type of gas being used. The value of CO₂ must fall within the values shown, if that is not the case you must turn off the boiler and contact the manufacturer.
- 12.- Set parameter **20 10** to **OFF** to return the boiler to normal operation.
- 13.- Close the combustion analysis hole in figure 16-9, with a suitable stopper "F" as shown in the manufacturer's instructions for the outlet pipe.

 **WARNING!** Once stopper "F" is in position with the boiler at maximum power, check there are no leaks of exhaust gases.

16.8.2 - Check the CO₂ content and make any necessary adjustment on boiler models 140T to 280T



WARNING! If during this procedure a CO value of more than 1000 ppm is detected, turn off the boiler and contact the manufacturer.

- 1.- If one is not already present, you will have to make a hole for the combustion analysis, located about 200 mm from the exhaust gases outlet pipe (see figure 16-9 corresponding to stopper "F").
- 2.- Turn on the boiler and open the link between terminals "10" and "11";
- 3.- Make sure that the temperature demanded is higher than that of the boiler/hot water heater;
- 4.- Go into the installer menu (see section 17.15 and set parameter **2201** to **HIGH**. Now the MASTER burner will operate at maximum power for 20 minutes;
- 5.- Wait two or three minutes for the CO₂ to stabilise;
- 6.- Insert the sensor to read the value of CO₂ in point "F" shown in figure 16-9;
- 7.- Compare the value of CO₂ detected with that shown in table 16-8; make sure you read the value for the type of gas being used. If the value of CO₂ is not as shown in table 16-8, you must correct it using screw "E" in figure 16-10. Using a 2.5 mm six-sided spanner (turn the screw clockwise to reduce the value of CO₂, or anticlockwise to increase it), make small turns, always waiting for the value to stabilise before continuing with further movements, until you reach the desired value.
- 8.- Once you have reached the correct value of CO₂ as in table 16-8, seal the screw with red paint or a similar system to discourage any tampering with it.
- 9.- Set parameter **2201** to **LO**. Now the MASTER burner will operate at minimum power for 20 minutes.
- 10.- Wait two or three minutes for the CO₂ to stabilise;
- 11.- Compare the reading for the value of CO₂ with that shown in table 16-8, make sure you read the value for the type of gas being used. The value of CO₂ must fall within the values shown, if that is not the case you must turn off the boiler and contact the manufacturer.



WARNING! The CO₂ reading at minimum power could be influenced by the chimney draught. This is deduced when the CO₂ value is rather low compared to the value at high power. In this event it is necessary to take the CO₂ reading by removing the flue gas sensor from the corresponding burner and inserting the analyser sensor into the hole

- 12.- Set parameter **2201** to **OFF**;
- 13.- Work on the remaining burners, repeating the steps from point "3" to point "11", bearing in mind that parameter **2202** acts on burner 2, **2203** on burner 3 and **2204** on burner 4.
- 14.- Close the combustion analysis hole in figure 14-2, with a suitable stopper "F" as shown in the manufacturer's instructions for the outlet pipe.



WARNING! Once stopper "F" is in position with the boiler at maximum power, check there are no leaks of exhaust gases that could cause damage.

16.9 - Check boiler power

The boiler's air/gas mixture ratio is set at the factory. The gas pressure at the burner is controlled indirectly by the fan. The only way to check the boiler's power is to act directly on the gas meter. Proceed as follows:

1. Turn on the boiler by moving the general switch (detail "T" in figure 17-1) to ON and launch a heating request by setting the requested temperature to the maximum using key , making sure that the system is capable of dispersing all the heat generated.
2. For models 60T and 70T, set parameter **2010** to **HIGH**.
For the other models set parameter **2200** to **HIGH**, now the boiler will operate at maximum power for 20 minutes.
3. Measure the gas flow rate at the meter. The value obtained must be compared with the value given in section 19 under the heading "Gas flow rate" with a tolerance of +/- 10%.
4. If the gas flow rate is lower, check:
 - a) That there are no obstructions in the air intake and flue gas outlet ducts;
 - b) That the lengths of the air intake and flue gas outlet ducts correspond with what is shown in section 19;
 - c) That the air intake filter (detail "11" in figures 3-3, 3-5 and 3-7) is clean;
5. If the gas flow rate falls within this margin, set parameter **2200** to **OFF**. In boiler models 60T and 70T, set parameter **2010** to **OFF** to return the boiler to normal operation;
6. If the gas flow rate is higher, repeat the process described in section 16.9.

16.10 - Minimum water flow rate

The boiler has a system to protect against low water flow rate. The water flow rate gauge (detail "16" in figure 3-1) constantly measures the flow rate on each heat exchanger. If the flow rate falls below the value of the "Minimum operating water flow rate" described in section 19, the boiler will turn off automatically and, after three minutes, if the flow rate does not go up, the relative error will appear on the display.

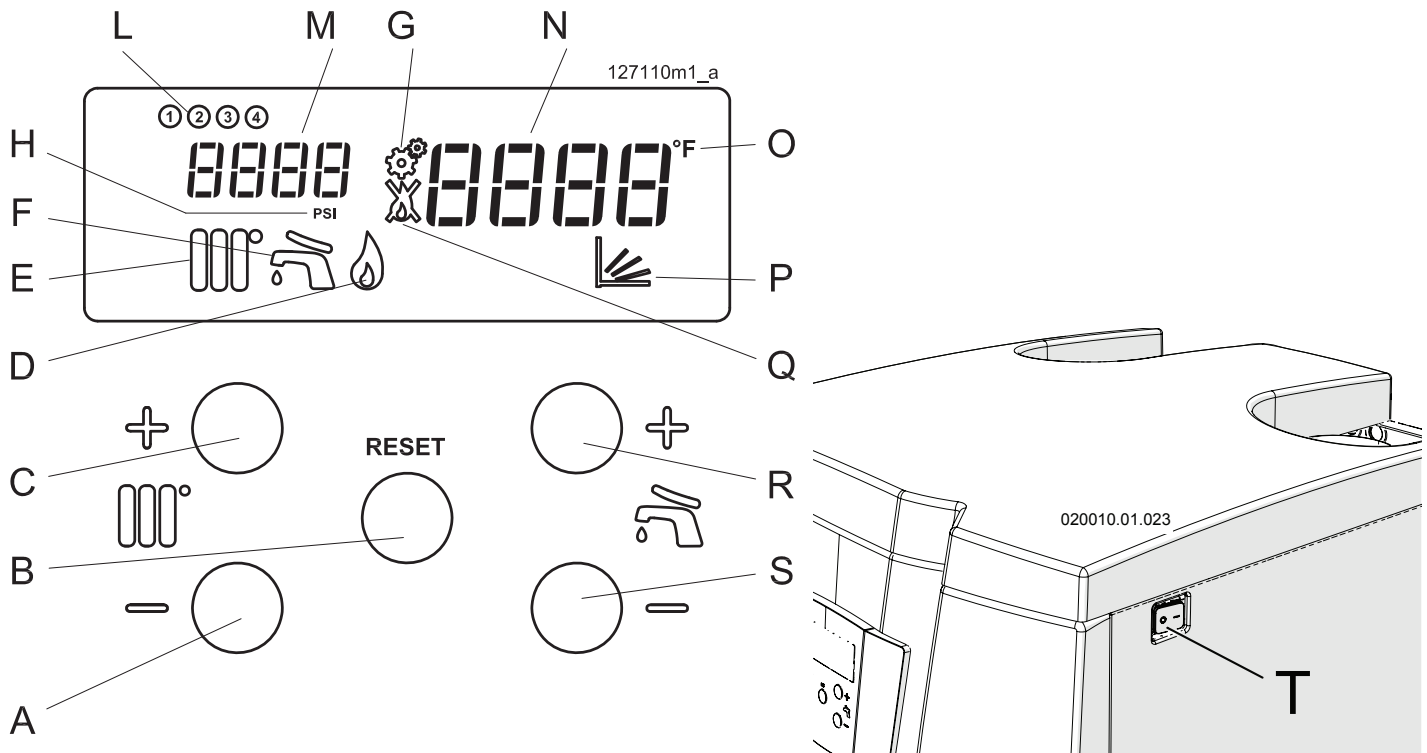

Figure 17-1 – Control board

FIGURE 17-1 KEY

- A - Button to reduce water temperature
- B - Multifunctional button Reset button and button to enter “user menu” and “installer menu”
- C - Button to increase water temperature
- D - Burner status
Icon off = burner off
Icon on = burner on
- E - Heating or domestic hot water service status:
Icon off = Service off
Icon on = Service active but not in operation
Flashing icon = Service active and in operation
- F - Domestic hot water service with puffer status:
Icon off = Service off
Icon on = Service active but not in operation
Flashing icon = Service active and in operation
- G - Icon to enter “installer menu”
- H - Unit of measurement of pressure displayed
- L - Burner unit indicator
① = Burner 1 (master)
② = Burner 2
③ = Burner 3
④ = Burner 4
- M - Water pressure or indicator of different parameters within the different menus
- N - Temperature of the central heating or domestic hot water or indicator of the values assumed by the various parameters
- O - Unit of measurement of the temperature displayed
- P - Central heating service adjusted by the external sensor
- R - Key for increasing the temperature of the domestic hot water with puffer and for scrolling through and changing the value of the parameters
- S - Key for reducing the temperature of the domestic hot water with puffer and for scrolling through and changing the value of the parameters
- T - On/off switch

17.1 - Water pressure check

17.1.1 - MYDENS boiler checking water pressure

If the pressure inside the central heating circuit falls below 0.5

bar, viewer “N” in figure 17-1 shows **Err 59** to indicate that it is necessary to restore correct pressure. To do this, proceed as follows:

- 1.- Open the device provided by the installer upstream of the appliance in order to fill the system;
- 2.- Check the pressure on display “M” in figure 17-1; it must reach a pressure of 1.5 bar (the **Err 59** message must disappear);
3. - Close the filling device provided by the installer upstream from the appliance.

WARNING! During normal operation the device provided by the installer upstream from the appliance for filling the system must always stay in the closed position. If the pressure drops over time, restore the correct value. This operation may have to be repeated several times in the first month of operation to remove any air bubbles in the system.

17.1.2 - AGUADENS hot water heater checking system pressure

If the pressure in the circuit falls below minimum pressure, the appliance turns off automatically and display “N” in figure 17-1

shows **Err 59** (see section 17.16.2) to indicate that the correct pressure must be restored. As the hot water heater is installed in an open circuit, the mains supply pressure must be checked or any pressure reducer installed upstream must

be adjusted. When the value is re-established **Err 59** disappears from the display.

17.2 - General information

The boiler leaves the factory set with standard parameters. However, it is possible to consult or make a series of modifications to the parameters via the "user menu" (section 17.14) and the "installer menu" (section 17.15). During operation, the display shows the boiler operating status as well as other information as indicated in section 17.16 (Diagnostics).

17.3 - Display

During normal operation further parameters can be consulted via the "User menu" (see section 17.14), useful for understanding how the boiler operates and for checking the last lockouts or errors that occurred.

After 5 minutes of normal operation, the display goes off completely to save energy. Just press any button to turn it back on. In the event of an anomaly, the display comes back on automatically. This function can be modified by following section 17.13 (Energy saving).

17.4 - Ignition and switch-off procedure

To turn on the boiler, do the following:

- 1.- Open the gas cock;
- 2.- Power the boiler electrically;
- 3.- If the display shows **Err ES**, that indicates that live and neutral polarity has not been observed (call customer support to resolve the problem without trying to take any action yourself).
- 4.- Adjust the domestic hot water (where present) temperature and the central heating temperature as per sections 17.5, 17.6 and 17.7 respectively.

The command and control equipment will switch the burner on. If the boiler does not ignite with 3 minutes, it will automatically try five times to ignite again. If it still will not ignite, it is locked out and the display will show **L O C** together with the icon , and the icon for the corresponding burner ① ② ③ ④ will flash. Press the RESET button to restore normal operating conditions. The boiler will automatically attempt to ignite again.

 **WARNING! If shutdown due to lockout occurs frequently, contact a qualified technician to restore normal operating conditions.**

Once the boiler has started up correctly it will continue to operate for the service required.

To turn off the boiler, do the following:

- 1.- Use switch "T" in figure 17-1 to remove electrical voltage;
- 2.- turn off the gas cock;

17.5 - AGUADENS hot water heater adjusting the temperature



To adjust the temperature use keys  or  (see

figure 17-1). When the keys are pressed the display, detail "N" in figure 17-1, shows the temperature requested. The temperature of instant domestic hot water can be set to between 20°C and 80°C.



WARNING! A domestic hot water temperature of more than 51°C can cause scalds. Children, the disabled and the elderly are at high risk of scalds. Check the temperature of the water before getting into the bath or shower.

17.6 - MYDENS boiler adjusting the domestic hot water

If the boiler is installed to perform a dual function (central heating and the production of domestic hot water), the domestic hot water temperature can be adjusted using keys





(see figure 17-1). When the keys are pressed the display, detail "N" in figure 17-1, shows the DHW temperature requested. The temperature can be set to between 40°C and 60°C.



WARNING! A domestic hot water temperature of more than 51°C can cause scalds. Children, the disabled and the elderly are at high risk of scalds. Check the temperature of the water before getting into the bath or shower.



17.7 - MYDENS boiler adjusting the central heating

The boiler's central heating temperature can be adjusted

using buttons  or  (see figure 17-1). The room thermostat turns on the circulation pumps so as to satisfy the requirements for heating.

17.8 - Thermostatic adjustment of central heating

The boiler is factory set with parameter **2003** at **0**, i.e. the boiler supplies hot water to the central heating system

at a temperature adjusted using the  or  keys. Any room thermostat enables or disables the central heating function to adjust the temperature in the rooms. To make full use of the boiler efficiency, adjust the central heating temperature to a value that is just sufficient to obtain the desired temperature in the rooms. If the season gets colder, progressively increase the value of the central heating temperature. Proceed in reverse order when the season goes towards warmer temperatures.

17.9 - Climate control

Via the "Installer menu" adjust parameter **2003** to **1**. The central heating delivery temperature is related to the outdoor temperature sensor according to the algorithm in figure 17-2. To adapt the calculation line to the various homes/climatic conditions, all adjustment parameters must be set according to the following sections.

17.9.1 - Climate control: setting the parameters

Via the "Installer menu" (see section 17.15), set:

- **2020** = "Heating off outdoor temperature", adjustable to between 0°C and 35°C. When the outdoor temperature reaches the value set under this parameter, the central heating is switched off automatically. The central heating switches back on automatically when the outdoor temperature drops back to below this value. The recommended start value is 22°C.
- **2021** = the "Projected outdoor temperature (winter)", adjustable to between -20°C and 5°C. This is the outdoor temperature used to define the heat input required by the system. The recommended start value for a typical home is -5°C;
- **2022** = the "Delivery temperature corresponding to projected outdoor temperature (winter)", adjustable to between 0°C and 80°C. The delivery temperature assumes the value set under this parameter when the outdoor temperature corresponds to that set under parameter **2021**. The recommended start values are: 40°C for low-temperature systems (underfloor heating); 70°C for high-temperature systems (radiators);
- **2023** = "Outside spring temperature", adjustable to between 0°C and 30°C. This is the outdoor temperature at which the central heating is to reach the minimum supply temperature. The recommended start value is 18°C;
- **2024** = the "Delivery temperature corresponding to projected outdoor spring temperature", adjustable to between 0°C and 40°C. The delivery temperature assumes the value set under this parameter when the outdoor temperature corresponds to that set under parameter **2023**. The recommended start values are: 30°C for low-temperature systems (underfloor heating); 42°C for high-temperature systems (radiators);
- It is also possible to set the minimum and maximum central heating temperatures using the respective parameters **3016** and **3015** in section 20.

If, for any reason, the central heating service does not correspond to the load, use parameters **2022** (Delivery temperature corresponding to outdoor projected temperature (winter)) to increase or lower the temperature calculated and match the desired room temperature.

17.9.2 - Climate control: switching the central heating service on and off

The climate control service is completely automatic, including switch-off at the end of the season and switch-on at the start of the next season via parameter **2020**. When the outside temperature rises above the value set under this parameter, the central heating switches off automatically. When the

outside temperature drops back below the value set under this parameter, the central heating service switches back on automatically.

17.10 - Time settings for the various functions

To protect the lifespan of the appliance, improve comfort, and increase energy savings, timers have been introduced during operation. These time settings are as follows:

- Pump post-circulation: every time the room thermostat determines the end of the central heating service, the pump continues to operate for 4 minutes;
- Pump anti-block function: every 24 hours, the central heating pump and the domestic hot water pump (if present) are forced;
- Ignition delay: In all operating modes, every time the burner switches off, it waits 3 minutes before it ignites again.

17.11 - Pump anti-blocking

During the summer, the pump switches on once every 24 hours for 15 seconds in order to prevent any deposits from blocking it. The diverter valve and the storage tank pump (if present) are activated at the same time for the same reason.

17.12 - Anti-freeze protection



WARNING!

For the anti-freeze protection to be effective, the appliance must be left with the electrical power supply and gas supply present and the two services (domestic hot water and central heating) in the **OFF** position.



WARNING!

The anti-freeze protection service offered by the boiler cannot guarantee anti-freeze protection of the central heating system, the domestic hot water system or the building itself, or a part of the same.

The central heating pump starts automatically when the boiler temperature reaches 10°C. If the temperature drops further to below 5°C, the burner also ignites to protect the boiler from the effects of freezing.

If the boiler is not used for a long period of time (over a year), empty it following the procedure in section 18.10.

17.13 - Energy Saving

To reduce energy consumption by the display (Figure 17-1), 5 minutes after the last operation carried out it will automatically turn off. This function can be deactivated or the time can be changed using parameter **2100** that is in the "installer menu" (section 17.15). If you set the parameter at **0**, the display will remain constantly on.

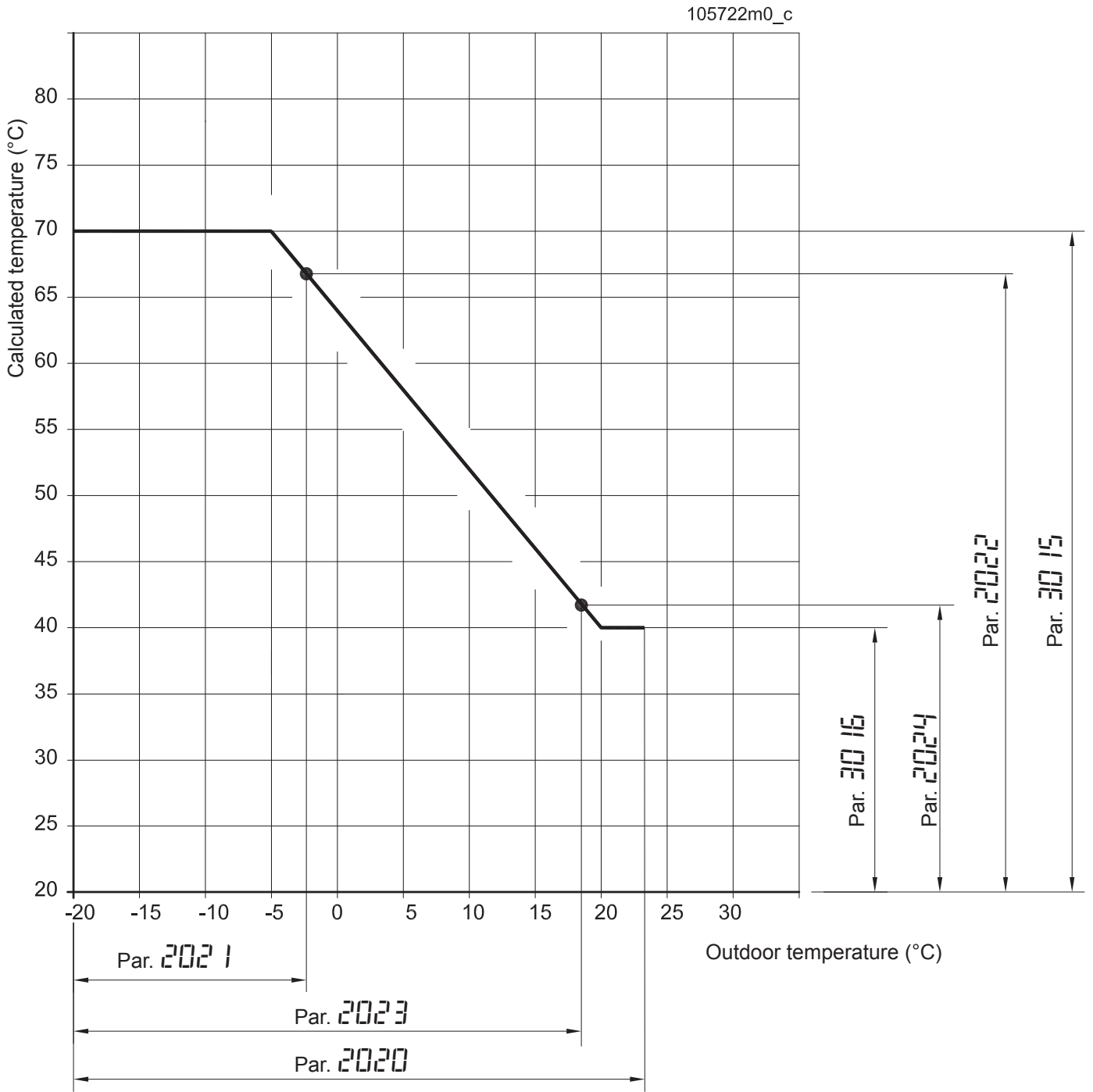

- Par. 2020 = outdoor temperature for heating switch-off
- Par. 2021 = projected outdoor temperature (winter)
- Par. 2022 = delivery temperature corresponding to projected outdoor temperature (winter)
- Par. 2023 = Outdoor spring temperature
- Par. 2024 = delivery temperature corresponding to projected outdoor spring temperature
- Par. 30 16 = Minimum delivery temperature
- Par. 30 15 = Maximum delivery temperature

Figure 17-2 - Graph of climate control

17 - USE

17.14 - "User menu"

Press the RESET button for 2 seconds to enter the "user menu". Viewer "M" in figure 17-1 begins to show parameter

1001 to indicate the change of mode to the user.

Using buttons  + and  - it is possible to scroll through the parameters contained in the menu.

To exit the menu just press the RESET button for 2 seconds again.

If no button is pressed for more than 60 seconds, the menu is exited automatically.

For models from 100T to 280T, all the parameters indicated as "Burner 1" refer to the boiler's Master Burner, to display these parameters for the other burners, connect the display to the burner in question as shown in section 18.8.

The following parameters can be examined in this menu:

Parameter	Description of parameter	U.M.
1001	Burner 1 - Water output temperature	°C
1002	Puffer tank temperature (if present)	°C
1004	Outdoor temperature (visible when an outdoor temperature sensor is installed)	°C
1006	Burner 1 - Flue gas temperature	°C
1007	Burner 1 - Return temperature	°C
1008	Burner 1 - Ionisation current	uA
1009	Burner 1 - Status of primary circuit pump and motorised valve	ON/OFF
1010	Status of heating circuit pump	ON/OFF
1011	Status of domestic hot water circuit	ON/OFF
1012	Heating setpoint calculated (with external sensor enabled) (only for models 60T and 70T. For other models see Parameter 1107)	°C
1040	Burner 1 - Present rotation speed of fan	revs/min
1041	Burner 1 - Rotation speed of fan at ignition	revs/min
1042	Burner 1 - Rotation speed of fan with minimum power	revs/min
1043	Burner 1 - Rotation speed of fan with maximum power	revs/min
1051	Burner 1 - Last lockout (Loc) recorded (see section 17.16.1) **	/
1052	Burner 1 - Last error (Err) recorded (see section 17.16.2) **	/
1053	Burner 1 - Number of times that the burner flame has gone out	n°
1055	Burner 1 - Number of failed ignitions of burner	n°
1056	Burner 1 - Number of hours worked	h x 10
1057	Burner 1 - Number of hours worked on domestic hot water with puffer tank	h x 10
1059	* Time interval between the last two lockouts (Loc)	1: value in minutes; 2: value in hours; 3: value in days; 4: value in weeks;
1060	* Time interval between the last two errors (Err)	
1062	Burner 1 - Water flow rate	l/min
1101	Multi-burner: Number of burners on	n°
1102	Multi-burner: Manifold temperature	°C
1103	Multi-burner: Number of burners locked out (Loc)	n°
1104	Multi-burner: Number of burners showing Error (Err)	n°
1106	Multi-burner: Boiler in emergency mode	Yes/Not
1107	Multi-burner: Heating setpoint calculated (only mod 100T, 115T, 140T, 210T and 280T) (for other models see Parameter 1012)	°C
1120	Multi-burner: Burner 1 modulation level	%
1121	Multi-burner: Burner 2 modulation level	%
1122	Multi-burner: Burner 3 modulation level	%
1123	Multi-burner: Burner 4 modulation level	%

* How to read the values of parameters 1059 and 1060:

E.g. If it shows 1:29, it means 29 minutes;
E.g. If it shows 2:12, it means 12 hours;
E.g. If it shows 3:15, it means 15 days;
E.g. If it shows 4:26, it means 26 weeks.

** If the number 255 is displayed it means that there has been no lockout or error.

17.15 - "Installer menu"



WARNING! Changing these parameters could cause boiler and therefore system malfunctions. For this reason only a technician with the awareness and in-depth knowledge of the boiler can change them.

The boiler's command and control board makes available to the technician this menu of parameters, for analysis of operation and adaptation of the boiler to the system. To go into the "installer menu", proceed as follows:

- 1.- hold down the RESET button and together for 5 seconds until parameter **2001** is displayed. The symbol appears in the centre of the display, to indicate entry into the "installer menu".
- 2.- within the menu it is possible to scroll through the parameters using buttons + and -;
- 3.- once the parameter concerned is displayed you can change it in this way:
 - a.- press the RESET button to enter into the parameter (viewer "N" in figure 17-1 will start to flash);

- b.- Edit the value of the parameter using the + and - keys;
 - c.- Press the RESET key to confirm the change and go back to the list of parameters;
- 4.- To exit the "installer menu" hold down the RESET button for 5 seconds until symbol disappears from the display.

If no button is pressed for more than 60 seconds, the menu is exited automatically. Any change to the data that is not confirmed with the RESET button will be lost.

For models from 100T to 280T the parameters indicated as "Burner 1" refer only to Burner 1 (Master). To display or change these parameters for the other burners, connect the display to the burner in question as shown in section 18.8.



WARNING! Any variations made to the parameters must be noted in the "Customised values" column in the following table, in order to facilitate any future replacements of the command and control board.

The following parameters can be changed or examined in this menu:

Parameter	Description of parameter	U.M.	Setting range	MYDENS factory value	AGUA-DENS factory value	Customised values
2001	Central heating minimum power level	%	From 1 to 50	1	1	
2002	Central heating maximum power level	%	From 1 to 100	100	100	
2003	Central heating operating mode	nn	0 = Room Thermostat 1 = External sensor with room thermostat 2 = External sensor room thermostat off reduces 2027 3 = Constant heating room thermostat off reduces 2027 4 = 0-10 Volt input 5 = N/A	00	00	
2004	Waiting time after maximum differential	secs	From 10 to 30	30	30	
2005	Post circulation heating pump	secs	From 10 to 260	240	240	
2010	Burner 1 - Burner forcings	/	Off = No forcing Low = Minimum power Ign = Ignition power High = Maximum power	OFF	OFF	
2011	Forcing of primary circuit pump and 2-way motorised valve (Burner 1)	/	On or Off	OFF	OFF	
2012	Forcing of heating circuit pump	/	On or Off	OFF	OFF	
2013	Forcing of domestic hot water circuit pump	/	On or Off	OFF	OFF	
2014	Test icons on display. Pressing the RESET button turns on all the icons on the display. Pressing the RESET button again returns the display to normal operation	/	/	/	/	
2020	Climate control: outdoor temperature for heating switch-off	°C	From 0 to 35	22	N/A	
2021	Climate control: project outdoor temperature (winter)	°C	From -20 to 5	-5	N/A	
2022	Climate control: delivery temperature corresponding to project outdoor temperature (winter)	°C	From 0 to 80	80	N/A	
2023	Climate control: spring project outdoor temperature	°C	From 0 to 30	20	N/A	



17 - USE

2024	Climate control: delivery temperature corresponding to spring outdoor temperature	°C	From 0 to 40	40	N/A	
2027	Night-time reduction	°C	From 0 to 50	10	N/A	
2040	N/A	N/A	N/A	N/A	N/A	
2041	N/A	N/A	N/A	N/A	N/A	
2042	Burner 1 - Protection against frequent ignitions: time	secs	From 10 to 900	180	180	
2043	Burner 1 - Protection against frequent ignitions: temperature differential	°C	From 0 to 20	16	5	
2062	Post circulation domestic hot water pump	secs	From 10 to 255	240	240	
2063	Maximum time priority DHW	min	From 1 to 60	30	N/A	/
2067	Priority production of DHW	/	0 = Priority lasts the time set at parameter 2063; 1 = OFF, the domestic hot water does not have priority over central heating; 2 = ON, the domestic hot water always has priority over central heating;	2	N/A	
2100	Energy saving display	min	From 0 to 30 = delay in switching off in minutes.	5	5	
2101	Multi-burner: emergency mode	/	Yes or No	Yes	Yes	
2102	Multi-burner: Emergency temperature adjustment	°C	from 20 to 65	45	45	
2103	Multi-burner: ignition delay	secs	from 1 to 900	15	15	
2104	Multi-burner: switch-off delay	secs	from 1 to 900	15	15	
2105	Multi-burner: delta temp. burner ignition	°C	from 0 to 20	5	5	
2106	Multi-burner: delta temp. burner switch-off	°C	from 0 to 20	5	5	
2107	Multi-burner: maximum increase in temp. compared to that calculated	°C	from 0 to 20	10	4	
2108	Multi-burner: maximum reduction in temp. compared to that calculated	°C	from 0 to 20	20	4	
2109	Multi-burner: Next burner ignition	%	from 1 to 100	70	70	
2110	Multi-burner: Next burner switch-off	%	from 1 to 100	10	10	
2111	Multi-burner: Burner rotation	gg	from 0 to 9	6	6	
2113	Multi-burner: Modulation start-up delay	min	from 0 to 60	5	0	
2114	Burner 1: Primary circuit pump switch-off time	secs	from 0 to 255	240	240	
2200	Forcing: All Burners together.	\	Off, Low, Ign, High	OFF	OFF	
2201	Forcing: Burner 1 (Master).	\	Off, Low, Ign, High	OFF	OFF	
2202	Forcing: Burner 2.	\	Off, Low, Ign, High	OFF	OFF	
2203	Forcing: Burner 3.	\	Off, Low, Ign, High	OFF	OFF	
2204	Forcing: Burner 4.	\	Off, Low, Ign, High	OFF	OFF	

N/A = Not Applicable

17.16 - Diagnostics

During normal operation of the boiler, viewer "N" in figure 17-1 continuously shows the boiler's work status, by means of the following indications:

Parameter	Description of parameter	Display on screen "N" in Figure 17-1
 RFRD	Anti-frost function on	Boiler temperature (°C)
	DHW with puffer operation status	Temperature of DHW (°C)
	Operation status of central heating or instant DHW	Output temperature (°C)

17.16.1 - Diagnostics: lockouts "Loc"

Lockout	Lockout description	Checks	Solutions
Loc 1	No detection of flame after five successive attempts to ignite.	A - Gas supply pressure (see section 16.7); B - Sparks on ignition electrodes (see section 18.5); C - Correct gas pressure and CO2 value (see sections 16.7 and 16.8); D - Electric power supply of 230 Vac to gas valve; E - Electrical resistance of the two coils of the gas valve of 0.88 Kohm and 6.59 Kohm F - If the burner comes on and goes off at the end of the ignition attempt, check: that the ionisation current is at a value of more than 4 (follow the procedure in section 18.12)	A - If the pressure is not correct it must be reset working upstream of the boiler; B - Check and correct the electrodes position (section 18.5); C - Get rid of any blockage in the air intake and flue gas outlet ducts; D - If the power supplied to the gas valve is not at 230 Vac replace the control board; E - If the resistance does not correspond, replace the gas valve; F - If the ionisation current does not correspond, check the CO2 as shown in section 16.8. Check the good order of the detection electrode and if necessary replace it and check the good order of the cable connecting the detection electrode and if necessary replace it.
Loc 2 (*)	Gas valve not supplied during ignition attempts	A - Check intervention of delivery safety thermostat; B - Check intervention of exhaust gases safety fuse;	⚠WARNING! If the exhaust gases temperature safety fuse intervenes, before replacing it, contact the boiler manufacturer in order to avoid serious damage to the heat exchanger.
Loc 3	Gas valve loses electric power supply during operation	Check the good order of the electrical connections between gas valve and control board;	A - If the electrical connections are interrupted, reset them; B - If the connections are in good order try to replace the gas valve or the control board;
Loc 4	Gas valve relay doesn't close	Check the good order of the electrical connections between gas valve and control board;	A - If the electrical connections are interrupted, reset them; B - If the connections are in good order try to replace the gas valve or the control board;
Loc 5 (*)	Gas valve circuit	A - Check intervention of delivery safety thermostat; B - Check intervention of exhaust gases safety fuse;	⚠WARNING! If the exhaust gases temperature safety fuse intervenes, before replacing it, contact the boiler manufacturer in order to avoid serious damage to the heat exchanger.
Loc 6	Safety relay opening error		Replace the command and control board.
Loc 7	Safety relay closing error		Replace the command and control board.
Loc 11	Error of lockout for over 20 hours	Press the RESET button to see the type of error (Err) and then proceed;	
Loc 12	Fan error	A- Check power supply to fan 230 Vac; B - Check the PWM connection to the fan;	A - If the power supply is not correct, replace the control board; B - If there is no PWM fan dialogue, replace the control board; C - Try to replace the fan;
Loc 13	Software error inside control board		Replace the command and control board.
Loc 14	Software error inside control board		Replace the command and control board.
Loc 15	Software error inside control board		Replace the command and control board.
Loc 16	Software error inside control board		Replace the command and control board.
Loc 17	Software error inside control board		Replace the command and control board.
Loc 18	Software error inside control board		Replace the command and control board.
Loc 19	Software error inside control board		Replace the command and control board.

17 - USE

Loc 20	Flame lost three times	<p>Check: that the ionisation current is at a value of more than 4 (follow the procedure in section 18.12)</p> <p>Check that the flue gas exhaust is properly protected against obstructions caused by gusts of wind</p>	<p>If the ionisation current is not over 4, check the CO2 (see section 16.8) and restore it to the correct value. Check the ionisation spark plug and replace it if necessary. Check the integrity of the ionisation current electric circuit cables.</p> <p>If the flue gas outlet is positioned on a vertical wall it must be protected by an anti-wind grill; if the flue gas outlet is positioned on the roof, check that it isn't in a area where there is flowback, and that any anti-wind chimney that may be provided is really effective.</p>
Loc 21	Software error inside control board		Replace the command and control board.
Loc 22	Software error inside control board		Replace the command and control board.
Loc 23	Software error inside control board		Replace the command and control board.
Loc 24	Software error inside control board		Replace the command and control board.
Loc 25 (*)	Gas valve circuit	<p>A - Check intervention of central heating delivery safety thermostat;</p> <p>B - Check intervention of exhaust gases temperature safety fuse;</p>	<p>⚠WARNING! If the exhaust gases temperature safety fuse intervenes, before replacing it, contact the boiler manufacturer in order to avoid serious damage to the heat exchanger.</p>
Loc 26	Software error inside control board		Replace the command and control board.
Loc 27	Flame present with gas valve closed		Replace the gas valve
Loc 28	Flame present with gas valve closed		Replace the gas valve
Loc 29 (*)	Flue gas outlet pressure switch circuit or external safety devices	<p>A - Check the connection to the external safety device;</p> <p>B - Check intervention of exhaust gases differential pressure switch;</p> <p>C - Check for any possible blockage of flue gas outlet;</p>	<p>A - Check external safety devices connected to terminals 103 and 104.</p> <p>B - Check the pressure switch against the flue gas outlet blockage and if necessary replace it.</p> <p>C - Get rid of any possible blockages of flue gas outlet.</p>
Loc 30	Software error inside control board		Replace the command and control board.
Loc 31	Flame lost three times	<p>A - Check detection electrode;</p> <p>B - Check that the flue gas outlet is suitably protected from blockages caused by gusts of wind.</p> <p>C - Check for any possible recirculation of exhaust gases</p>	<p>A - Try to replace detection electrode.</p> <p>B - Check and if necessary get rid of any blockage in the air intake and exhaust gases outlet ducts.</p> <p>C - Look for the cause of the exhaust gases recirculation</p>
Loc 32	Software error inside control board		Replace the command and control board.
Loc 33	Software error inside control board		Replace the command and control board.
Loc 34	Software error inside control board		Replace the command and control board.
Loc 35	Software error inside control board		Replace the command and control board.
Loc 36	Software error inside control board		Replace the command and control board.
Loc 37	Software error inside control board		Replace the command and control board.
Loc 38	The flue gas sensor does not increase in temperature when the burner ignites	<p>a - Check that the flue gas sensor meets the requirement of section 18.14.</p> <p>b - Check that the flue gas sensor (parameter 1006) increases in temperature when the burner ignites.</p>	<p>a - If the flue gas sensor does not meet the requirements of section 18.14, it must be replaced.</p> <p>b - If the temperature does not increase, replace the exhaust gas temperature sensor or the command and control board.</p>

(*) = This error locks out all the burners

17.16.2 - Diagnostics: errors "Err"

Error	Error description	Checks	Solutions
Err 0	A sensor is outside the field of measurement	Check that all the temperature sensors are in a plausible field of measurement	Replace the sensor that is not in the correct temperature field or replace the main board
Err 45	Software error inside control board		Replace the command and control board.
Err 46	Software error inside control board		Replace the command and control board.
Err 47	Software error inside control board		Replace the command and control board.
Err 48	Software error inside control board		Replace the command and control board.
Err 49	Software error inside control board		Replace the command and control board.
Err 50	Software error inside control board		Replace the command and control board.
Err 51	Software error inside control board		Replace the command and control board.
Err 52	Software error inside control board		Replace the command and control board.
Err 53	Software error inside control board		Replace the command and control board.
Err 54	Flame heard at a time when it shouldn't be there		Replace the command and control board.
Err 55	Low water pressure error	Check the status of the pressure gauge	Replace the pressure gauge.
Err 56	Low water pressure error	Check the status of the pressure gauge	Replace the pressure gauge.
Err 57	Low water pressure error	Check the status of the pressure gauge	Replace the pressure gauge.
Err 58	Low water pressure error	Check the status of the pressure gauge	Replace the pressure gauge.
Err 59 (*)	Low water pressure error	Check the system's pressure and if necessary increase it.	If the pressure detected is higher than that in parameter 3022, replace the pressure gauge.
Err 60	Exhaust gases high temperature error	A - Check the combustion efficiency of the burner the error is flagged up against, efficiency must be above that required by regulations. B - Check that the exhaust gases temperature sensor's resistance matches the graph in section 18.14.	A - If the efficiency is lower than that required by regulations, try to clean the exhaust gases side and water side of the heat exchanger. B - If the sensor doesn't match it must be replaced.
Err 61	Return temperature higher than delivery temperature	Check that the electrical resistance of the return sensor matches the graph in section 18.14.	If the sensor does not match, it must be replaced.
Err 62 (*)	Error in condensate level sensor	A - Check that the condensate outlet duct is not blocked; B - Check the status of the condensate neutraliser;	A - Clear the condensate outlet duct of any blockages; B - Replace the product contained in the condensate neutraliser;
Err 64	Error in frequency signal or error in WD communication	A - Check the frequency of the signal. It must be between 55 and 65 Hz. B - Check the earthing and that neutral is at 0 volt	A - If the frequency doesn't fall between the values, ask the electricity supplier. Otherwise, try to replace the control board. B - If the neutral isn't at zero, the correct electric power supply must be restored. If the neutral is at 0 Volt, try to replace the control board.
Err 65	Inverted polarity between live and neutral.	Check the correct polarity between live and neutral.	Invert the polarity between live and neutral.
Err 66	Frequency signal error	A - Check the frequency of the signal. It must be between 55 and 65 Hz. B - Check the earthing and that neutral is at 0 volt	A - If the frequency doesn't fall between the values, ask the electricity supplier. Otherwise, try to replace the control board. B - If the neutral isn't at zero, the correct electric power supply must be restored. If the neutral is at 0 Volt, try to replace the control board.

17 - USE

Err 67	Earthing error	Check the boiler is correctly earthed.	Restore the correct earthing to the boiler.
Err 68	Communication watch-dog error		Replace the command and control board.
Err 72	Delivery sensor open Exchanger malfunction	Check that the electrical resistance of the sensor matches the graph in section 18.14. Check that the primary heat exchanger temperature fuse has not intervened.	If the sensor does not match, it must be replaced. If the primary heat exchanger temperature fuse has intervened (the contact is open), the exchanger must be replaced
Err 73	Return sensor open	Check that the electrical resistance of the sensor matches the graph in section 18.14.	If the sensor does not match, it must be replaced.
Err 76	DHW sensor open	Check that the electrical resistance of the sensor matches the graph in section 18.14.	If the sensor does not match, it must be replaced.
Err 80	Delivery sensor short circuit	Check that the electrical resistance of the sensor matches the graph in section 18.14.	If the sensor does not match, it must be replaced.
Err 81	Return sensor short circuit	Check that the electrical resistance of the sensor matches the graph in section 18.14.	If the sensor does not match, it must be replaced.
Err 84	DHW sensor short circuit	Check that the electrical resistance of the sensor matches the graph in section 18.14.	If the sensor does not match, it must be replaced.
Err 86	Flue gases sensor short circuit	Check that the electrical resistance of the sensor matches the graph in section 18.14.	If the sensor does not match, it must be replaced.
Err 87	RESET button error	RESET button pressed too many times in 60 seconds	
Err 93	Boiler selection error	Check list of parameters 3000 (section 20)	
Err 107	Software error inside control board		Replace the command and control board.
Err 108	Software error inside control board		Replace the command and control board.
Err 109	Error at burners 2, 3 or 4	When burner 1 (MASTER) goes into general lockout, it turns off burners 2, 3 and 4, triggering error 109	Resolve error at burner 1 (Master).
Err 110	Flapper valve not open error		A - Check and if necessary get rid of any blockage in the air intake and flue gas outlet ducts; B - Check the flapper valve (detail 31 figure 3-2)
Err 111	Flapper valve not closed error		Check the flapper valve (detail 31 figure 3-2)
Err 112	Error relating to flapper inlet	Check that parameter 3005 is set at 0 or 4	If parameter 3005 is 0 or 4, replace the command and control board.
Err 113	Software error inside control board		Replace the command and control board.
Err 114	Water flow rate too low	Check the flow rate at the burner (parameter 1062), it must be greater than parameter 3035.	A - Increase the water flow rate at the system; B - Check and if necessary get rid of any blockage in the system.
Err 115	Master board error		Reset using parameter 3013.
Err 116 (*)	Communication error	A - BUS communication interrupted B - A burner is deprived of electric power supply	A - Check the BUS connection. B - Reset the electric power supply to all the burners
NO CONN	Microprocessor lockout	A - Check that the wires of the pressure gauge haven't short-circuited B - Check that the wires of the flow rate gauge haven't short-circuited C - Check that the display is connected to the MASTER	A - If it hasn't short-circuited replace the pressure gauge (or disconnect it using menu 3000). B - If it hasn't short-circuited replace the flow rate gauge (or disconnect it using menu 3000). C - If the display is not connected to the MASTER the words "NO-CONN" appear D - If none of the above cases apply, replace the control board and/or the display.

(*) = This error locks out all the burners

18 - MAINTENANCE

18.1 - General recommendations

This section must be brought to the user's attention by the installer, highlighting the tasks required to maintain correct operation of the system;

The installer must also inform the user that lack of care and maintenance of this boiler could cause malfunctions.

A regular annual maintenance check on the system is advised for the following reasons:

- to maintain high efficiency of the boiler and therefore save fuel;
- to maintain a high level of safety;
- to maintain the high level of combustion environmental compatibility;



WARNING! Appliance maintenance must be carried out only by a professionally qualified technician.



WARNING! Before any maintenance work, disconnect the appliance from the electrical power supply, using the relevant switch nearby.



WARNING! Before any maintenance operation turn off the gas cock

The operations to be carried out at each maintenance check are shown in the box below.

MAINTENANCE PROTOCOL

- Check there are no gas leaks
(See section 18.1.1);
- Check good order of air intake and flue gas outlet system (Follow section 18.1.2);
- Check the correct pressure of the water in the system
(See section 18.1.3);
- Check the ignition and detection electrodes
(See section 18.1.4);
- Cleaning the burner and the primary heat exchanger, flue gas side and checking good order of heat insulation devices
(Follow section 18.4)
- Clean air intake filter
(Follow section 18.6)
- Clean condensate outlet system
(Follow section 18.7).
- Check the appliance efficiency
(See section 18.13);

18.1.1 - Gas leak check

1. - Check for no gas leaks in the system;
2. - Check for any gas leaks using a gas leak detector (with bubble or similar), or equivalent system, carefully checking the whole gas pipe from the meter to the boiler.



WARNING! Do not carry out these checks in the presence of naked flames.

18.1.2 - Checking the condition of the air intake and flue exhaust ducts

1. - Check whether the air intake and flue gas outlet ducts have any blockages, signs of corrosion, physical damage, water marks or signs of rust.
2. - Make sure the externally assembled intake grids and flue exhaust outlets do not have any residue and are clean.

18.1.3 - Checking the system water pressure

1. - Check that the system is full of water and pressurised as reported in section 19 "Technical data".
2. - Check for leaks in the hydraulic connections.



WARNING! Remove any leaks from the system or the appliance. Continuously adding new water leads to increased minerals that reduce the cross-section of the passage, decreasing heat exchange and causing the heat exchangers to overheat. All of this leads to failures and reduces the appliance life.

18.1.4 - Checking the ignition and detection electrodes

1. - Remove the burner fan unit (as shown in section 18.3).
2. - Clean any material build-up from the electrodes.
3. - Make sure the electrodes are in the correct position as shown in section 18.5.

18 - MAINTENANCE

18.2 - Dismantling of cover and access to internal components



WARNING! If there is an external cover, take it off as shown in section 15

To dismantle the cover, proceed as follows (refer to Figure 18-1):

- 1.- Lift lid "A";
- 2.- Undo screws "B";
- 3.- Remove the front casing "C";
- 4.- Remove the lower casing "E";
- 5.- Open panel "D" by undoing the fixing screw located on the left and turning it as in the figure.
- 6.- Undo screw "G";
- 7.- Lift lid "F";

18.3 - Dismantling the burner fan assembly

To dismantle the burner fan assembly, proceed as follows:

- 1 - turn off the gas adduction cock and the electric power supply;

- 2.- access the boiler's internal parts by following the procedure described in section 18.2;
- 3.- dismantle the sparks generator "A" in Figure 18-2 by undoing screws "D" in Figure 18-2 and disconnecting it from the ignition spark plugs.
- 4.- dismantle air manifold "A" in Figure 18-3 by turning it clockwise and then taking it out leftwards;
- 5.- undo junction "H" in figure 18-4, paying attention to the gasket in the joint;
- 6.- with the help of a flat-head screwdriver, remove spring "A" in Figure 18-4;
- 7.- remove the electric plug from the gas valve;
- 8.- remove the gas valve by lifting it upwards, taking care with O-ring "L" (see figure 18-4);
- 9.- Undo the four nuts "B" in Figure 18-5;
- 10.- take out the fan/burner assembly (detail "C" in Figure 18-5).

Reassembly of fan/burner assembly

To reassemble the burner/fan assembly work backwards through the steps to dismantle it and bear in mind the following precautions:

- a - replace gasket "M" in Figure 18-4 taking care to clean the housing of this gasket thoroughly, as well as the bracket housing.
- b - check the status of the gasket on junction "H" and of O-ring "L" in Figure 18-4. If they are spoilt, replace them.
- c - Once everything is put back together, turn on the gas supply and carry out a seal test on junction "H" in Figure 18-4.



WARNING! Test the gas seal using a soap and water solution only. The use of naked flames is prohibited.

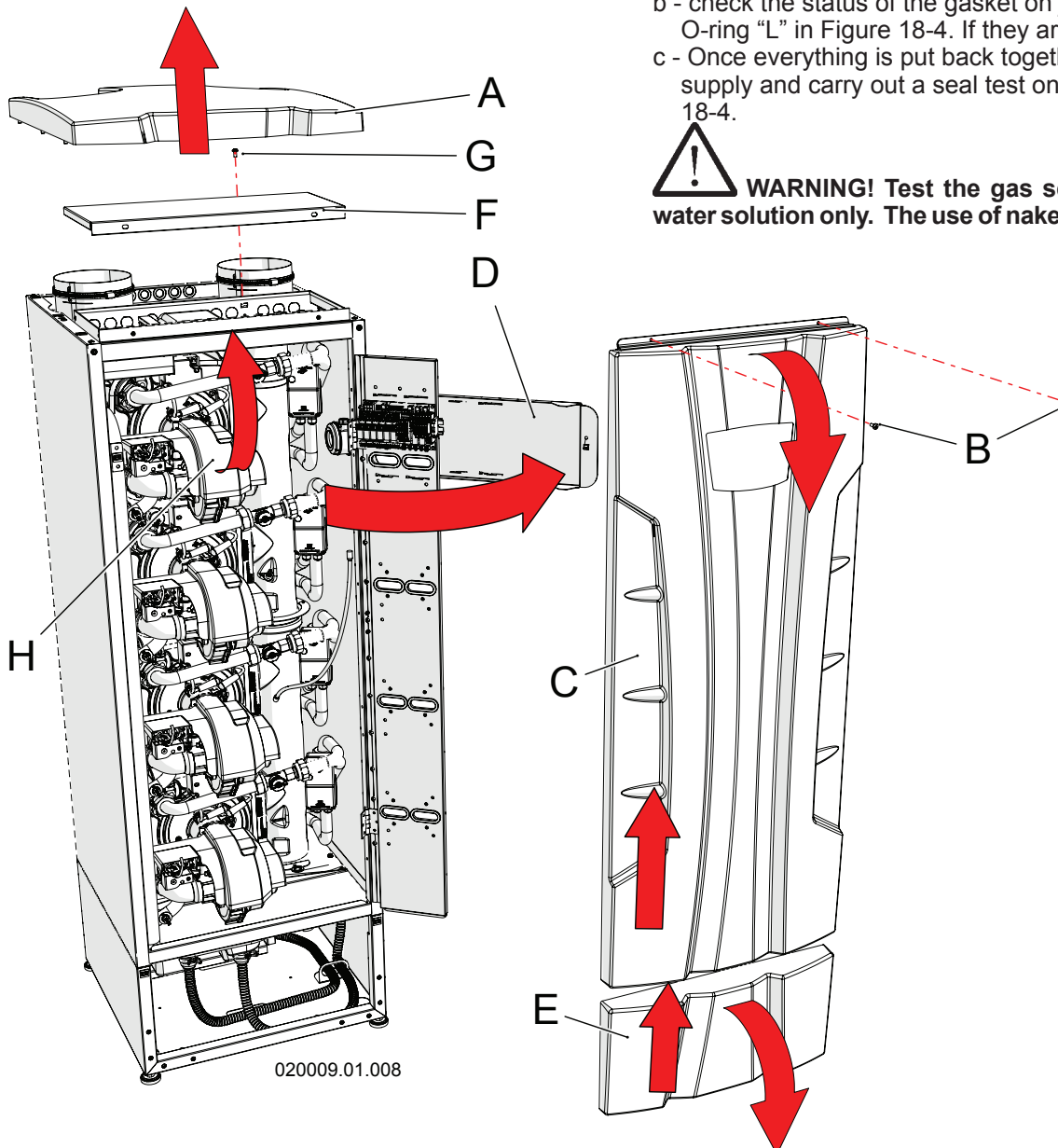

Figure 18-1 - Dismantling of casing and opening of control panel

18.4 - Cleaning the burner and the primary heat exchanger, flue gas side

For correct cleaning of the burner and the heat exchanger body (flue gas side), proceed as follows (refer to Figure 18-5 unless otherwise advised):

- 1.- access the boiler's internal parts by following the procedure described in section 18.2;
- 2.- dismantle the burner fan assembly by following section 18.3;
- 4.- Pass a cylindrical brush with nylon bristles into the combustion chamber "H"

 **WARNING! DO NOT use a metal brush. Only use a brush with bristles made of nylon or a similar material.**

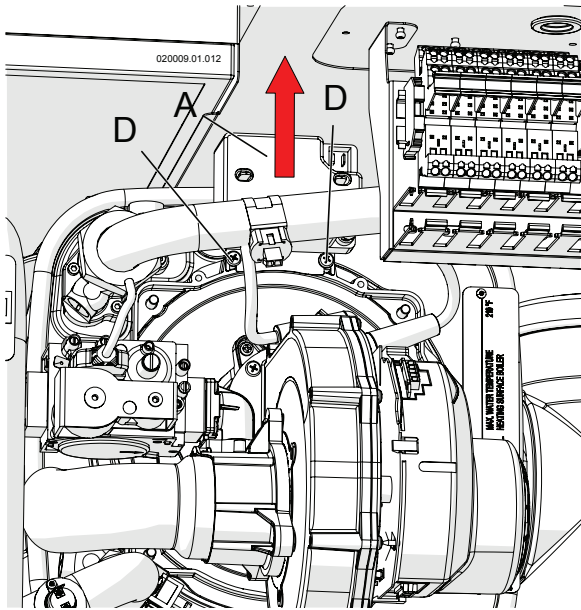

Figure 18-2 - Dismantling sparks generator

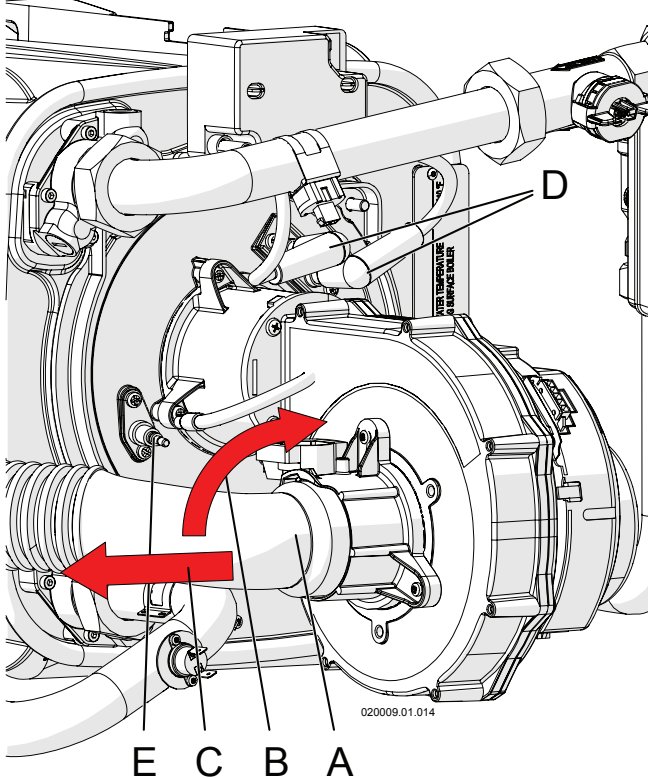



Figure 18-3 - Removing the air manifold

- 5.- using an extractor, suck up the unburnt residue found inside the combustion chamber "H";
- 6.- with the same extractor, clean the surface of the burner and around the electrodes;
- 7.- reassemble the parts in reverse order;
- 8.- turn on the gas cock;
- 9.- restore the electric power supply.
- 10.- check that there are no gas leaks between the joints that were removed;

 **WARNING! Test the gas seal using a soap and water solution only. The use of naked flames is prohibited.**

 **WARNING! Whenever the burner or primary heat exchanger is cleaned the good order of the heat insulation devices "R" and "S" must be checked (see figure 18-5). If necessary, replace them together with gasket "T" in the burner (see figure 18-5), requesting the relevant kit, code 62632006.**

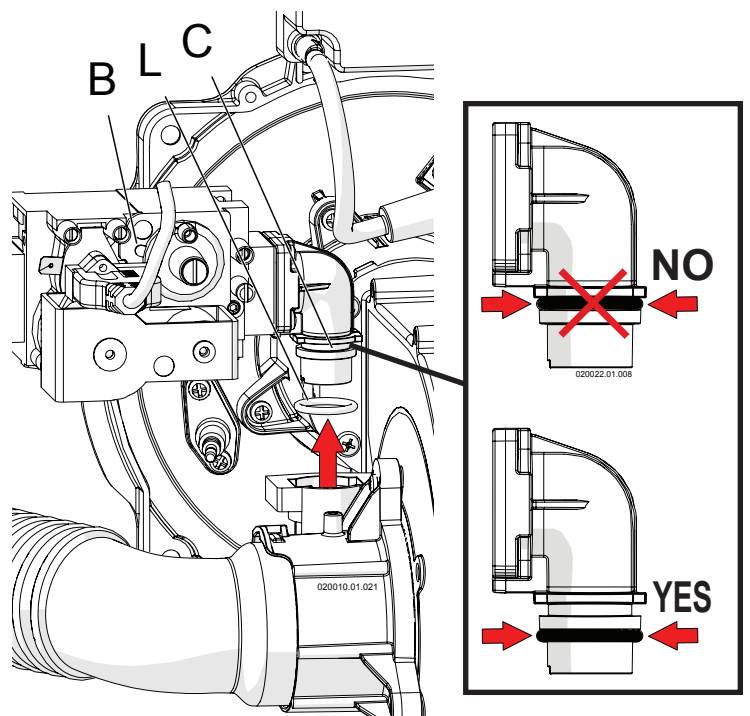
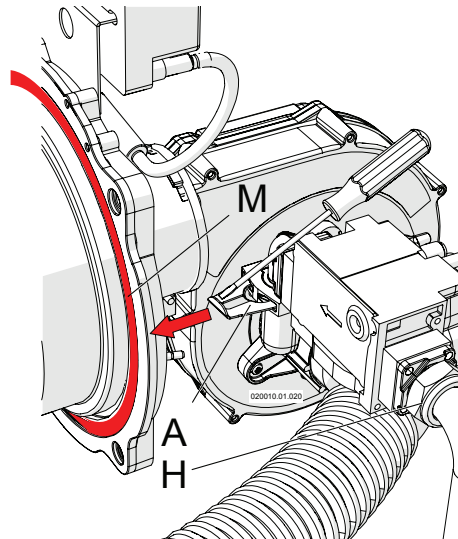

Figure 18-4 - Removing the gas valve

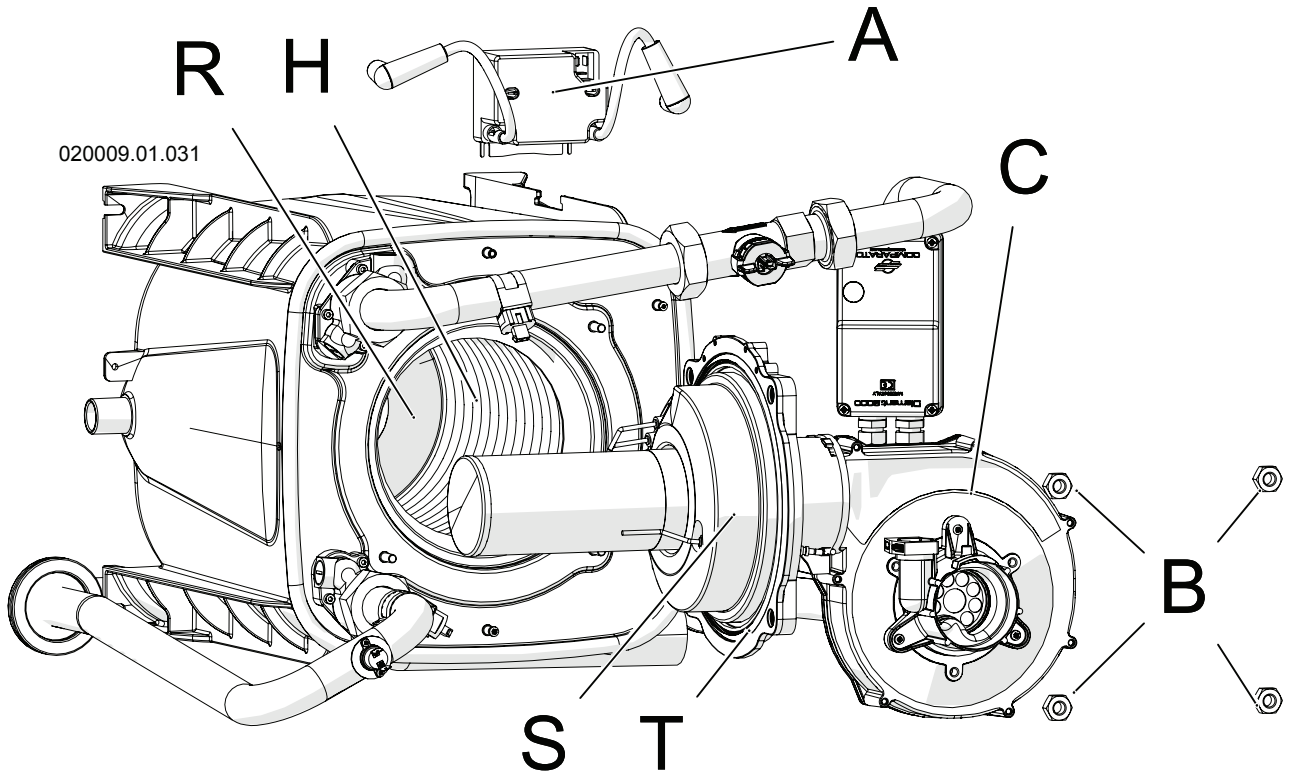
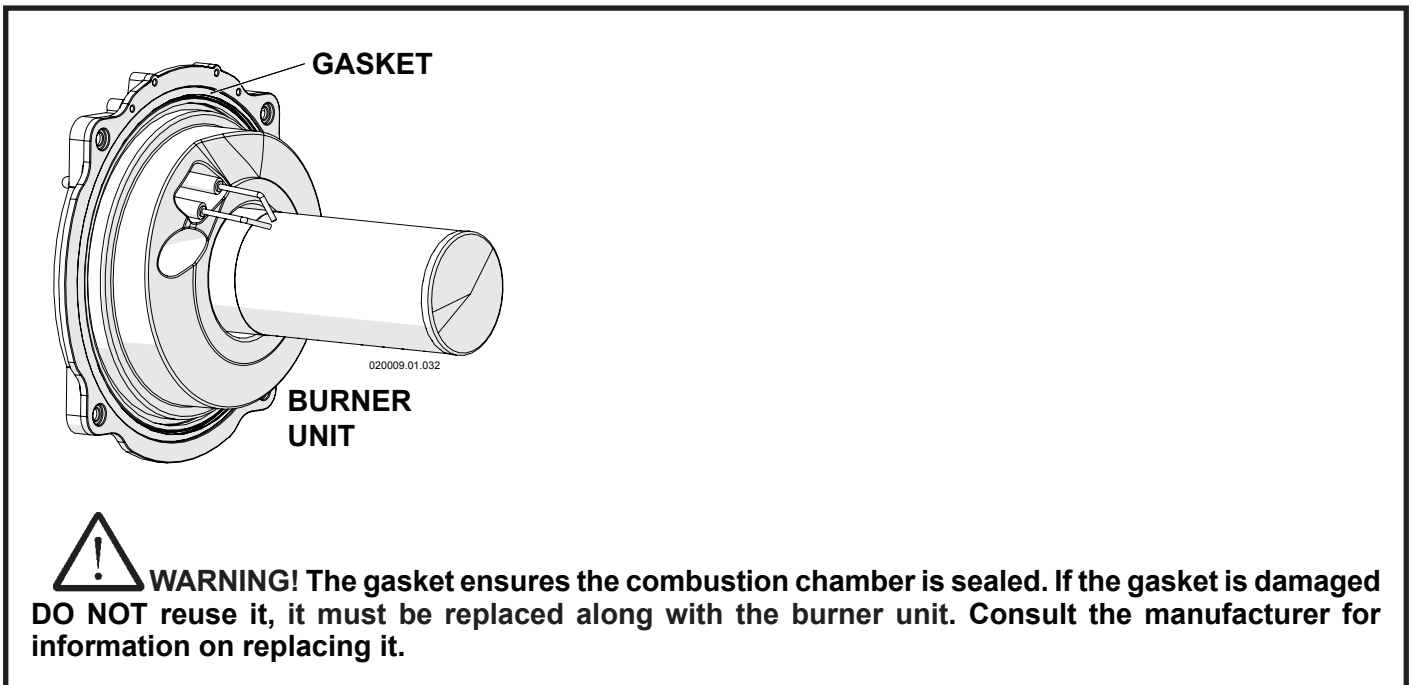

Figure 18-5 - Dismantling fan burner assembly



18 - MAINTENANCE

18.4.1 - Heat insulation devices

The heat insulation devices must be checked once a year and replaced if broken or damaged. See figure 18-6 in which the heat insulation devices (details "C" and "E") are shown disassembled from the heat exchanger and burner. To replace them, refer to the instructions provided with the spare part.

- A = Fixing screw
- B = Washer
- C = Heat insulation device
- E = Heat insulation device
- E = White heat insulation device
- G = Burner
- H = Gasket
- L = Ignition electrodes
- M = Screws
- N = Detection electrode
- Q = White heat insulation device
- R = Gasket
- S = Gasket

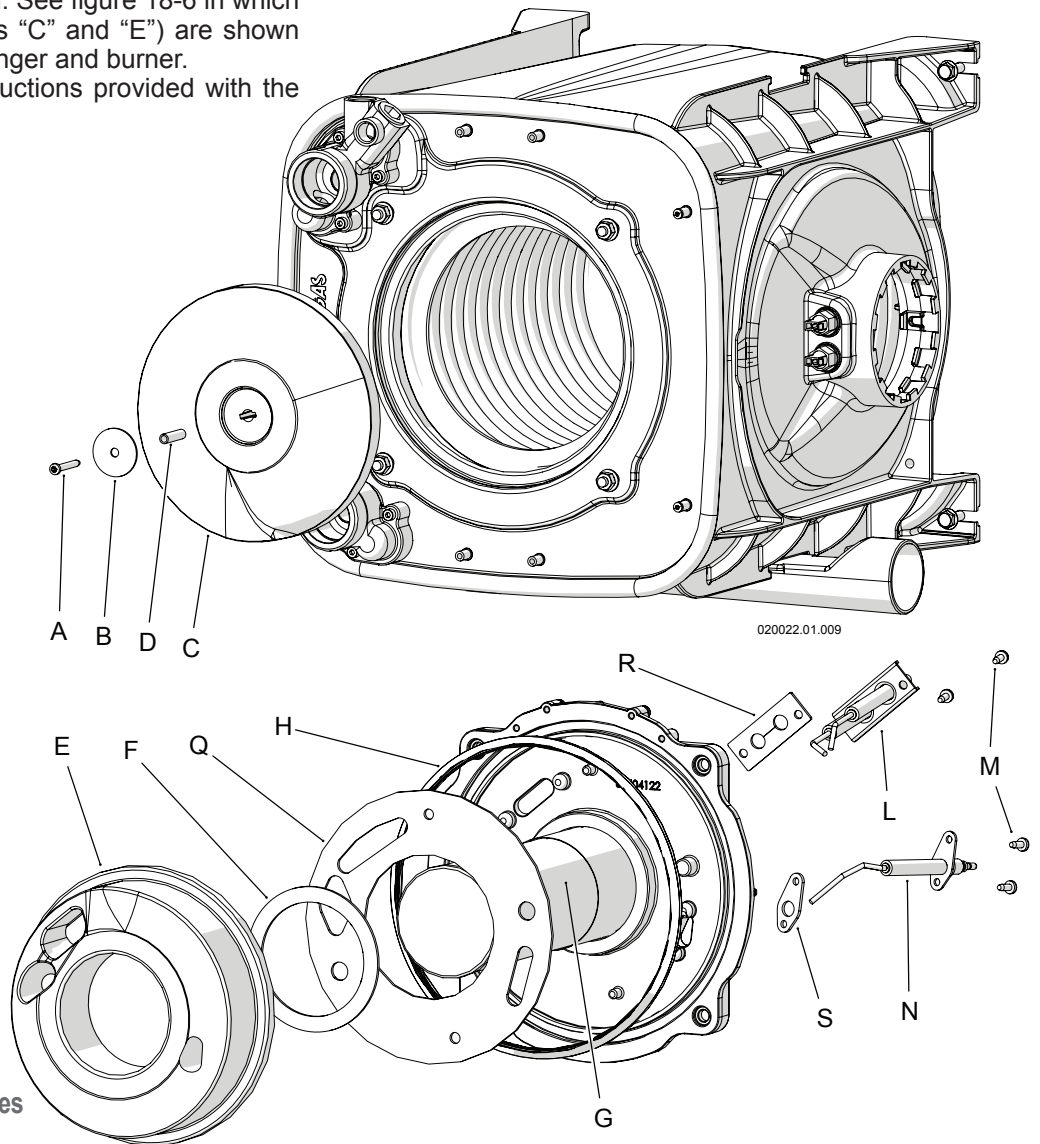
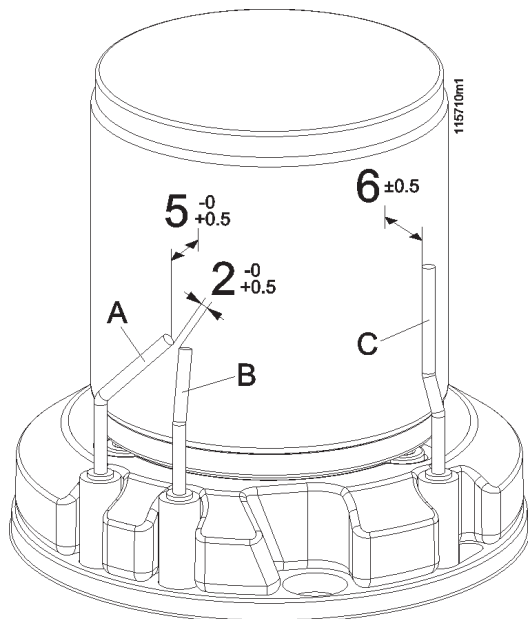

Figure 18-6 - Heat insulation devices



- A = Left-hand ignition electrode
- B = Right-hand ignition electrode
- C = Detection electrode

Figure 18-7 - Position of electrodes on the burner

18.5 - Correct positioning of ignition and ionisation electrodes

For the appliance to work well, the electrodes must be positioned correctly (refer to figure 18-7):

- the distance between ignition electrodes "A" and "B" must be between 2.0 and 2.5 mm;
- the distance of ignition electrodes "A" and "B" from the surface of the burner must be between 5 and 5.5 mm;
- the distance of ionisation electrode "C" from the surface of the burner must be between 5.5 and 6.5 mm.

For accurate location of the electrodes it is good to use sliding callipers to respect the tolerances given in Figure 18-7.

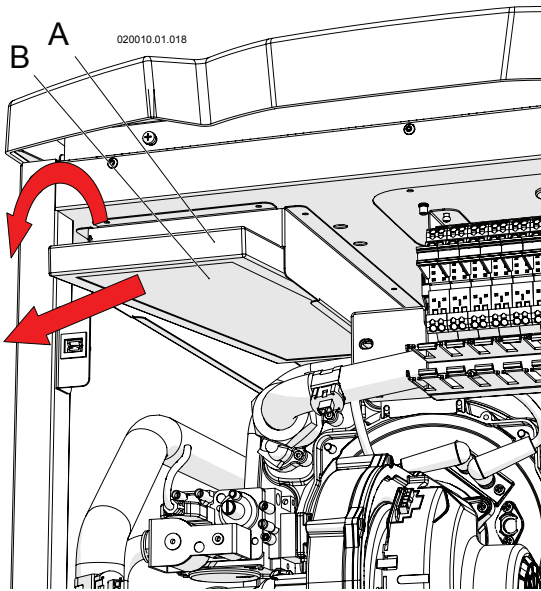

Figure 18-8 - Dismantling air intake filter

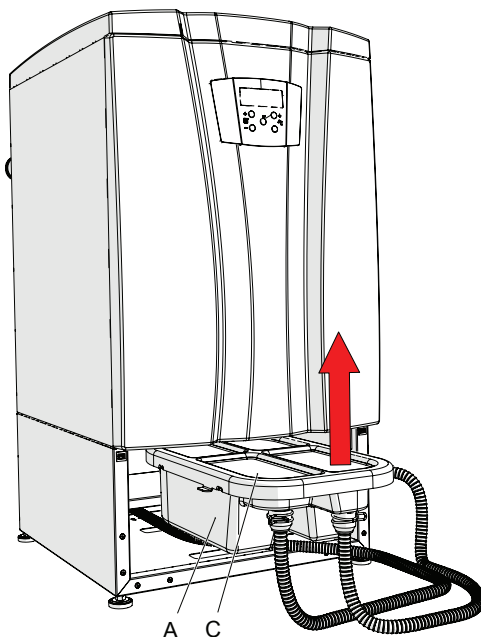
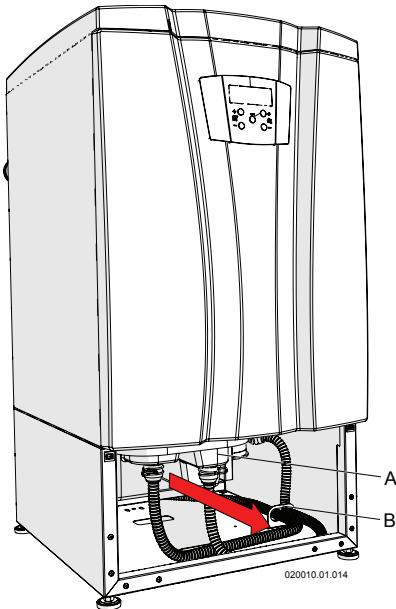

Figure 18-9 - Dismantling and opening condensate neutraliser box

18.6 - Cleaning of air intake filter

The air filter must be cleaned in order for the boiler to work correctly. Refer to figure 18-8 and proceed as follows:

1. - access the boiler's internal parts by following the procedure described in section 18.2;
2. - pull out filter detail "A" as shown in the figure;
- 3.- clean the filter with compressed air until its surface is clean again;
- 4.- reassemble the filter and the boiler's casing.

18.7 - Maintenance and cleaning of condensate outlet system

During boiler maintenance the condensate outlet pipe (detail "5" in figures 3-3, 3-5 and 3-7) is taken apart and cleaned of any residues. Refit the cleaned pipe and **restore the level of liquid in the siphon as shown in section 16.1.2.**

Check the level of pH every three months for the first year. Special litmus papers or a special electronic instrument that gives a more precise reading can be used to carry out the test (access the box via stopper "E" in figure 12-1). The frequency of these checks can then be reduced to every six months or year depending on how they are controlled by the local regulations in force. The neutralising contents of the box must be replaced when the level of pH falls below the level required by the regulations in force. The permitted acidity level goes from pH 5.5 to 9.5.

To replace the neutralising agent, do the following:

1. Follow the steps of section 18.2 to take off cover "E" in figure 18-1;
2. Remove box "A" (Figure 18-9);



WARNING! When the box is taken out, be careful to hold it at an angle so as to prevent any leaks of liquid that might cause damage.

3. Open cover "C" (Figure 18-9) upwards;
4. Check the good order of the box;
5. Check the good order of the neutralising material and if necessary add some or replace it;
6. Fill with fresh water until the water begins to flow out of the outlet;
7. Replace the box in the correct position;



WARNING! The neutralisation box is filled with water to prevent exhaust gas from escaping while the unit is in operation.

8. Turn on the gas supply;
9. Restore the boiler's electric power supply;



WARNING! Carefully follow figure 18-9 to replace the box "A" in the correct position. **After the maintenance described above, restore the level of liquid in the siphon as shown in section 16.1.2.**

18.8 - Connection of Display to other burners

In boilers from 140T to 280T, which are multi-burner, the display shown in figure 17-1, is always directly connected to "Burner 1 (Master)". All the parameters that can be consulted on the display (sections 17.14, 17.15 and 20), that refer to Burner 1 (Master) exclusively concern that burner. If you want to see/change the same parameters for the other burners, you must move the connection of the display from "Burner 1 (Master)" to the burner to be displayed/changed; proceed as follows: (refer to Figure 18-10):

1. Disconnect the electric power supply from the boiler;
2. Follow the steps of section 18.2 to access the internal components;
3. Disconnect terminal "B" (coming from the display) from terminal "A" (coming from "Burner 1 (Master)");
4. Connect terminal "B" to terminal "C", "D", or "E" depending on which burner you want to examine or change, considering this: terminal "C" is for "Burner 2"; terminal "D" is for "Burner 3" and terminal "E" is for "Burner 4"
5. Once the terminal is connected to the one to be checked, restore voltage to the boiler and turn it on;
6. Now the display shows all the information relating to the burner connected. Make any consultation or change following the steps in sections 17.14, 17.15 and 20.
7. Once the check is completed, reconnect connector "B" to connector "A" as it was before.

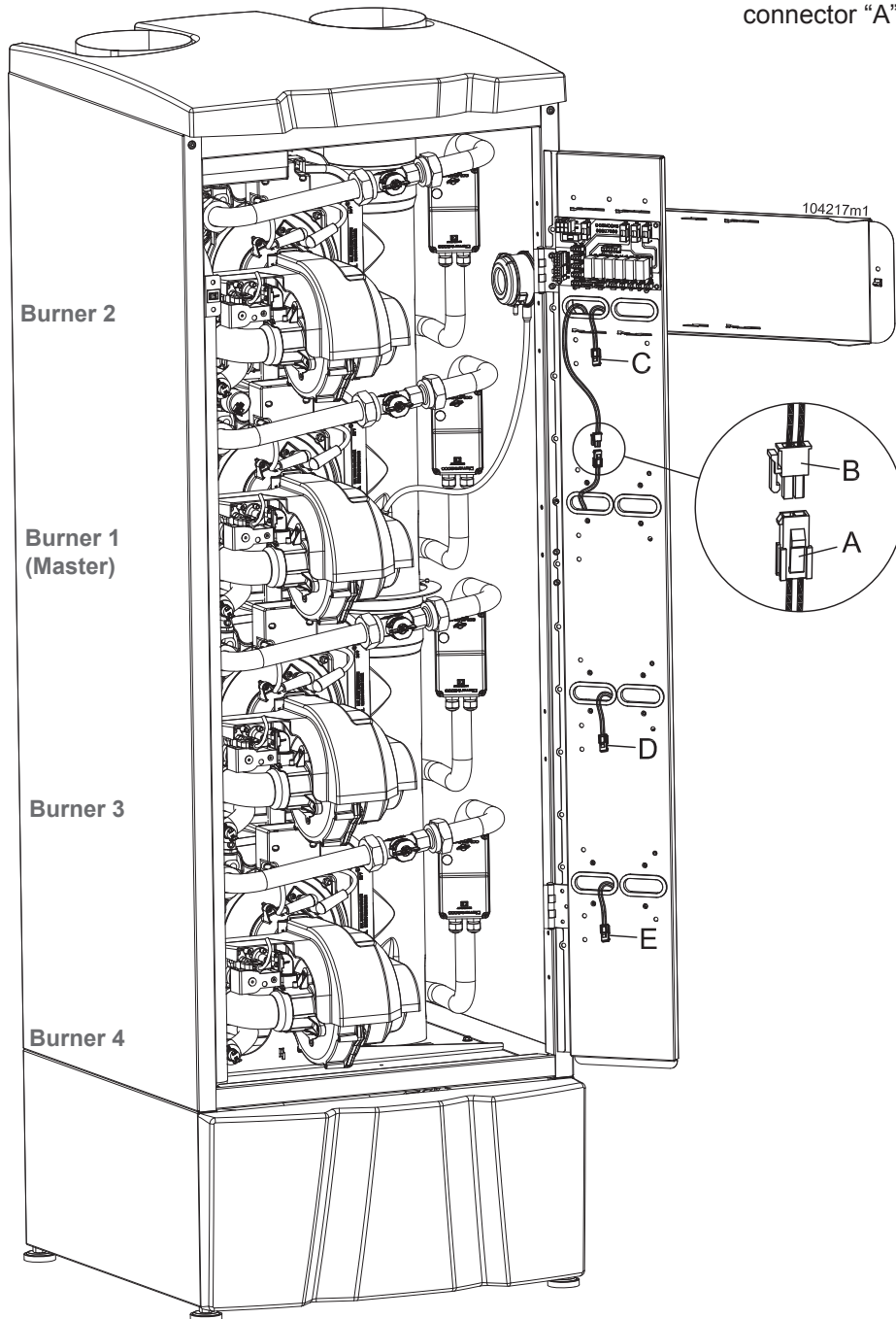

- A = Connector for dialogue Burner 1 (Master)
- B = Connector from display
- C = Connector for dialogue Burner 2
- D = Connector for dialogue Burner 3 (Only in models 210T and 280T)
- E = Connector for dialogue Burner 4 (Only in model 280T)

Figure 18-10 Connection of display in other burners

18.9 - How to move a control board

Boiler models from 140T to 280T are set up to be managed by a control board (Burner 1 Master). All the devices are connected to this board: room thermostat, external sensor, pump commands, external safety devices, and all internal safety devices: condensate level sensor, exhaust gases differential pressure switch, etc.

If the Burner 1 control board has an error, the boiler stops working. If the technician does not have the parts to replace the board, he can temporarily replace it with the board from one of the other burners present on the boiler, in order to restart it. To do this, proceed as follows:

(refer to Figure 18-10 unless advised otherwise)

1. Turn off the general switch and disconnect the electric power supply;
2. Follow the steps of section 18.2 to access the internal components;
3. Disconnect connector "B" (the connector that comes from the display) from connector "A" (the connector that comes from "Burner 1 (Master)");
4. Disconnect all the other connectors from Burner 1 (Master)'s control board;
5. Remove the control board of Burner 1 (Master) from the boiler;
6. Follow points 3 to 5 to remove the control board from the burner located lowest down;
7. Fit the board in place of that of Burner 1 (Master);

8. Restore all the connections to the new Burner 1 (Master) board;
9. Move selector switch "S4" as shown in figure 18-11, from the OFF position to the new ON position;
10. Take great care with the connectors of the board that's been removed. They must be isolated to avoid short circuits and damage;
11. Isolate each of these connections electrically;
12. Replace the boiler casing;
13. Reconnect the electric power supply and turn on the boiler's general switch;
14. Access the forced menu, follow the steps of section 20 and set all the parameters as shown in the "Burner 1 (Master)" column. Parameter **3050** must be reduced by one unit compared to the previous status, because the boiler now has one Slave Burner fewer;
15. Interrupt the electric power supply;
16. Reconnect the boiler's electric power supply. Now Burner 1's new control board is controlling the boiler.

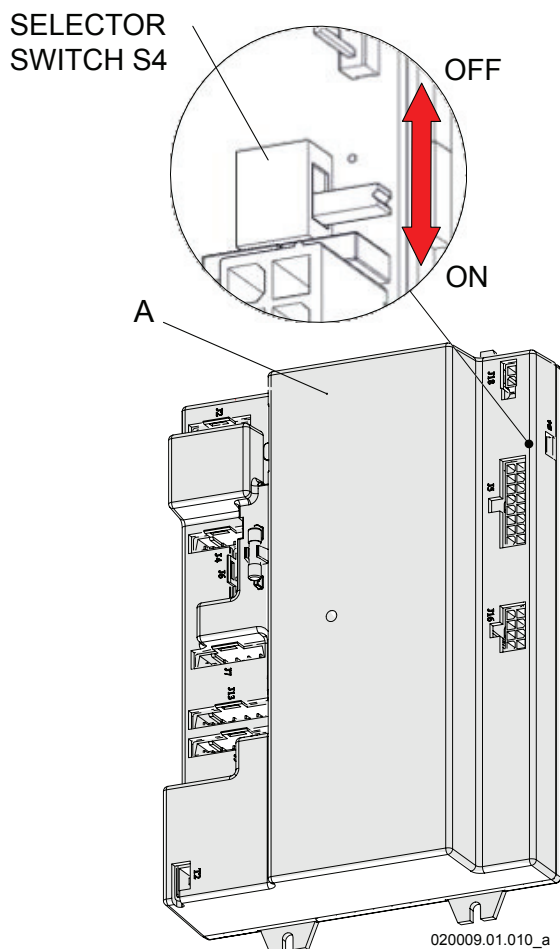

Figure 18-11 - Command board

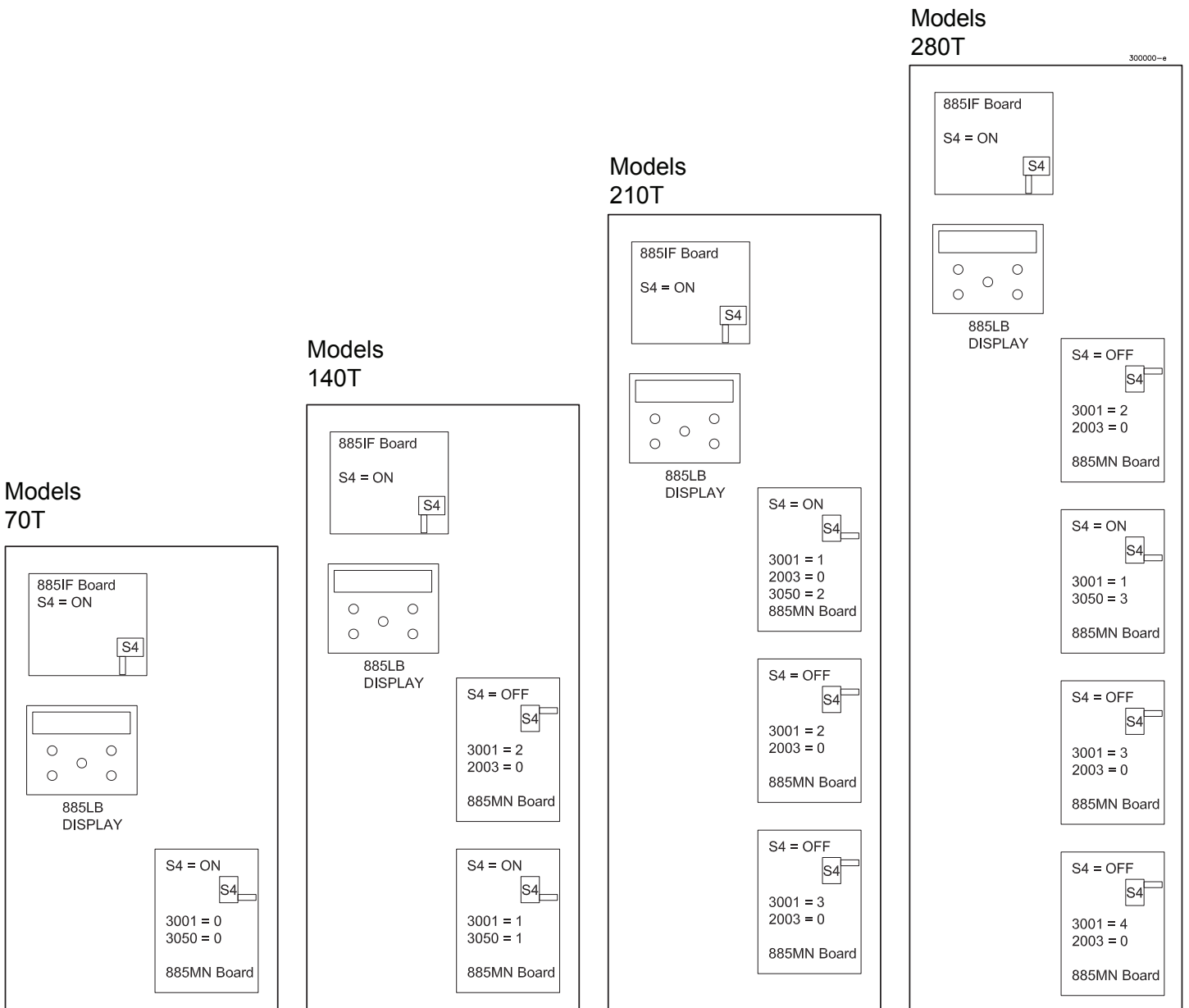

Figure 18-12 Setting parameters 3001, 3050 and selectors S4

18.10 - Emptying the boiler

- 1.- generate a request for heat by increasing the domestic hot water and central heating temperature (in the MYDENS version, if necessary also close the room thermostat link);
- 2.- wait for the burner to come on (in multi-burner versions wait for all the burners to come on (see corresponding icons "L" in figure 17-1 which all come on when all burners are on);
- 3.- switch the appliance off. In this way any motorised valves present stay on);
- 4.- close the system fill cock provided by the installer;
- 5.- connect a flexible rubber hose to the drain valves "38" in Figures 3-3, 3-5 and 3-7 and use it for draining into a sink drain or similar;
- 6.- wait for the water inside the boiler to cool to below approx. 40°C;
- 7.- slowly open the drain valves;
- 8.- Open the air vent valves of the heating elements. Start from the highest central heating elements and continue with the lowest.
- 9.- Once all of the water has been evacuated, close all of the heating element vent valves and drain cocks.



WARNING! Do not salvage and/or reuse the water evacuated from the central heating circuit for any purpose as it could be polluted.

18.11 - Minimum and maximum power

Operation can be forced at minimum maximum or ignition power, proceed as follows:

- 1.- make sure that the heat generated by the boiler can be dispersed by the system;



WARNING! When forcing the delivery temperature, it automatically sets itself at 93°C to dispose of as much of the heat generated by the boiler as possible. Check whether the system can support this temperature.

- 2.- access parameter **20 10** (**2200** for multi-burner models) located in the "installer menu" (see section 17.15);
- 3.- set the parameter at the following value:
 - a) **L 0**. to force the burner, or all the burners, at minimum power;
 - b) **197** to force the burner, or all the burners, at ignition power;
 - c) **H 197** to force the burner, or all the burners, at maximum power;
- 4.- To end forcing, return parameter **20 10** (**2200** for multi-burner models) to the **OFF** value and press the RESET button.



WARNING! If during forcing, the power supplied by the boiler is much higher than the power absorbed by the system, the boiler switches off continuously to reach the maximum temperature allowed (93°C).

The same procedure as above can also be applied to multi-burner boilers models from 100T to 280T but it must be borne in mind that only one burner can be forced at a time, moving the display from one burner to another, as described in section 18.8.

18.12 - Checking the ionisation current

In any state of operation, even during minimum and maximum power checks as described in section 18.11, it is possible to consult the value of the ionisation current on parameter

1000 that appears in the "user menu" (section 17.14). This value must be between 4 and 7 uA (microampere).

Since parameter **1000**, on multi-burner boilers (models from 100T to 280T) relates to Burner 1 (Master), you must refer to section 18.8 to do the check on the other burners.

18.13 - Checking combustion efficiency

According to national laws on gas appliances, it is necessary to periodically check the combustion efficiency;

To do this, operate exactly as stated in section 16.8 and check, along with the power, the combustion efficiency, which must be over the regulatory requirements.

18 - MAINTENANCE

18.14 - Water temperature measurement sensors

Various temperature sensors are positioned on the heat exchanger body. The electrical resistance between the two sensor contacts must correspond to figure 18-13.

The temperature sensors are: 1001, 1002, 1006 and 1007

18.15 - Outdoor temperature sensor

The outdoor temperature sensor 1004 (see section 13.1.4) is fitted as standard. The electrical resistance between the two sensor contacts must correspond to that shown in figure 18-14.

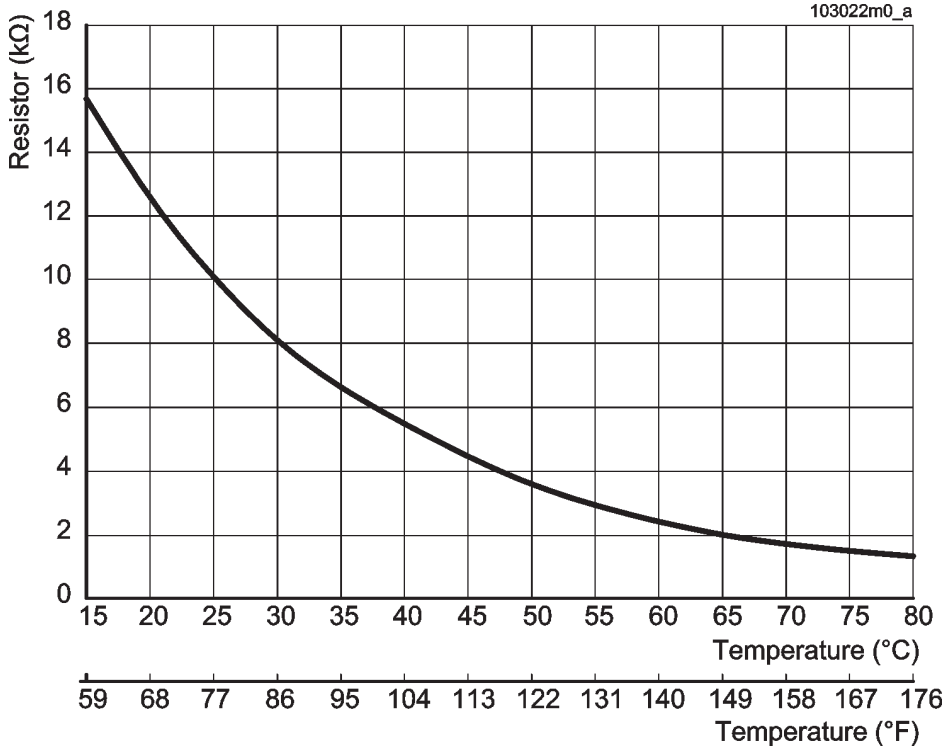

Figure 18-13 - Water sensors curve

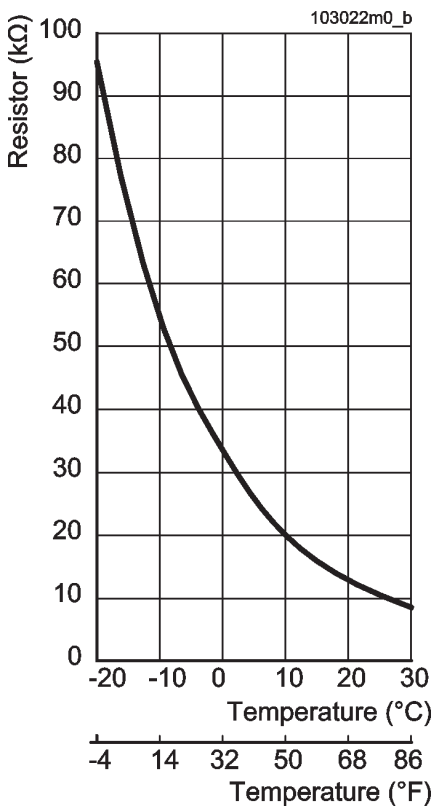

Figure 18-14 - Outdoor temperature sensor curve

18.16 - Multi-wire wiring diagram for models 70T

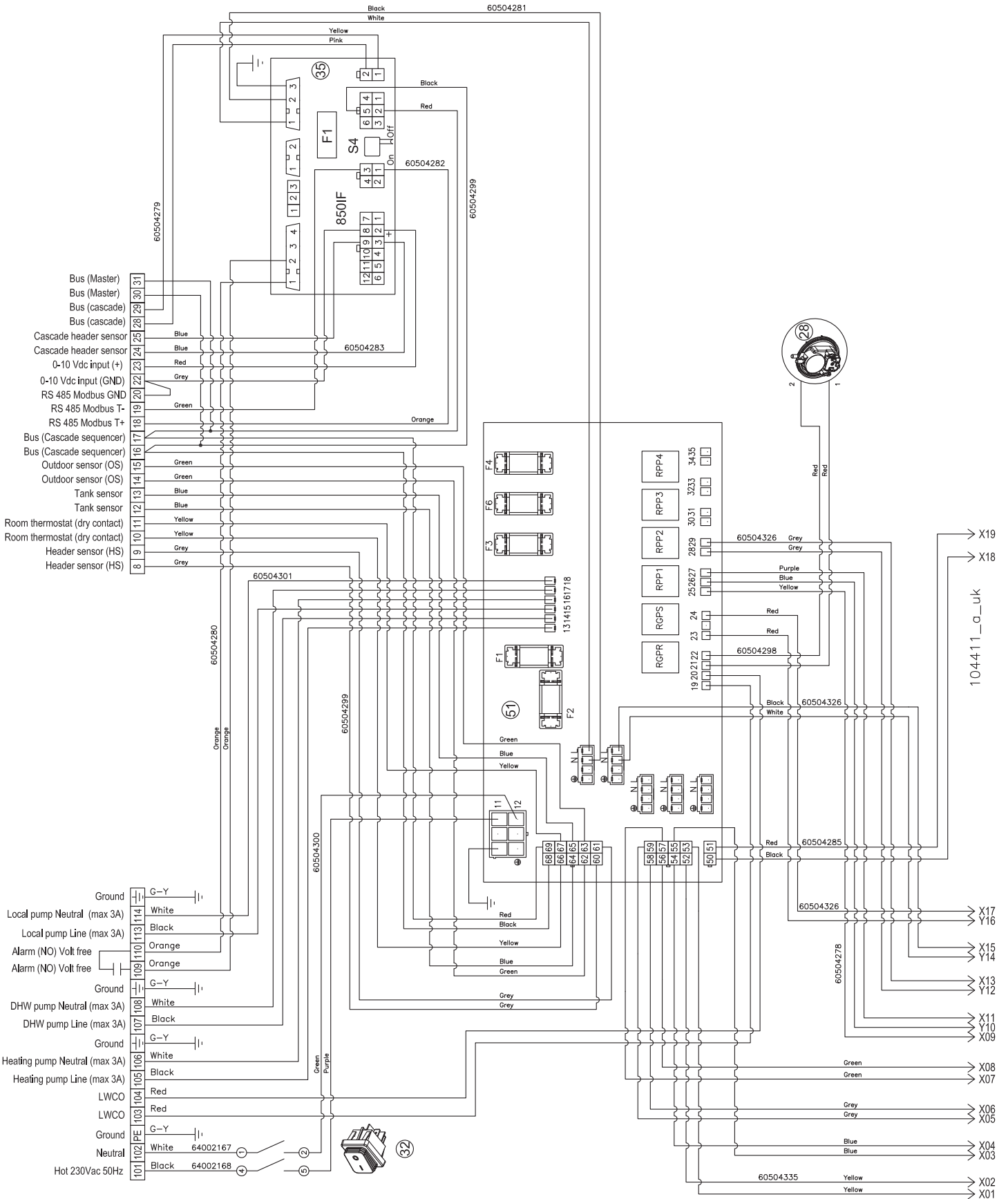

Figure 18-15 - Multi-wire wiring diagram part 1 - continues on next page

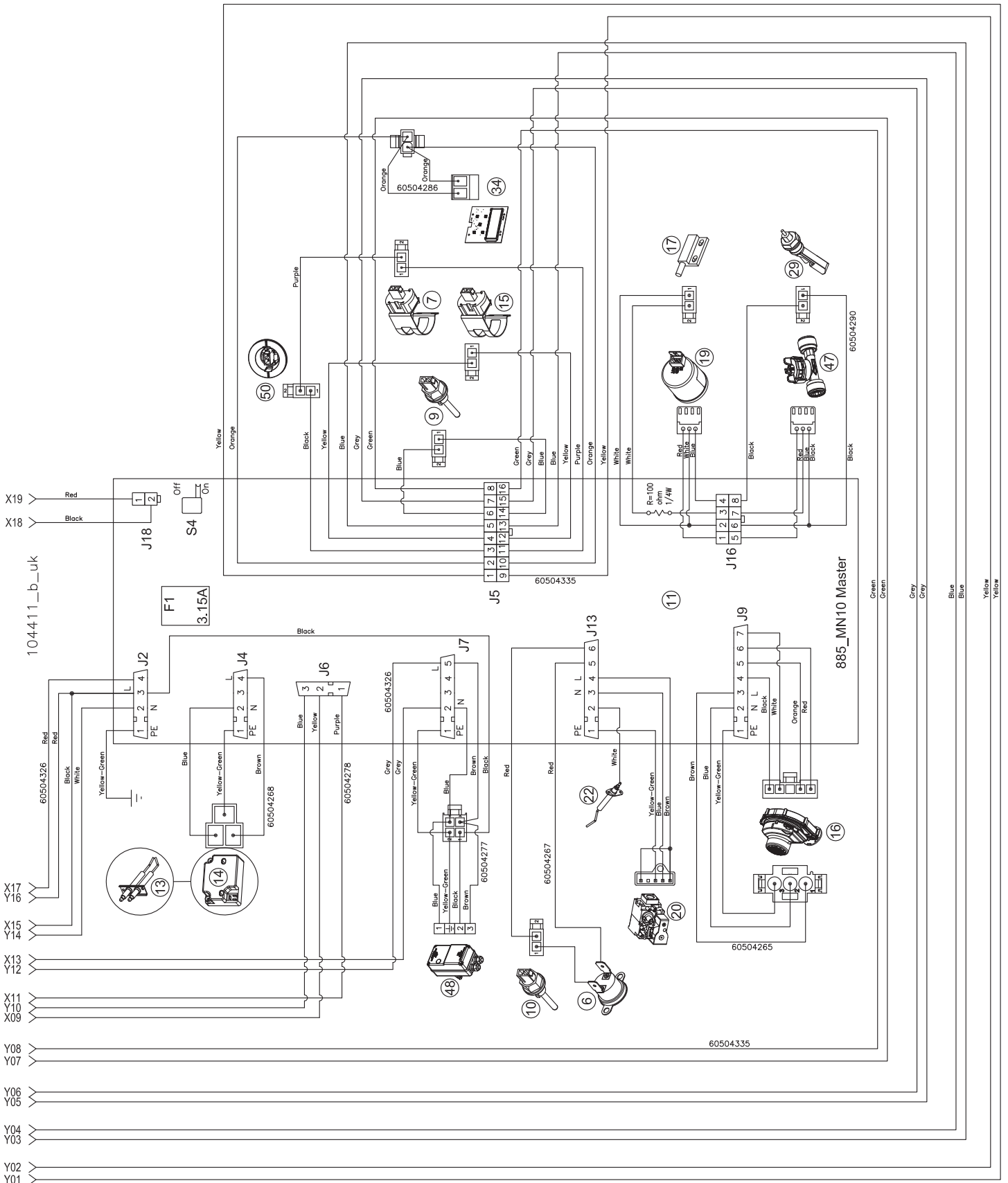

Figure 18-15 - Multi-wire wiring diagram part 2 - continued from previous page

18.17 - Multi-wire wiring diagram for models 140T, 210T and 280T

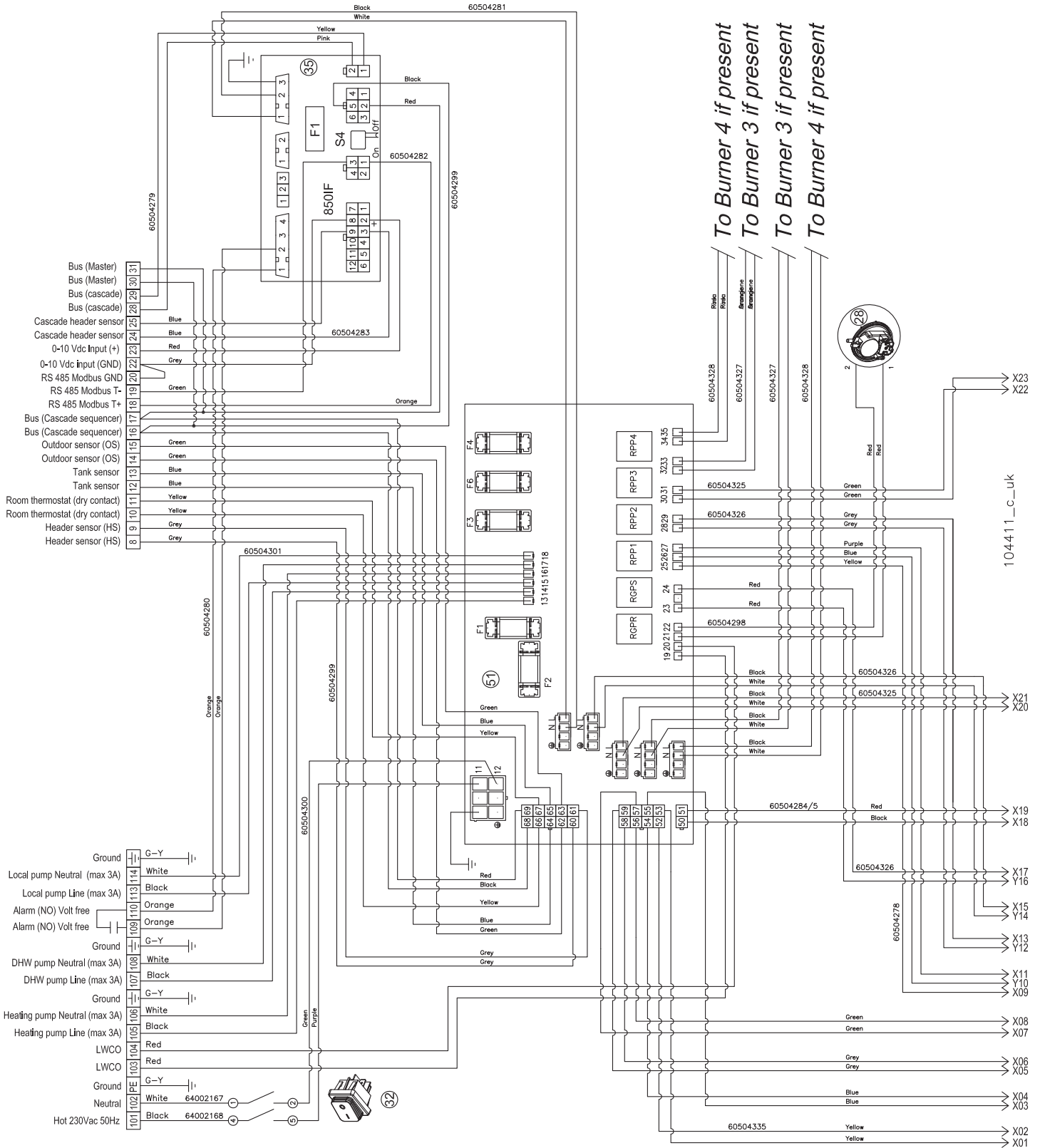
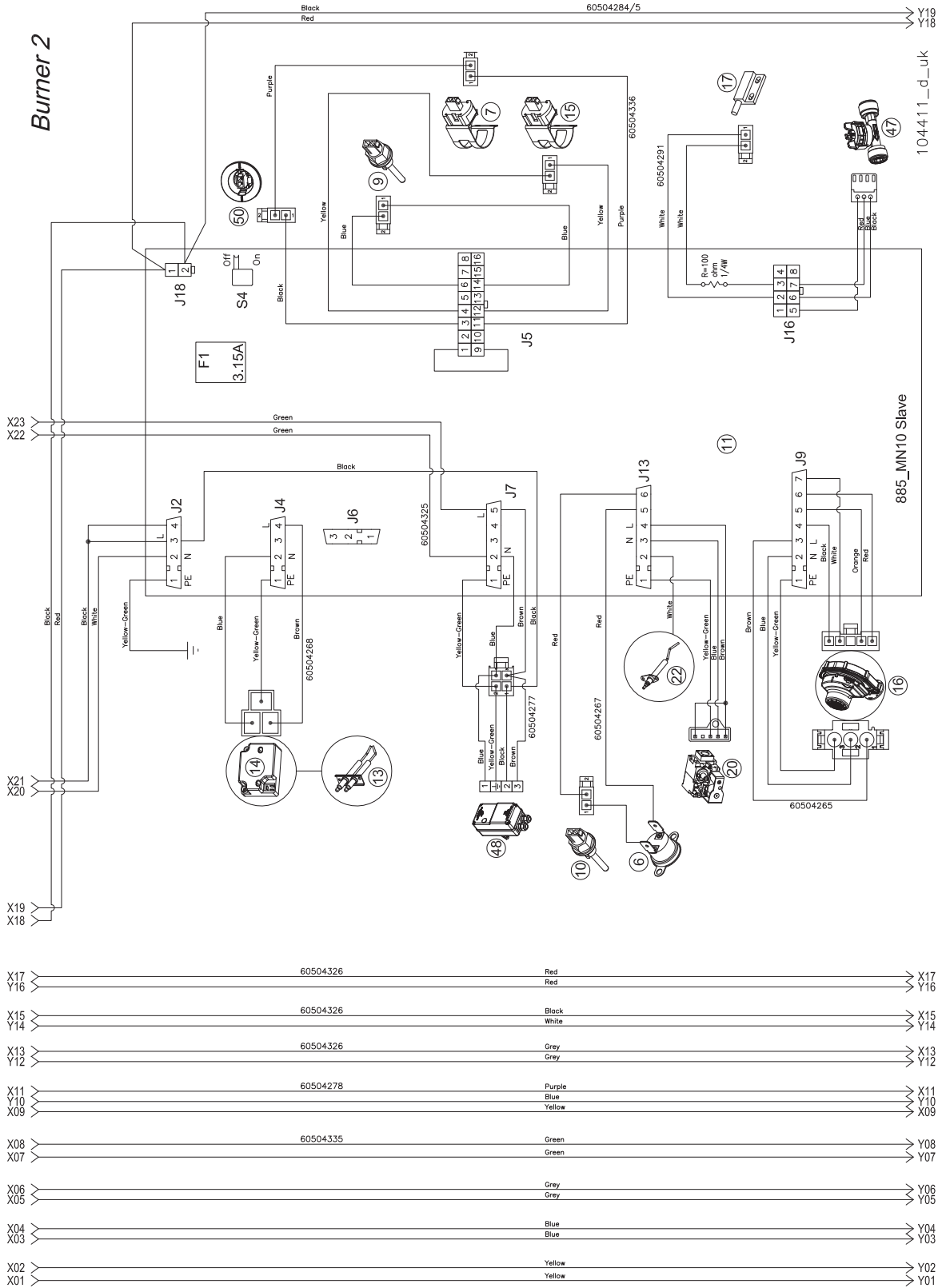

Figure 18-16 - Multi-wire wiring diagram part 1 - continues on next page



Continues

Figure 18-16 - Multi-wire wiring diagram part 2 - continues on next page

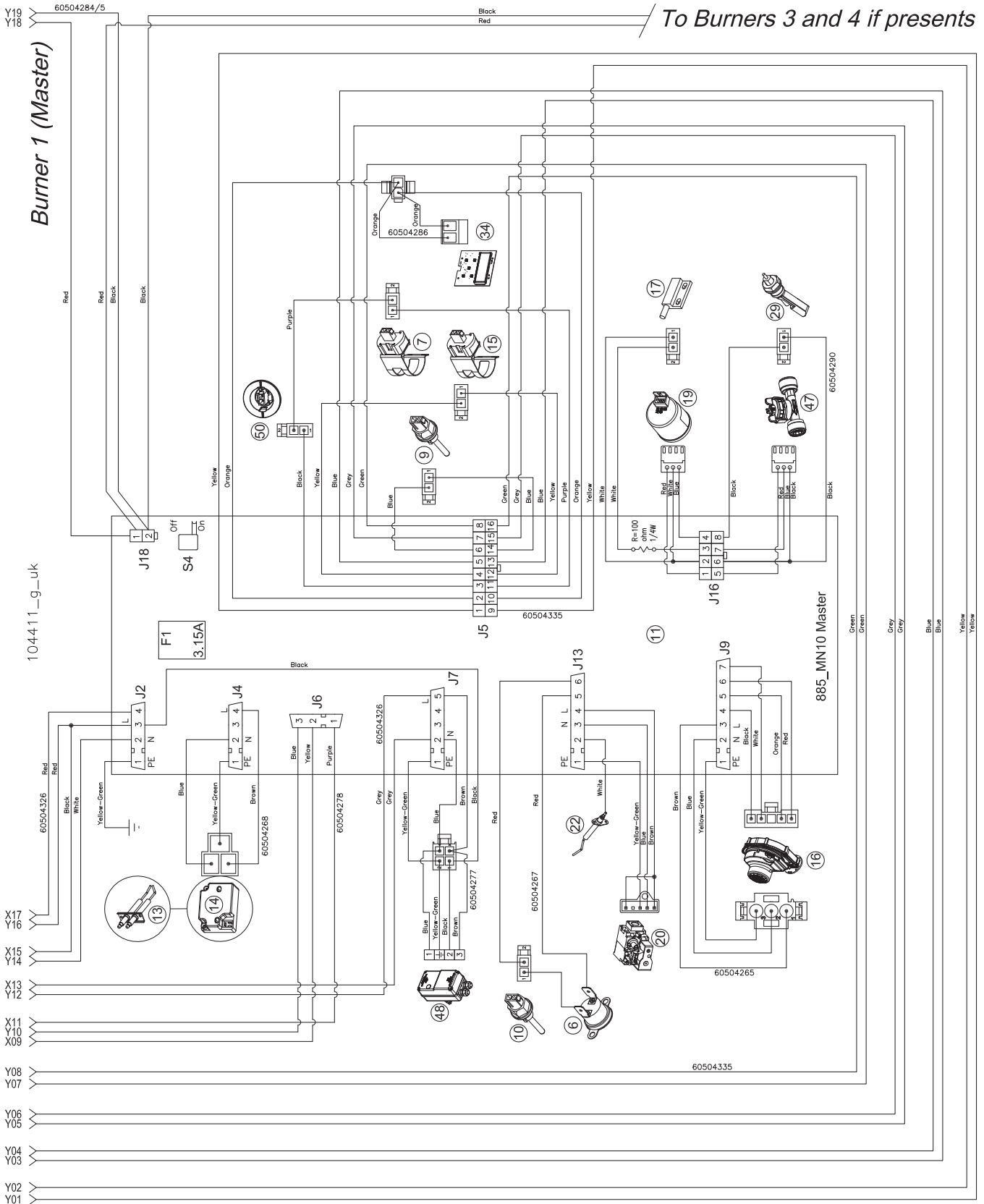

Figure 18-16 - Multi-wire wiring diagram part 3 - continued from previous page

18 - MAINTENANCE

Key to wiring diagrams figures 18-15 and 18-16

- 6 - Water outlet safety thermostat
- 7 - Water outlet temperature sensor
- 9 - Exhaust gases temperature sensor
- 10 - Exhaust gases temperature safety fuse
- 11 - Command and control board
 - Fuse - F1 5x20 3A
- 13 - Ignition electrodes
- 14 - Sparks generator
- 15 - Water inlet temperature sensor
- 16 - PWM modulating fan
- 17 - Back flue preventer valve (flapper valve)
- 19 - Water pressure gauge
- 20 - Gas valve
- 22 - Detection electrode
- 28 - Exhaust gases differential pressure switch
- 29 - Condensate level sensor
- 32 - General ON/OFF switch
- 34 - Display
- 35 - Board 885 IF (on request)
 - Fuse - F1 5x20 3A
- 47 - Water flow rate sensor
- 48 - 2-way motorised valve (on request)
- 50 - Primary heat exchanger temperature fuse
- 51 - Electrical connections board
 - Fuse - F1 5x20 10A
 - Fuse - F2 5x20 10A
 - Fuse - F3 5x20 3A
 - Fuse - F4 5x20 3A
 - Fuse - F6 5x20 3A
- RGPR - Heating circuit pump relay
- RGPS - Domestic hot water circuit pump relay
- RPP1 - Primary circuit pump relay burner 1 (MASTER)
- RPP2 - Primary circuit pump relay burner 2
- RPP3 - Primary circuit pump relay burner 3
- RPP4 - Primary circuit pump relay burner 4

19 - TECHNICAL DATA

19.1 - MYDENS TECHNICAL DATA

MYDENS TECHNICAL DATA		UM	70T
Type (Type of flue gas exhaust/air intake)			B23 ; B3P
Category			I12H3P
EU type approval certificate (PIN)			0476CR1272
Range Rated Boiler			APPROVED
Central heating max. heat input "Qn" PCI (PCS)		kW	69.9 (77.6)
Central heating min. heat input PCI (PCS)		kW	14.7 (16.3)
Central heating max. useful output power (80/60) "Pn"		kW	67.8
Efficiency at 100% load (80/60) PCI (PCS)		%	97.0 (87.4)
Min. useful output power (80/60)		kW	14.1
Efficiency at min. useful output power (80/60)		%	96.2 (86.7)
Central heating max. useful output power (50/30)		kW	73.5
Efficiency at central heating max. useful output power (50/30) PCI (PCS)		%	105.1 (94.7)
Min. useful output power (50/30)		kW	15.6
Efficiency at min. useful output power (50/30) PCI (PCS)		%	106.3 (95.8)
Efficiency at 30% of the load PCI (PCS)		%	106.4 (95.9)
Losses at the chimney, burner ON (80/60)		%	1
Losses at the chimney, burner OFF		%	0.1
Losses at the casing, burner OFF		%	0.1
Losses at the casing, burner OFF		%	0.05
Gas flow rate	G20	m ³ /h	7.39
	G25	m ³ /h	8.60
	G30	kg/h	5.51
	G31	kg/h	5.43
Gas supply pressure	G20	mbar	20
	G25	mbar	25
	G30	mbar	30
	G31	mbar	37
Gas supply minimum pressure	G20	mbar	17
	G25	mbar	20
	G30	mbar	25
	G31	mbar	25
Gas supply maximum pressure	G20	mbar	25
	G25	mbar	30
	G30	mbar	35
	G31	mbar	45
Primary heat exchanger water content		l	5.7
Minimum operating water flow rate with motorised valves		l/h	/
Minimum operating water flow rate without motorised valves		l/h	2700
DHW adjustment range with storage tank		°C	40 - 60
Maximum temperature for safety intervention		°C	95
Maximum central heating temperature		°C	80
Minimum central heating temperature		°C	20
Maximum central heating pressure "PMS"		bar	11
Minimum central heating pressure		bar	1
Rated power supply voltage		V	230
Rated power supply frequency		Hz	50
Absorbed electrical power		W	150
Electrical protection rating			IP20

19 - TECHNICAL DATA

19.1 - MYDENS TECHNICAL DATA

140T	210T	280T
B23 ; B3P		
I12H3P	I12H3P	I12H3P
0476CR1272	0476CR1272	0476CR1272
APPROVED	APPROVED	APPROVED
140.0 (155.4)	210.0 (233.1)	280.0 (310.8)
14.7 (16.3)	14.7 (16.3)	14.7 (16.3)
135.8	203.7	271.6
97.0 (87.4)	97.0 (87.4)	97.0 (87.4)
14.1	14.1	14.1
96.2 (86.7)	96.2 (86.7)	96.2 (86.7)
147.1	220.7	294.3
105.1 (94.7)	105.1 (94.7)	105.1 (94.7)
15.6	15.6	15.6
106.3 (95.8)	106.3 (95.8)	106.3 (95.8)
106.4 (95.9)	106.4 (95.9)	106.4 (95.9)
1	1	1
0.1	0.1	0.1
0.1	0.1	0.1
0.05	0.05	0.05
14.80	22.20	29.61
17.22	25.83	34.43
11.03	16.55	22.06
10.87	16.30	21.73
20	20	20
25	25	25
30	30	30
37	37	37
17	17	17
20	20	20
25	25	25
25	25	25
25	25	25
30	30	30
35	35	35
45	45	45
11.4	17.1	22.8
2700	2700	2700
5400	10800	10800
40 - 60	40 - 60	40 - 60
95	95	95
80	80	80
20	20	20
11	11	11
1	1	1
230	230	230
50	50	50
300	430	590
IP20	IP20	IP20

19 - TECHNICAL DATA

19.1 - MYDENS TECHNICAL DATA

MYDENS TECHNICAL DATA		UM	70T
Burner electrical power		W	150
Air intake and flue gas exhaust pipe diameter (split)		mm	110
Max. length of flue gas outlet duct (split)		m	10
Air intake pipe max. length (split)		m	10
Equivalent length of a bend		m	4
Weighted CO (0% O ₂)	G20	ppm	27
Weighted NO _x (0% O ₂) (Class 6 EN 15502) PCS	G20	mg/kWh	34
CO ₂ (%) at minimum/maximum power	G20	%	8.5 / 8.7
	G25	%	8.4 / 8.8
	G30	%	9.9 / 10.6
	G31	%	9.8 / 10.2
O ₂ (%) at minimum/maximum power	G20	%	5.8 / 5.4
	G25	%	5.6 / 4.9
	G30	%	6.2 / 5.1
	G31	%	6.0 / 5.4
Maximum recirculation of flue gas permitted in windy conditions		%	10
Maximum flue gas temperature at boiler outlet		°C	80
Minimum flue gas temperature at boiler outlet		°C	30
Δt fumes temperature/Return (at 100% of the load) (80/60)		°C	24
Δt fumes temperature/Return (at 30% of the load) (37/30)		°C	7
Maximum CO in exhaust fumes		ppm	250
Mass flow of fumes at maximum power		g/s	32.9
Mass flow of fumes at minimum power		g/s	7.1
Hydraulic head available at outlet		Pa	110
Maximum temperature of the combustion agent air		°C	40
Maximum CO ₂ content in the combustion agent air		%	0.9
Maximum fumes temperature for overheating		°C	95
Max. negative pressure allowed in the flue gas exhaust/air intake system		Pa	110
Condensate maximum flow rate		l/h	8.8
Condensate average acidity		pH	4
Operating room temperature		°C	0.5 ; + 50
Boiler weight (empty)		kg	98

19 - TECHNICAL DATA

19.1 - MYDENS TECHNICAL DATA

140T	210T	280T
300	430	590
110	160	160
10	10	10
10	10	10
4	4	4
27	27	27
34	34	34
8.5 / 8.7	8.5 / 8.7	8.5 / 8.7
8.4 / 8.8	8.4 / 8.8	8.4 / 8.8
9.9 / 10.6	9.9 / 10.6	9.9 / 10.6
9.8 / 10.2	9.8 / 10.2	9.8 / 10.2
5.8 / 5.4	5.8 / 5.4	5.8 / 5.4
5.6 / 4.9	5.6 / 4.9	5.6 / 4.9
6.2 / 5.1	6.2 / 5.1	6.2 / 5.1
6.0 / 5.4	6.0 / 5.4	6.0 / 5.4
10	10	10
80	80	80
30	30	30
24	24	24
7	7	7
250	250	250
65.8	98.7	131.7
7.1	7.1	7.1
110	110	110
40	40	40
0.9	0.9	0.9
95	95	95
110	110	110
17.6	26.3	35.1
4	4	4
0.5 ; + 50	0.5 ; + 50	0.5 ; + 50
147	211	249

19 - TECHNICAL DATA

19.2 - AGUADENS TECHNICAL DATA

AGUADENS TECHNICAL DATA		UM	70T
Type (Type of flue gas exhaust/air intake)			B23 ; B23P
Category			I12H3P
EU type approval certificate (PIN)			0476CR1272
Max. heat input "Qn" PCI (PCS)		kW	69.9 (77.6)
Min. heat input "Qm" PCI (PCS)		kW	14.7 (16.3)
Max. useful output power (50/30) "Pn"		kW	73.5
Efficiency at max. useful output power (50/30) PCI (PCS)		%	105.1 (94.7)
Min. useful output power (50/30) "Pm"		kW	15.6
Efficiency at min. useful output power (50/30) PCI (PCS)		%	106.3 (95.8)
Gas flow rate	G20	m ³ /h	7.39
	G25	m ³ /h	8.60
	G30	kg/h	5.51
	G31	kg/h	5.43
Gas supply pressure	G20	mbar	20
	G25	mbar	25
	G30	mbar	30
	G31	mbar	37
Gas supply minimum pressure	G20	mbar	17
	G25	mbar	20
	G30	mbar	25
	G31	mbar	25
Gas supply maximum pressure	G20	mbar	25
	G25	mbar	30
	G30	mbar	35
	G31	mbar	45
Primary heat exchanger water content		l	5.7
Minimum operating water flow rate with motorised valves		l/h	/
Minimum operating water flow rate without motorised valves		l/h	2700
Instant DHW production (dt 30°C)		l/min	35.3
Instant DHW adjustment range		°C	20 - 80
Maximum temperature for safety intervention		°C	95
Maximum pressure "PMS"		bar	11
Minimum pressure		bar	1
Rated power supply voltage		V	230
Rated power supply frequency		Hz	50
Absorbed electrical power		W	150
Electrical protection rating			IP20

19 - TECHNICAL DATA

19.2 - AGUADENS TECHNICAL DATA

140T	210T	280T
B23 ; B23P		
I12H3P	I12H3P	I12H3P
0476CR1272	0476CR1272	0476CR1272
140.0 (155.4)	210.0 (233.1)	280.0 (310.8)
14.7 (16.3)	14.7 (16.3)	14.7 (16.3)
147.1	220.7	294.3
105.1 (94.7)	105.1 (94.7)	105.1 (94.7)
15.6	15.6	15.6
106.3 (95.8)	106.3 (95.8)	106.3 (95.8)
14.80	22.20	29.61
17.22	25.83	34.43
11.03	16.55	22.06
10.87	16.30	21.73
20	20	20
25	25	25
30	30	30
37	37	37
17	17	17
20	20	20
25	25	25
25	25	25
25	25	25
30	30	30
35	35	35
45	45	45
11.4	17.1	32.8
2700	2700	2700
5400	10800	10800
70.7	106.0	141.4
20 - 80	20 - 80	20 - 80
95	95	95
11	11	11
1	1	1
230	230	230
50	50	50
300	430	590
IP20	IP20	IP20

19 - TECHNICAL DATA

19.2 - AGUADENS TECHNICAL DATA

AGUADENS TECHNICAL DATA		UM	70T
Burner electrical power		W	150
Air intake and flue gas exhaust pipe diameter (split)		mm	110
Max. length of flue gas outlet duct (split)		m	10
Air intake pipe max. length (split)		m	10
Equivalent length of a bend		m	4
Weighted CO (0% O2)	G20	ppm	27
Weighted NOx (0% O2) (EN 26:2015) PCS	G20	mg/kWh	34
CO2 (%) at minimum/maximum power	G20	%	8.5 / 8.7
	G25	%	8.4 / 8.8
	G30	%	9.9 / 10.6
	G31	%	9.8 / 10.2
O2 (%) at minimum/maximum power	G20	%	5.8 / 5.4
	G25	%	5.6 / 4.9
	G30	%	6.2 / 5.1
	G31	%	6.0 / 5.4
Maximum recirculation of flue gas permitted in windy conditions		%	10
Maximum flue gas temperature at boiler outlet		°C	80
Minimum flue gas temperature at boiler outlet		°C	30
Mass flow of fumes at maximum power		g/s	32.9
Mass flow of fumes at minimum power		g/s	7.1
Hydraulic head available at outlet		Pa	110
Maximum temperature of the combustion agent air		°C	40
Maximum CO2 content in the combustion agent air		%	0.9
Maximum fumes temperature for overheating		°C	95
Max. negative pressure allowed in the flue gas exhaust/air intake system		Pa	110
Condensate maximum flow rate		l/h	8.8
Condensate average acidity		pH	4
Operating room temperature		°C	0.5 ; + 50
Boiler weight (empty)		kg	98

19 - TECHNICAL DATA

19.2 - AGUADENS TECHNICAL DATA

140T	210T	280T
300	430	590
110	160	160
10	10	10
10	10	10
4	4	4
27	27	27
34	34	34
8.5 / 8.7	8.5 / 8.7	8.5 / 8.7
8.4 / 8.8	8.4 / 8.8	8.4 / 8.8
9.9 / 10.6	9.9 / 10.6	9.9 / 10.6
9.8 / 10.2	9.8 / 10.2	9.8 / 10.2
5.8 / 5.4	5.8 / 5.4	5.8 / 5.4
5.6 / 4.9	5.6 / 4.9	5.6 / 4.9
6.2 / 5.1	6.2 / 5.1	6.2 / 5.1
6.0 / 5.4	6.0 / 5.4	6.0 / 5.4
10	10	10
80	80	80
30	30	30
65.8	98.7	131.7
7.1	7.1	7.1
110	110	110
40	40	40
0.9	0.9	0.9
95	95	95
110	110	110
17.6	26.3	35.1
4	4	4
0.5 ; + 50	0.5 ; + 50	0.5 ; + 50
147	211	249

20 - FORCED MENU

Ref.	Parameter description	Adjustment field	Factory value	MYDENS boiler parameters		
				Single burner (mod. 70T)	Burner 1 (Master) (mod. 140T, 210T and 280T)	Burners 2 to 4 (mod. 140T, 210T and 280T)
3001	Burner operation address	0 = Not in cascade, 1 = Burner 1 (Master), 2 to 4 = Burners 2 to 4 (slave burners)	2	0	1	from 2 to 4
3002	Fan adjustment field	from 0 to 4	0	70 = 2	140, 210 and 280 = 2	
3003	Unit of measurement of display	C = °C and bar; F = °F and PSI;	C	C	C	C
3004	Water pressure switch	0 = Disabled; 1 = Enabled; 2 = N/A; 3 = N/A	1	1	1	0
3005	Burner flapper valve	0 = Disabled; 4 = Enabled; 8 = N/A; 12 = N/A;	4	0	4	4
3006	Water flow rate sensor	0 = Disabled; 16 = N/A; 32 = N/A; 48 = Enabled	48	48	48	48
3007	Condensate level sensor	EnAb = Enabled; dISA = Disabled	Enab	Enab	Enab	dISA
3008	Exhaust gases type sensor	SEnS = Sensor; StCH = Switch	SEnS	SEnS	SEnS	SEnS
3009	Type of external sensor	10 = 10kohms; 12 = 12kohms;	10	10	10	10
3010	Type of other sensors	10 = 10kohms; 12 = 12kohms;	10	10	10	10
3011	pump mode	0 = primary c pump; 1 = N/A; 2 = N/A; 3 = N/A;	0	0	0	0
3012	DHW operation mode	0 = only central heating; 1 = storage tank with puffer; 2 = storage tank with thermostat; 3 = N/A; 4 = N/A; 5 = N/A	0	0 = only central heating; 1 = storage tank with puffer;	0 = only central heating; 1 = storage tank with puffer;	0
3013	Reset Err 115	EnAb = Enabled; dISA = Disabled	Enab	Enab	Enab	Enab
3015	Climate control: maximum central heating delivery temperature (this parameter is overwritten by parameter 3017)	from 20°C to 90°C	82°C	82°C	82°C	82°C
3016	Climate control: minimum central heating delivery temperature	from 20°C to 90°C	20°C	20°C	20°C	20°C
3017	Maximum delivery temperature (this parameter takes priority over parameter 3015)	from 20°C to 90°C	82°C	82°C	82°C	82°C
3018	Minimum delivery temperature	from 20°C to 90°C	32°C	32°C	32°C	32°C
3020	Type of water flow rate sensor	0 = N/A; 1 = DN8; 2 = DN 10; 3 = DN 15; 4 = DN 20; 5 = DN 25	4	4	4	4
3022	Minimum water pressure	from 0 to 5 bar	1	1	1	1
3035	Minimum water flow rate	from 0 to 100 l/min	27	70 = 45	140, 210 and 280 = 45	140, 210 and 280 = 45
3050	Number of slave burners	from 0 to 3	3	3	140=1 210 = 2 280 = 3	3
3085	Modbus address	0 to 126	1	1	1	1
3086	Number of Stopbits	1 or 2	1	1	1	1
3100	Material selection	ABS; CPVC; PVC; SST; PP.	PVC	PVC	PVC	PVC
3101	Nation selection	US, CA	US	US	US	US
" S 4 " switch	"S4" Switch Position (see fig 18-11 and 18-12)	On or Off	On	On	On	Off

N/A = Not Applicable

20 - FORCED MENU

AGUADENS hot water heater parameters			
Single burner (mod. 70T)	Burner 1 (Master) (mod. 140T, 210T and 280T)	Burners 2 to 4 (mod. 140T, 210T and 280T)	Customised values
0	1	from 2 to 4	
70 = 2	140, 210 and 280 = 2		
C	C	C	
1	1	0	
0	4	4	
48	48	48	
Enab	Enab	dISA	
SEnS	SEnS	SEnS	
10	10	10	
10	10	10	
0	0	0	
0 = only central heating; 1 = storage tank with puffer;	0 for instant DHW; 1 for puffer tank.	0	
Enab	Enab	Enab	
N/A	N/A	N/A	
N/A	N/A	N/A	
82°C	82°C	82°C	
32°C	32°C	32°C	
4	4	4	
1	1	1	
70 = 45	140, 210 and 280 = 45	140, 210 and 280 = 45	
3	140 = 1 210 = 2 280 = 3	3	
1	1	1	
1	1	1	
PVC	PVC	PVC	
US	US	US	
On	On	Off	



WARNING! Changing these parameters could cause boiler and therefore system malfunctions. For this reason only a professionally qualified technician with awareness and in-depth knowledge of the boiler can change them.



WARNING! By going into the forced menu the boiler may start working; paying no regard to this may cause harm to people, animals or things.



WARNING! If it is a multi-burner boiler (models from 140T to 280T) the display is always connected to burner 1 (MASTER); to set the parameters in the other burners you need to connect the display to them as shown in section 18.8.



The forced menu allows the boiler to be set according to the system to be provided. Setting is done by adjusting the parameters available (shown in the table).





To access the forced menu, proceed as follows:

1 - Turn off electricity to the boiler by moving the main switch to OFF;

2.- Hold down both the RESET and the  button and move the main switch to ON;

3.- Wait for the display to show the word "INIT" or the parameters **3000**.

4. - Using buttons  + and  scroll through the list of parameters **3000**;

5.- Browse the menu with buttons  + and . Once the parameter is selected, press the RESET button to make it possible to change it using buttons  + and ;











6.- Press the RESET button to save the changes;

7.- Wait for 10 seconds;

8 - Turn off electricity to the boiler;

9.- Turn electricity to the boiler back on to exit the forced menu and return to normal operation.

21 - COMMAND MENU DIAGRAM

Symbol	Description
RESET 0 	Press and release RESET button
RESET 2 	Hold down RESET button for 2 seconds
RESET 5 	Hold down RESET button for 5 seconds
RESET 5  	At the same time, hold down, for the number of seconds shown by the number, the two buttons RESET and 
	Press and release button 
	Press and release button 

21 - COMMAND MENU DIAGRAM

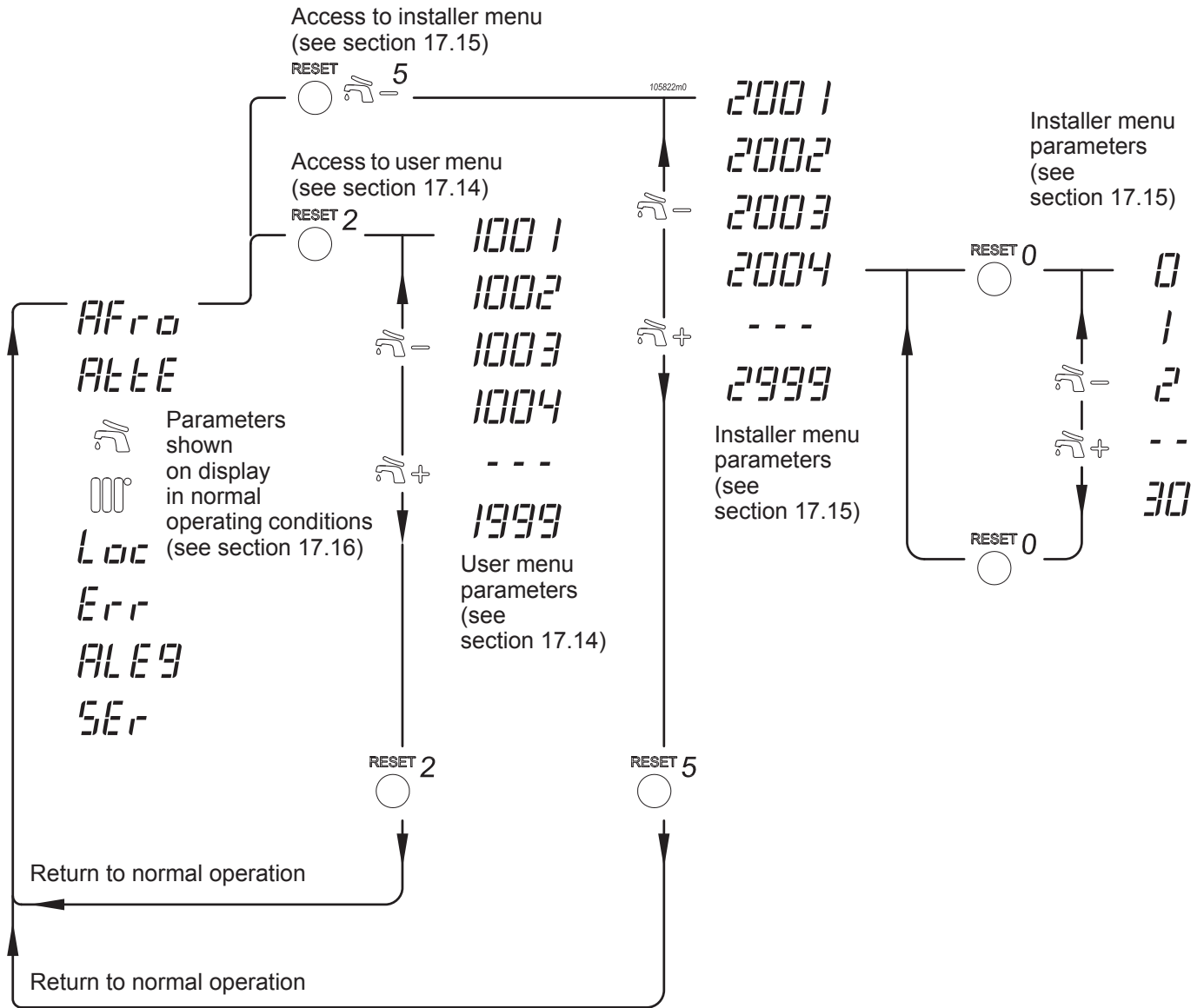
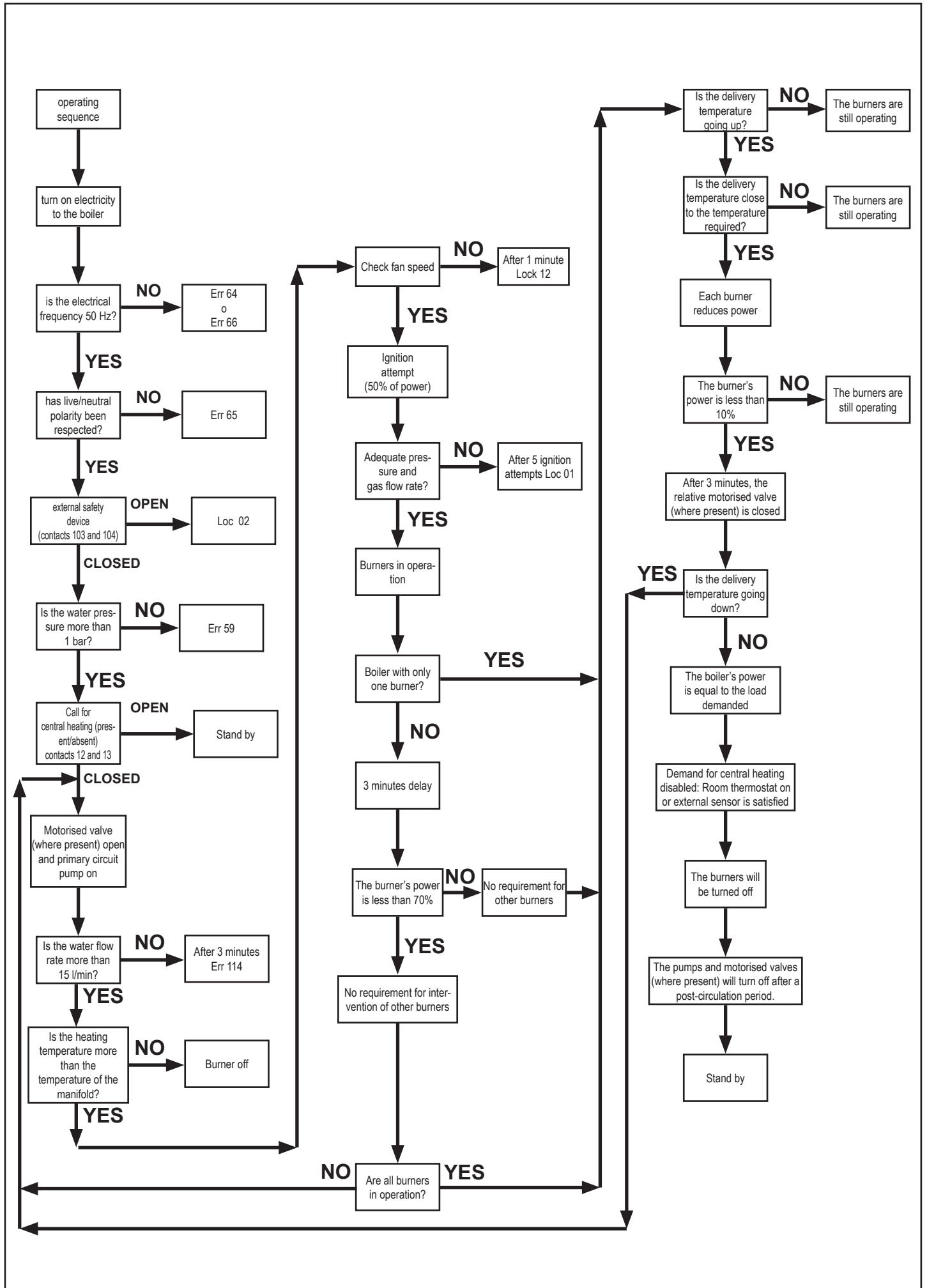
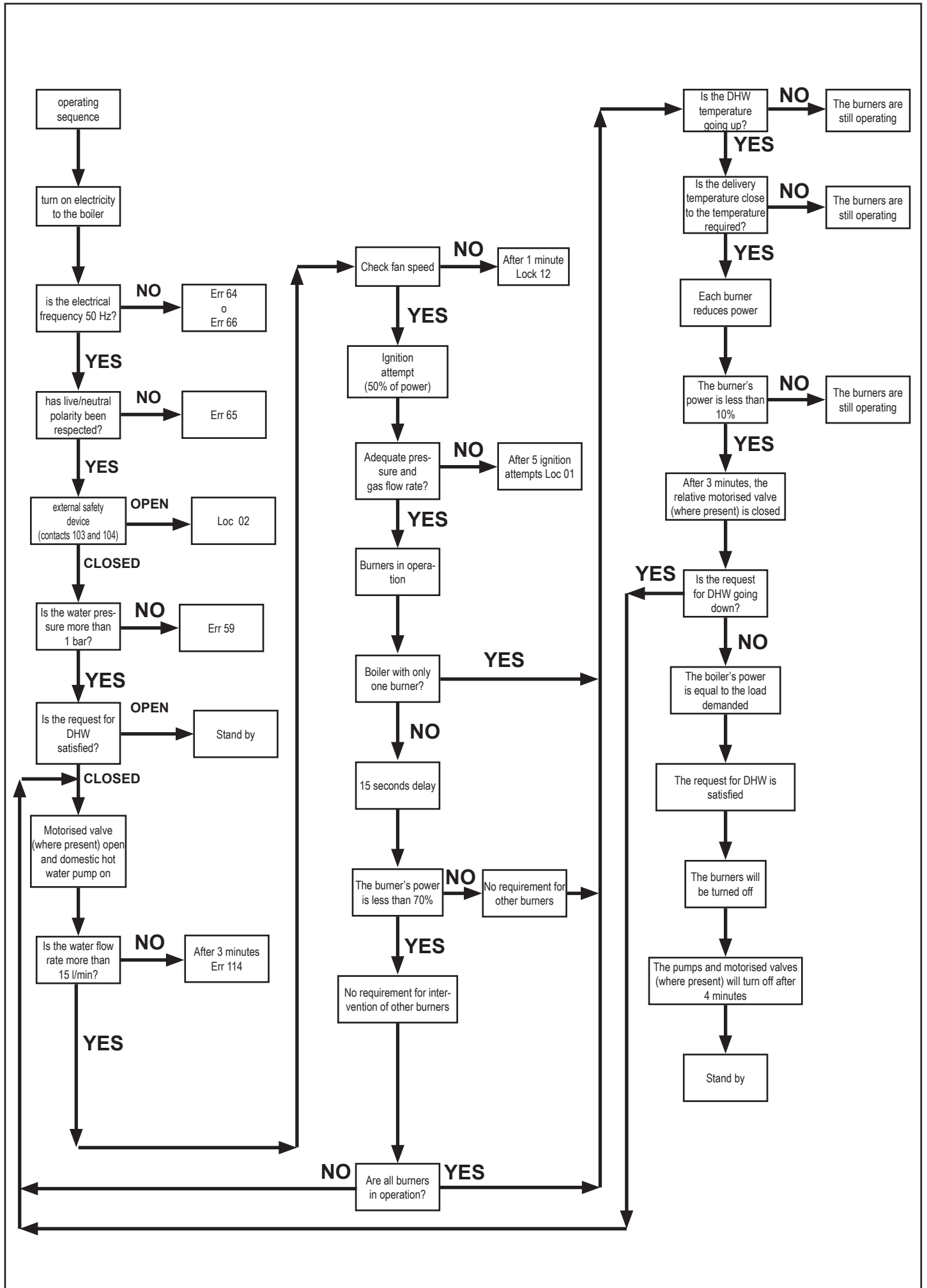

Figure 21-1 - Command menu diagram

22 - BOILER OPERATING SEQUENCE



23 - HOT WATER HEATER OPERATING SEQUENCE



24 - MYDENS PRODUCT FILE

Name or brand of the supplier			ADVECO
Supplier's model number			MYDENS
			70T
Condensing boiler			YES
Low-temperature boiler			NO
B1 boiler			NO
Cogeneration space heater			NO
Combination heater			NO
Equipped with supplementary heater			NO
Energy efficiency class			A
Item	Symbol	Unit	
Rated heat output	Pn	kW	67.9
Seasonal space heating energy efficiency	η_s	%	90.8
Useful output power at rated heat output in high-temperature regime (*)	P4	kW	67.9
Useful efficiency at rated heat output in high-temperature regime (*)	η_4	%	87.3
Useful output power at 30% of rated heat input in low-temperature regime (**)	P1	kW	22.6
Useful efficiency at 30% of rated heat input in low-temperature regime (**)	η_1	%	95.8

Auxiliary electricity consumption

At full load	elmax	kW	0.14
At partial load	elmin	kW	0.06
In standby mode	Psb	kW	0.005

Other factors

Standby heat loss	Pstby	kW	0.1
Ignition burner power consumption	Pign	kW	0
Annual energy consumption	QHE	GJ	130
Sound power level, indoors/outdoors	LWA	dB	70
Emissions of nitrogen oxides	NOx	mg/kWh	34

Domestic hot water parameters

Declared load profile			N/A
DHW production efficiency	η_{wh}	%	N/A
Daily consumption of electrical energy	Qelec	kWh	N/A
Annual consumption of electrical energy	AEC	kWh	N/A
Daily consumption of fuel	Qfuel	kWh	N/A
Annual consumption of fuel	AFC	GJ	N/A

According to Regulations (EU) no. 811/2013 and no. 813/2013.

N/A = Not applicable.

(*) High-temperature regime means 60°C return temperature and 80°C supply temperature.

(**) Low-temperature regime for condensing boilers means 30°C, for low-temperature boilers, 37°C, and for other appliances, 50°C return temperature

24 - MYDENS PRODUCT FILE

ADVECO		
MYDENS		
140T	210T	280T
YES	YES	YES
NO	NO	NO
NO	NO	NO
NO	NO	NO
NO	NO	NO
NO	NO	NO
-	-	-

135.8	203.7	271.6
91.0	91.1	91.1
135.8	203.7	271.6
87.3	87.3	87.3
45.3	67.9	90.5
95.8	95.8	95.8

0.28	0.42	0.56
0.06	0.06	0.06
0.01	0.015	0.02

0.2	0.3	0.4
0	0	0
237	345	452
70	70	70
34	34	34

N/A	N/A	N/A
N/A	N/A	N/A
N/A	N/A	N/A
N/A	N/A	N/A
N/A	N/A	N/A
N/A	N/A	N/A

25 - AGUADENS PRODUCT FILE

(a) Name or brand of supplier			ADVECO
(b) Supplier's identifying model number			AGUADENS
			70T
(c) Declared load profile			XXL (1)
(d) Class of energy efficiency			A
(e) Domestic hot water production efficiency	η_{wh}	%	85.6
(f) Daily consumption of electrical energy	Qelec	kWh	0.19
(f) Annual consumption of electrical energy	AEC	kWh	42
(f) Daily consumption of fuel	Qfuel	kWh	28.172
(f) Annual consumption of fuel	AFC	GJ	22
(g) Other load profile			-
(g) Domestic hot water production efficiency*		%	-
(g) Daily consumption of electrical energy *		kWh	-
(g) Annual consumption of electrical energy *		kWh	-
(g) Daily consumption of fuel *		kWh	-
(g) Annual consumption of fuel *		GJ	-
(h) Water heater thermostat temperature adjustment			°C
(i) Level of sound power inside		LWA	dB
(j) The water heater can only operate during slack times			NO
(k) any eventual specific precautions to take during assembly, installation or maintenance of the water heater.			Read the instructions for the installation, use and maintenance of the product.
(l) Smart control factor			N/A
Emissions of nitrogen oxides		NOx	mg/kWh
			34

In agreement with European Ruling (EU) No 812/2013 and No 814/2013;

- (1) with MULTITANK 200 storage tank;
- (2) with MULTITANK 300 storage tank;
- (3) with MULTITANK 800 storage tank;

* Related to other load profile (g);

N/A = Not Applicable;

25 - AGUADENS PRODUCT FILE

ADVECO		
AGUADENS		
140T	210T	280T
3XL (2)	4XL (3)	4XL (3)
-	-	-
83.1	83.5	83.2
0.36	0.51	0.54
79	112	118
55.356	110.778	111.111
44	88	88
-	-	-
-	-	-
-	-	-
-	-	-
-	-	-
-	-	-
60	60	60
70	70	70
NO	NO	NO
Read the instructions for the installation, use and maintenance of the product.		
N/A	N/A	N/A
34	34	34

The undersigned company **COSMOGAS S.r.L.**, with registered office in Via L. Da Vinci no. 16 - 47014 Meldola (FC) ITALY,

DECLARES

under its own responsibility that the product:

SERIAL No.	-----
MODEL	-----
PRODUCTION	-----

that is the subject of this declaration, complies with the model described in **EU** Type Test Certificate, issued by the notified body Kiwa Cermet Italia S.p.A., whose data are given in the table shown in the TECHNICAL DATA section under the heading “ EC type approval certificate (PIN)”, and fulfils the requirements of the EU Regulation on Gas Appliances, (**2016/426**), the Efficiency Directive, (**92/42/EEC** modified by **Reg. (EU) 813/2013**), the Low Voltage Directive, (**2014/35/EU**), and the Electromagnetic Compatibility Directive, (**2014/30/EU**).

Monitoring of the product was carried out by the notified body shown on form “C”.

(The warranty number corresponds to the serial number)

This declaration is issued as stipulated by the aforementioned directives.

Meldola (FC) ITALY, (Date of construction).



The logo for Cosmogas S.r.L. features a circular emblem on the left containing the word 'CALDATE' and a stylized flame or gas symbol. To the right of the emblem, the word 'COSMOGAS' is written in a bold, sans-serif font. A handwritten signature in black ink is overlaid across the 'COSMOGAS' text.

Alessandrini Arturo
Sole Director

To contact technical support



Unit 7&8 Armstrong Mall, Southwood Business Park
Farnborough, Hampshire GU14 0NR

PHONE 01252 551 540
enquiries@adveco.co
www.adveco.co