

ADVECO

EXPERTLY ENGINEERED FOR YOU



MD Boiler Range



Adveco High Efficiency Condensing Boilers

The Adveco MD is a range of four floor-standing and 10 wall mounted boilers designed to provide a high capacity and reliable solution to a building's central heating and DHW demands. Floor standing models with heat inputs from 70 to 280 kW are suitable for a wide range of heating applications. Compact wall mounted variants offer rated heat outputs of 15, 24, 34 and 60 kW.

Manufactured by our European partner with more than 50 years of experience in boiler production, the MD range delivers quality and reliability you can trust for all your commercial heating and DHW projects

Fully modulating with condensing technology

Modern, innovative and compact design

Outputs from 14 kW to 2.24 MW



MD70T-MD280T Floor Standing

106%

HIGH EFFICIENCY



LOW NO_x

34

mg/kWh

10

YEAR HEAT
EXCHANGER
WARRANTY

Features & Benefits

Fully condensing with low flue gas temperatures
Improves energy efficiency
Enables use of low-cost PP flues

11 bar working pressure
Suitable for large, high pressure applications

Integrated flue gas non-return valve
Enables overpressure flue systems
Prevents flue gas recirculation

Intelligent system controller
Includes maintenance self-check
0-10, MODBUS, and alarm outputs for BMS
integration

Acid condensate neutraliser
Refillable limestone bed reduces acidity

Space saving design
Stackable heat exchanger design delivers maximum
output from minimal footprint

EXPERTLY ENGINEERED FOR YOU

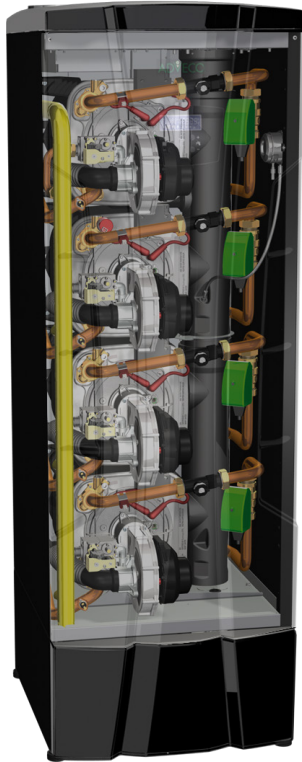

The Strength To Out Perform Others

Multiple heat exchangers from MD 140T and up

Combining two, three, or four 70 kW heat engines within a single floor standing chassis. Each heat exchanger incorporates a control board providing load balancing for uniform wear and built-in redundancy

Continuous non-welded run and large bore, three-pass design

Durable and corrosion resistant titanium-stabilised stainless steel construction provides high-capacity heat transfer, high flow rates, with minimal pressure loss and reduced debris to collect

10-year heat exchanger and burner warranty

Peace of mind with long-term warranty from failure or manufacturing defect. Includes seven year warranty for all parts and labour.

Advenco MD Boiler featuring AISI 316Ti titanium-stabilised stainless steel heat exchangers



MD70T-MD280T Floor Standing

Efficient pre-mix burners available for natural gas and LPG

Achieves ideal combustion to minimise carbon and NO_x emissions.
CO as low as 19 ppm

106% combustion efficiency

Reduces energy costs and emissions via efficient use of fuel energy

Low emission, NO_x class 6 appliance at 34 mg/kWh

Reduces harmful emissions and satisfies the requirements of the Energy-related Products (ErP) directive

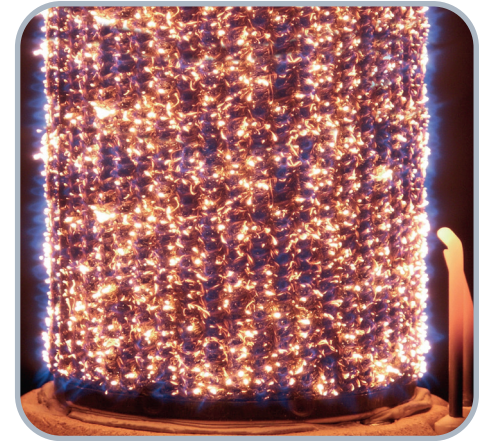

MD in Cascade

Connect up to eight MD280T units in cascade for 2240kW
No framework requirement for immediate cost savings
Occupies minimal plant room floor space

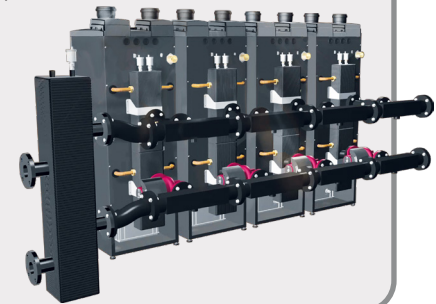
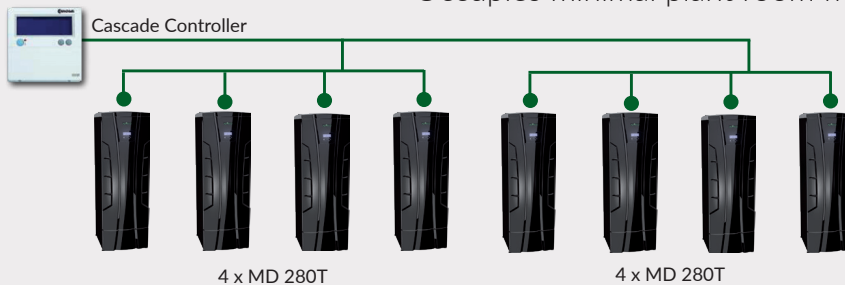

EXPERTLY ENGINEERED FOR YOU

MD Wall Mounted Range

Quality Comes As Standard

- Extremely high quality AISI 316Ti heat exchangers for lasting reliability and efficiency
- High efficiency pre-mix burner provides large modulation range
- Compact wall-hung arrangement
- Ultra-low NO_x emissions
- Available using natural gas or LPG
- Standard concentric flue systems using low cost 80/125 mm diameter PP
- Integrated run/fault signal for connection to BMS
- Seven years warranty on all parts when commissioned by Advenco (Terms & Conditions apply)

**For Light Commercial Heating &
Domestic Hot Water Applications**



MD Wall Mounted Range



MD 15 / MD 24 / MD 34

The MD 15, 24 and 34 range is available in three variations

The MD 15C, MD 24C and MD 34C models serve as boilers for central heating purposes only

The MD15B, 24B and 34B feature additional connections for use with an indirect water heater to provide domestic hot water

The MD 24P and 34P alternatively feature an integrated plate heat exchanger for compact and instantaneous DHW production

The MD60 is a wall-hung condensing boiler with a rated heat output of 60 kW

Two variants offer a choice of with (MD60C) or without (MD60A) an integrated system pump

MD 60



EXPERTLY ENGINEERED FOR YOU

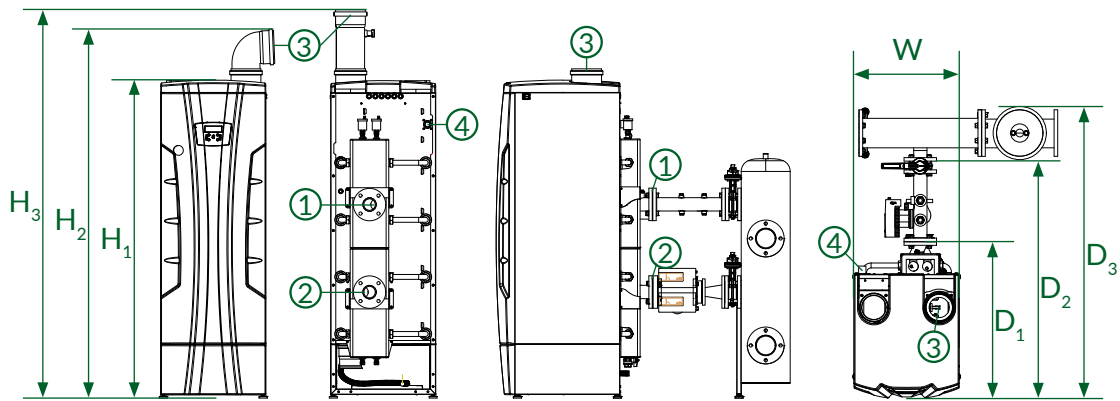

MD70T -MD280T Dimensions and Connections

Port	MD 70T	MD 140T	MD 210T	MD 280T
1 : Flow	1 ½ "	1 ½ "	DN65 PN16	DN65 PN16
2 : Return	1 ½ "	1 ½ "	DN65 PN16	DN65 PN16
3 : Flue Exhaust	Ø110 mm	Ø110 mm	Ø160 mm	Ø160 mm
4 : Gas Inlet	1 "	1 "	1 ¼ "	1 ¼ "
H ₁ : Unit height	1180 mm	1180 mm	1880 mm	1880 mm
H ₂ : Height including 90° bend	1310 mm	1310 mm	2085 mm	2085 mm
H ₃ : Height including flue test point	1445 mm	1445 mm	2165 mm	2165 mm
W : Unit width	600 mm	600 mm	600 mm	600 mm
D ₁ : Unit depth	945 mm	945 mm	896 mm	896 mm
D ₂ : Depth including rear manifold	n/a	n/a	1356 mm	1356 mm
D ₃ : Depth including cascade	n/a	n/a	1664 mm	1664 mm
Front clearance	1000 mm	1000 mm	1000 mm	1000 mm
Vertical clearance	500 mm	500 mm	500 mm	500 mm
Horizontal clearance	100 mm	100 mm	100 mm	100 mm
Rear clearance	500 mm	500 mm	500 mm	500 mm



Technical Specifications		Units	MD 70T	MD 140T	MD 210T	MD 280T
Net heat input range	Maximum Minimum	kW	69.9 14.7	140.0 14.7	210.0 14.7	280.0 14.7
Heat output range (80/60)	Maximum Minimum	kW	67.9 14.1	135.8 14.1	203.7 14.1	271.6 14.1
Maximum efficiency (80/60)	At max. output At min. output	%	96.0 97.0	96.0 97.0	96.0 97.0	96.0 97.0
Heat output range (50/30)	Maximum Minimum	kW	74.0 15.6	148.0 15.6	222.0 15.6	296.0 15.6
Maximum efficiency (50/30)	At max. output At min. output	%	106.0 106.0	106.0 106.0	106.0 106.0	106.0 106.0
Efficiency at 30% load (92/42/EEC Certificate: ★★★★★)		%	106.0	106.0	106.0	106.0
Nominal water flow rate		l / s	0.83	1.66	2.50	3.32
Pressure loss at nominal flow rate		kPa	48	50	50	50
Heat exchanger water capacity		l	7.57	15.14	22.71	30.28
Heating temperature range		°C	20 - 80	20 - 80	20 - 80	20 - 80
System pressure range		bar	1 - 11	1 - 11	1 - 11	1 - 11
Supply		V / Hz	230 / 50	230 / 50	230 / 50	230 / 50
Electrical consumption	Maximum Minimum	W	140 60	280 60	420 60	560 60
Gas flow rate	Natural gas LPG	m ³ /h kg/h	7.40 5.43	14.80 10.87	22.20 16.30	29.61 21.73
NO _x emissions (0% O ₂ with natural gas. EN 15502 Class 6)		mg/kWh GCV	34	34	34	34
CO emissions		ppm	19	19	19	19
Approved flue types			B23	B23	B23	B23
Flue gas mass flow rate		kg/h	115	230	345	460
Flue gas temperature at outlet	Maximum Minimum	°C	90 30	90 30	90 30	90 30
Appliance Mass	Empty Full	kg	98 106	147 162	211 234	249 279

EXPERTLY ENGINEERED FOR YOU

Boiler Ancillaries	2 Manifold Spacer	3 Low Loss Header For Single Boiler	4 Pump	5 Pump Adaptor Cone	Flange Elbow Set
MD 70T	n/a	200 kW: 0310335	Single head: M0132 (1 per boiler)	n/a	n/a
MD 140T	n/a	200 kW: 0310335	Single head: M0133 (1 per boiler)	n/a	n/a
MD 210T	M0127 (1 per boiler)	DN65 360 kW: 61213005	Single head: M0063 Twin head: MB0039 (1 per boiler)	DN40-DN65: M0128A (2 per pump)	DN65: 62660010
MD 280T	M0127 (1 per boiler)	DN65 360 kW: 61213005	Single head: M0063 Twin head: MB0039 (1 per boiler)	DN40-DN65: M0128A (2 per pump)	DN65: 62660010

Cascade Ancillaries	1 Manifold Kit	3 Low Loss Header For Boiler Cascade	6 Isolation Valve	Cascade Sequencer
MD 210T	2 Boilers DN100: 62660011	DN100 560 kW: 61213006	DN65: 62660014 (2 per boiler)	62110101 (1 per system)
	3 Boilers DN150: 62660012			
	4 Boilers DN150: 62660013	DN150 1400 kW: 61213007		
	5 Boilers DN150: 62660015			
	2 Boilers DN100: 62660011	DN100 560 kW: 61213006		
3 Boilers DN150: 62660012	DN150 1400 kW: 61213007			
4 Boilers DN150: 62660013				
MD 280T	5 Boilers DN150: 62660015		DN65: 62660014 (2 per boiler)	62110101 (1 per system)





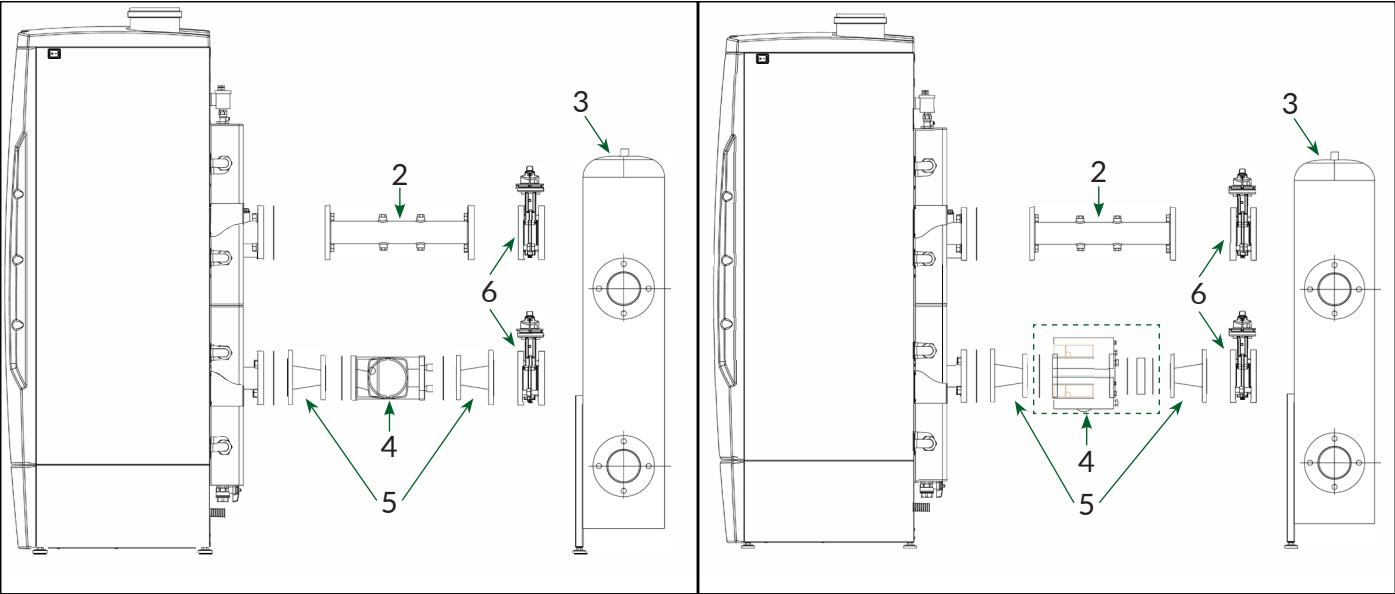

MD70T-MD280T Floor Standing



Single Pump

Twin Pump

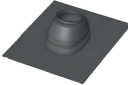
EXPERTLY ENGINEERED FOR YOU

Standard Flue	Size:	110 mm PP	160 mm PP	200 mm PP
Suitable for:		MD 70T; MD 140T	MD 210T; MD 280T MD 70T*; MD 140T*	MD 210T*; MD 280T*
*: Requires adaptor to upsize flue:			110-160mm: 0718025	160-200mm: 071823
Flue Terminals		Vertical: MB0025 Horizontal: MB0028	0718761 100035790094	0718762 100035790004
Flue Extension 1m			0718102	0718132
Flue Bends		45° Bend: 0718140 90° Bend: 0718141	0718160 0718161	0718170 0718171
Roof Flashings		Flat: 0146184 15-55° Pitched: MB0033	0746066 100035790099	0146185 100035790003
Flue Bracket			0169158	200050718012
Flue Test Point Extensions		<i>Included as standard</i>	<i>Included as standard</i>	<i>Included as standard</i>



External flue size:	110/160 mm PP/SS	160 mm/225 mm PP/SS	200 mm/300 mm PP/SS
Suitable for:	MD 70T; MD 140T	MD 210T; MD 280T <i>MD 70T*; MD 140T*</i>	MD 210T*; MD 280T*
*: Requires adaptor:		110-160 mm: 0718025	M/F 160-200 mm: 071823

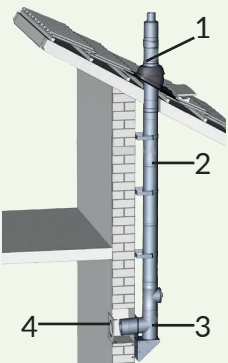

1, 3, 4: External Riser Kit:	MB0026	MB0029	MB0031
2: 1m Extension Kit:	MB0027	MB0030	MB0032
45° External Bend:	n/a	200075045316	200075045916
90° External Bend:	n/a	200075045326	200075045926

Maximum Flue Runs		110 mm PP	160 mm PP	200 mm PP
MD 70T	Straight Run:	19.1 m	41.1 m	65.2 m
	Loss Per Bend (45°/90°):	- 1.2 m / - 2.8 m	- 1.2 m / - 2.8 m	- 1.2 m / - 2.8 m
MD 140T	Straight Run:	10.0 m	21.5 m	34.1 m
	Loss Per Bend (45°/90°):	- 2.0 m / - 4.0 m	- 1.2 m / - 2.8 m	- 1.2 m / - 2.8 m
MD 210T & MD280T	Straight Run:	n/a	10.0 m	15.9 m
	Loss Per Bend (45°/90°):		- 2.0 m / - 4.0 m	- 1.2 m / - 2.8 m

EXPERTLY ENGINEERED FOR YOU

MD Wall Mounted Range Connections & Technical Specifications

MD 15 /24 /34

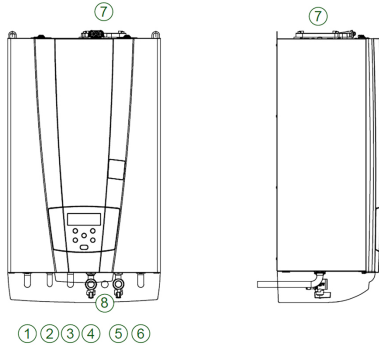

MD 60

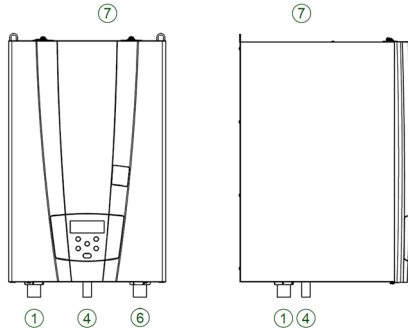

Connections

Port	Purpose	MD 15 / 24	MD 34	MD 60
1	Flow to heating	¾" (20 mm)	1" (26 mm)	1 ½" (42 mm)
2 (B)	Flow to indirect tank (Present on B models only)	¾" (20 mm)		-
2 (P)	DHW flow (present on P models only)	½" (13 mm)		-
3 (B)	Indirect tank return (present on B models only)	¾" (20 mm)		-
4	Gas inlet		¾" (20 mm)	
5	Water filling connection (P models: DHW return)	½" (13 mm)		-
6	Heating return	¾" (20 mm)	1" (26 mm)	1 ½" (42 mm)
7	Flue outlet		Parallel: Ø80 mm Concentric: Ø60/100 mm	Concentric Ø80/125 mm
8	Condensate drain		¾" (20 mm)	-

Ancillaries & Flue Components

Each MD wall mounted boiler must be equipped with one of the following flue adaptor kits:

MD 15 / 24 / 34 Boiler Adaptors

- Horizontal Coaxial Vent Kit Ø60/100 PP. Part number: 62617228
- Vertical Coaxial Adaptor Ø60/100 PP. Part number: 62617224
- Split System Vent Adaptor Ø80x2 PP. Part number: 62617226

MD 60 Boiler Adaptors

- Concentric to parallel flue adapter for separated air intake and flue gas outlet. Part number: 62617315
- Concentric flue coupling. Aluminium / PP. Part number: 62617314

For further information and specifications on the full range of available flues and ancillaries, please contact the Adveco application design department at: technical@adveco.co or 01252 551 540

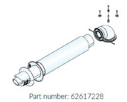

Part number: 62617228



Part number: 62617224



Part number: 62617226



Part number: 62617315



Technical Specifications		Units	MD 15 (C/B)	MD 24 (C/B/P)	MD 34 (C/B/P)	MD 60 (A/C)
Net heat input range	Maximum Minimum	kW	14.0 3.2	25.5 3.2	32.0 6.0	57.8 12/0
Heat output range (80/60)	Maximum Minimum	kW	13.6 3.02	24.8 3.02	30.9 5.75	56.1 11.6
Maximum efficiency (80/60)	At max. output At min. output	%	96.5 94.5	97.2 94.5	96.8 95.8	97.1 97.0
Heat output range (50/30)	Maximum Minimum	kW	14.9 3.30	27.0 3.30	33.5 6.14	60.7 12.8
Maximum efficiency (50/30)	At max. output At min. output	%	106.5 103.0	105.7 103.0	104.7 102.4	105.0 107.0
Efficiency at 30% load (92/42/EEC Certificate: ★★★★★)		%	107.5	108.5	107.0	107.0
Instantaneous DHW production $\Delta T = 30^{\circ}\text{C}$			--	12.9	16.0	--
DHW minimum flow rate		l / min	--	2	2	--
Heat exchanger water capacity		l	2.9	3.4	3.4	3.2
Heating temperature range		$^{\circ}\text{C}$	20-80	20-80	20-80	20-80
System pressure range		bar	1-3	1-3	1-3	1-4
Supply		V / Hz	230 / 50	230 / 50	230 / 50	230 / 50
Electrical consumption		W	120	120	120	140 / 305
Gas flow rate	Natural gas LPG	m ³ /h kg/h	1.48 1.09	2.70 1.98	3.38 2.48	6.1 4.5
Weighted NO _x emissions (0% O ₂ with natural gas)		mg/kWh	25	31	24	27.9
Weighted CO emissions (0% O ₂ with natural gas)		ppm	5	20	25	15
Flue gas mass flow rate		kg/h	23.0	21.8	52.6	99
Dimensions H x W x D		mm		770 x 445 x 305		685 x 445 x 484
Empty Weight		kg	38 / 36	38 / 36 / 38	38 / 36 / 38	44 / 46

EXPERTLY ENGINEERED FOR YOU

ADVECO

EXPERTLY ENGINEERED FOR YOU

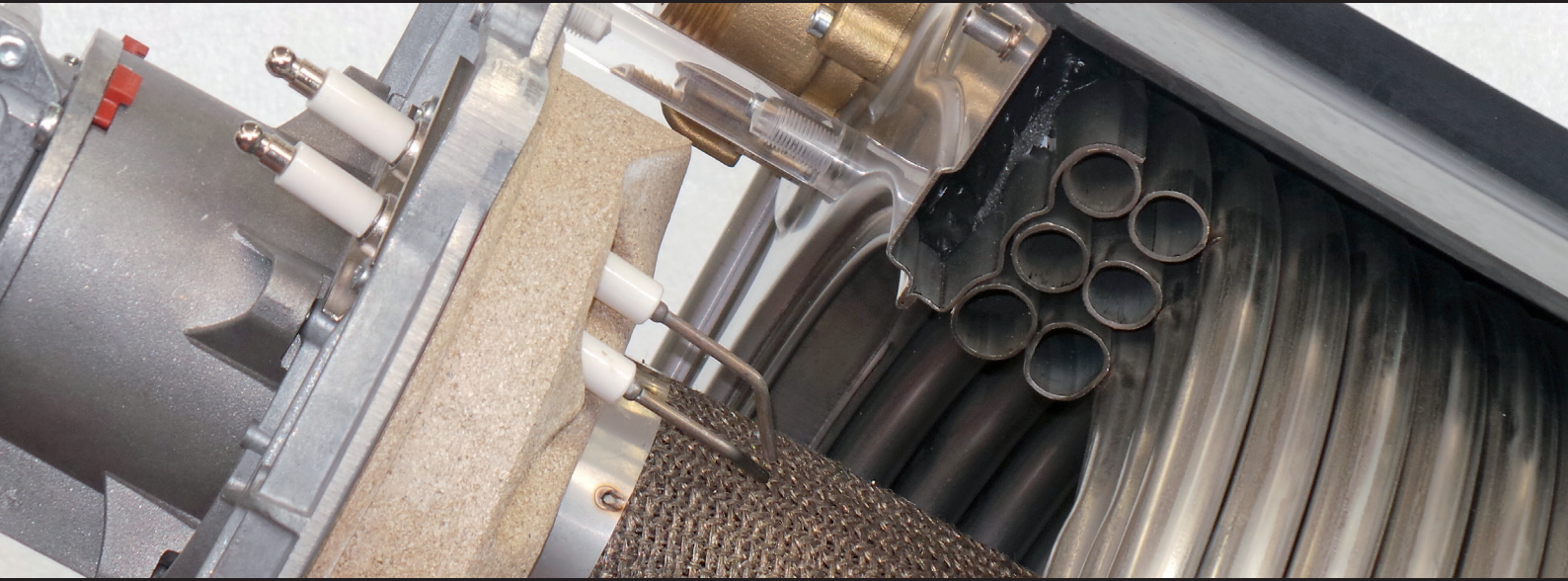

Advenco Ltd. Unit 7 & 8 Armstrong Mall, Southwood Business Park, Farnborough, Hampshire GU14 0NR
Company Reg : 09493966 T : 01252 551 540 E : enquiries@advenco.co I : www.advenco.co

SR300038.r2
ADVECO MD BOILERS PRODUCT GUIDE 2019