

EB0027 18/9kW Immersion Heater

Multi-Circuit Electric Immersion Kit for Indirect Cylinders

Installation, Operation and Maintenance Manual



Warnings

This manual should be read and understood carefully prior to installation or operation of any part of the EB0027 electric immersion heater kit. Failure to read this manual or to follow its printed instructions may lead to personal injury, damage to the immersion heater and damage to the water heating installation. These instructions should be kept in a safe and accessible place near the water heating unit.

The EB0027 immersion heater kit should be stored in a safe place prior to installation to prevent damage to the appliance or heater components. Any unused or discarded components must be disposed of in accordance with the Waste Electrical and Electronic Equipment Regulations (WEEE) 2013.

Copyright © 2016 Adveco Limited. All rights reserved.

No part of this publication may be copied, reproduced, altered and/or published by any means without the prior written approval of Adveco Limited.

Any brand names mentioned within this publication are registered trademarks of their respective owners.

Adveco Limited reserve the right to modify specifications in this manual at any time and without notification.

Adveco Limited accept no liability for third party claims arising from unauthorised use and/or use other than that as directed within this manual.



Contents	page
Product Description User	4
Instructions	
1. Responsibilities of the User	5
2. Operating Instructions	6
3. User Maintenance Requirements	7
4. Troubleshooting	7
Installation Instructions	
1. Requirements of the Installer	8
2. Requirements of the Installation	8
3. Location	9
4. Installation Procedure	10
5. Controls	11
6. Technical Details	12
7. Mechanical Connections	13
8. Electrical Connections	14
9. Commissioning Procedure	15
Maintenance Instructions	
1. Maintenance Requirements and Check Procedures	16
Contact and Warranty Information	17

User Instructions

3. User Maintenance Requirements

To ensure continued reliability and longevity of the immersion heater installation, as well as safety of users, regular maintenance should be carried out by the end user as described here.

- Isolate the mains electrical connection to the immersion heater terminal.
- Examine the immersion heater flange connection to the tank for evidence of leaks.
- Once per year confirm that the thermostats are operating correctly by turning off all other heat sources and turning on the duty immersion heater. Allow the system to heat for 1 hour per 300 litres system capacity, without hot water draw off, then confirm that the temperature at an outlet without a thermostatic mixing valve is between 55-70°C within 60 seconds.
- Draw off hot water from the tank until the water temperature is $\leq 55^{\circ}\text{C}$ and then repeat the thermostat test using the backup heating element.
- In the event of any sign of wear, damage or other faults, do not return power to the immersion heater and instead contact your service technician immediately.
- Any other maintenance tasks as defined in the risk assessment and ACOP L8, such as periodic flushing of showers and terminal outlets, plus temperature checks of taps with and without thermostatic mixing valves to assess the hot water system temperature and safety against scalding.

4. Troubleshooting

In the event of fault or failure of an immersion heater, notify the installer. All maintenance, replacement and repair inquiries should be handled by a service technician. All warranty enquiries must be administered by Adveco Ltd.

Installation Instructions

1. Requirements of the Installer/Designer

All installation work for this immersion heater kit must be carried out by an individual with the relevant qualifications and experiences to work with electrical systems and who is registered with an electrical regulatory body such as NICEIC, and should be compliant to:

- BS 7671:2008+A3:2015 IET Wiring Regulations 17th Edition.
- BS EN 806 all parts.
- BS EN 60335-2-74, IEC 60335-2-74.
- Building Regulation Part G.
- Building Standards (Scotland) Regulations.
- Health and Safety and Work Act 1974.
- Local Byelaws.

And any complementing or superseding documentation.

Adveco Limited accept no responsibility for failure to comply with the above or with safe working practices.

2. Requirements of the Installation

The Adveco EB0027 electric immersion heater kit is suitable for installation into systems with pressures up to a maximum of 6 bar and temperatures up to 90°C.

Hot water systems pose a potential risk for building occupants with regards to temperature and biological hazards. It is the responsibility of the system designer and/or installer to consider the risk to building inhabitants/end users of scalding or Legionella and put into place suitable steps to protect the occupants. This includes eliminating system deadlegs and ensuring that the hot water temperature at the furthest outlets reaches at least 50°C (55°C in healthcare premises) within 60 seconds. Guidance and information on these responsibilities can be found by referencing the following documents:

- Building Regulations Part G.
- Health and Safety at Work Act 1974.
- BS EN 806.
- ACOP L8, 2014 (4th edition).
- HSG0274 (part 2).
- HTM 04 01 part A and B.

It is very important that there is an in-depth handover process to the building controller/user so that the ongoing responsibilities of maintenance, risk assessment and system control are fully understood. The system design and intended control methods for temperature and biological hazards within the DHW system and associated building pipework should be explained to and understood by the building controller/user.



Installation Instructions

3. Location

A suitable clearance of at least 800mm should be present between the immersion heater flange and any adjacent unit or surface, in order to facilitate access for inspection, maintenance, as well as removal and/or replacement of the immersion heater. The location of the water heater should provide sufficient lighting for maintenance purposes and be in close proximity to an electrical supply. Suitable drainage should be available so that any leak from the cylinder will not risk submerging the element terminal or its electrical connections.

Immersion port clearances

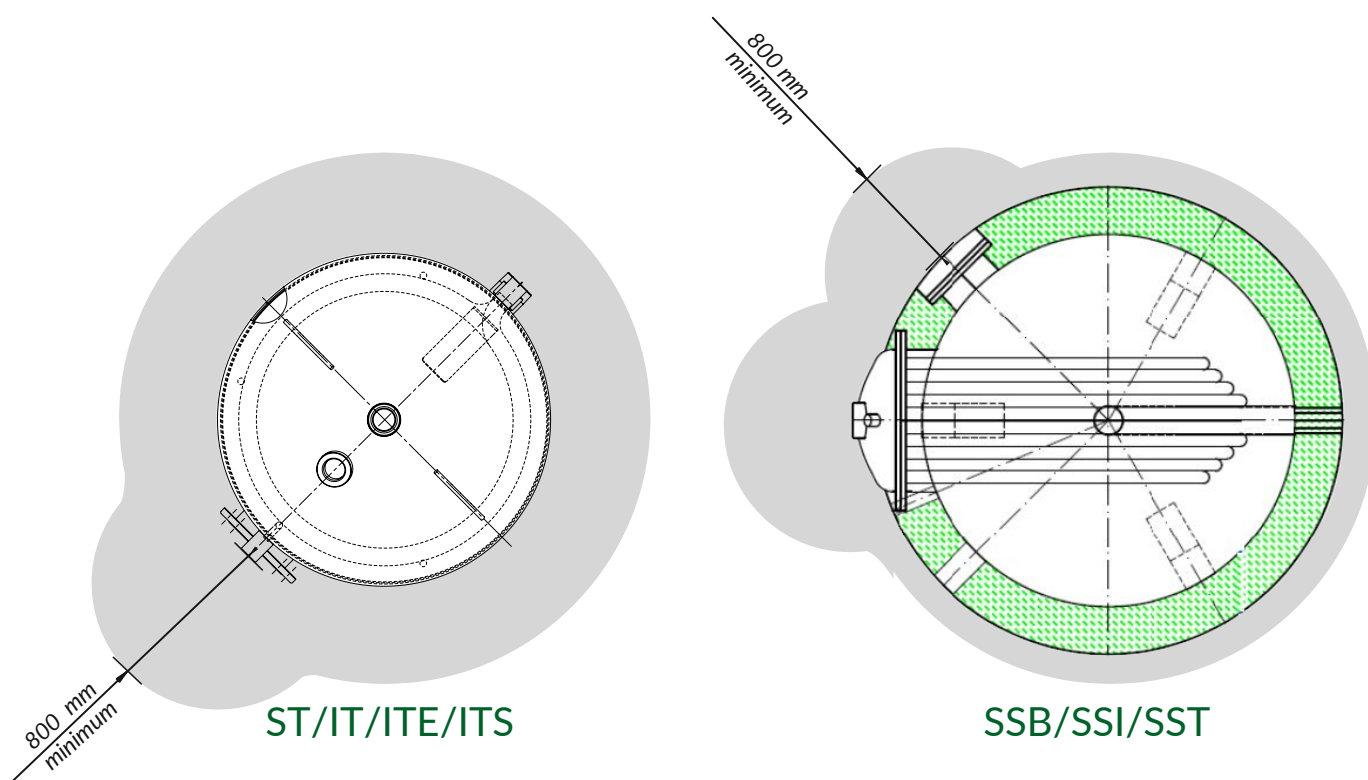

Installation Instructions

4. Installation Procedure

- Carefully remove all packaging from the immersion heater assembly and inspect the unit for any visual signs of damage.
- Ensure that the available electrical supply is three phase, 400V and matches the current rating of the immersion heater.
- Drain the vessel according to the standard procedure.
- Remove the cover, insulation, clean-out flange and gasket. The locations of these are circled in the pictures below. Store these in a safe location in case they are needed in the future.
- Insert the immersion heater into the opening, ensuring that the gasket and flange are aligned, and bolt securely to create a tight fit to the vessel. See page 13 for further details. The immersion heater is only suitable for horizontal mounting unless specified otherwise. The heater should be orientated so that the housing panel is facing down, as shown in the terminal diagram on page 13.
- Fill the system according to the standard procedure. The immersion element should be submerged at all times.
- Ensure that no air pockets remain in the system, and monitor the immersion heater flange connection for leaks.
- Set the temperature by adjusting the control thermostat dial on each circuit to be between 60-65°C.
- Ensure that the heater is isolated from the mains electricity supply before wiring.
- Drill and gland the terminal housing for cable entry points.
- Wire the terminal connections of the heater as described on page 14. The immersion heater must be wired through a four-pole rotary isolating switch and a contactor, using a cable compliant to BS EN 50525. The immersion heater must be earthed.
- Close and secure the terminal cover. The heater must be isolated from the mains prior to re-opening the cover to make any further adjustment within.



ST/IT/ITE/ITS Range



SSB/SSI/SST Range

Installation Instructions

5. Controls

For a list of components included with the EB0027, consult the kit contents on page 4.

The EB0027 has two heating circuits, however for safety it is recommended that a single isolator is used to isolate both circuits. If two separate supplies are used, a traffolyte label must be permanently fixed to the housing access door informing maintenance personnel that there are multiple points of isolation.

Each heating circuit has a separate set of temperature controls. The primary 18kW heater should be switched on with a contactor and controlled by an E0010 dual control and overheat thermostat, mounted in the hot water tank separately to and above the location of the immersion heater.

The E0010 dual thermostat features a white IP40-rated terminal box, with an adjustable control thermostat dial on its front face for simple temperature adjustment. Its over-temperature cut-out thermostat can be manually reset by unscrewing the small black cover on the front face of the E0010 terminal and pressing the button positioned beneath.

The secondary 9kW heating circuit should be switched with a contactor and controlled by an adjustable control thermostat and a fixed overheat cut-out thermostat located in the topmost pair of thermostat pockets situated inside the immersion heater terminal housing. A further two thermostat pockets are located below the elements within the terminal, and for safety reasons should be left empty and unused. Note that the terminal housing should only be opened after isolation from mains electricity. The control thermostat has an adjustable dial on its base which can be rotated to increase or decrease the heating threshold of the electrical element as desired. The overheat thermostat features a manual reset button and is factory set to 90°C.

Note that for standard installations without an alternative method of legionella protection, the control temperature on either heating circuit should not be set outside the range of 60-65°C.

When connected to a system through a control panel such as the EB0028, or to a building management system (BMS), control options may be handled by those systems directly.



Left: Image displaying the E0010 dual control and overheat thermostat for use with the primary 18kW heating circuit, showing the adjustable control temperature dial and overheat reset cover. This will be mounted on the vessel above and separate to the immersion heater terminal.



Right: Image displaying the head of the temperature control thermostat with adjustable dial, for use with the secondary 9kW heating circuit, located inside the immersion heater terminal housing. Note that the housing overheat thermostat (red) is factory set and must no adjustment must be made.

Installation Instructions

6. Technical Details

Capacity	18kW + 9kW
Supply	400V/3ph/50Hz
Wiring	L1, L2, L3, N, E
Power (18kW Circuit)	26A/phase
Power (9kW Circuit)	13A/phase
Intensity (18kW Circuit)	9.2 W/cm ²
Intensity (9kW Circuit)	12.2W/cm ²
Immersion heater part	E0048
Gasket part	E0042.1
Combined thermostat E0010:	Control range 25-65°C Overheat set point 80°C
Housing thermostats:	E0043: Control range 30-90°C E0044: Overheat set point 90°C
Suitable for use with	ST/IT/ITE/ITS 300-500, SSB/SSI/SST 500-2500
Optional ancillaries	E0049 (Auto-changeover control panel with BMS connections and heat recovery) E0028 (E0049 + SMS fault notification)



Installation Instructions

7. Mechanical Connections

The immersion heater is provided with an EPDM gasket and flange designed to fit directly into the clean-out access of the ST/IT/ITE/ITS 300-500, or SSB/SSI/SST 500-2500 range of vessels. The immersion heater can be removed for maintenance, cleaning, repair or replacement. Sealing compounds should not be applied around the flange, as upon setting they may harden and prevent removal of the heater assembly.

To secure the immersion heater into the vessel, insert it into the clean-out access and begin by hand-tightening the bolts labelled **1** & **2** on the terminal diagram below. The ring gasket can then be positioned correctly by resting it upon these two bolts, keeping it in place while the remaining bolts can be hand-tightened.

Once all bolts are loosely screwed in and the immersion heater is positioned correctly, securely tighten all the bolts in a diametrically-opposed fashion to ensure an even stress loading across the immersion heater.

Terminal Layout

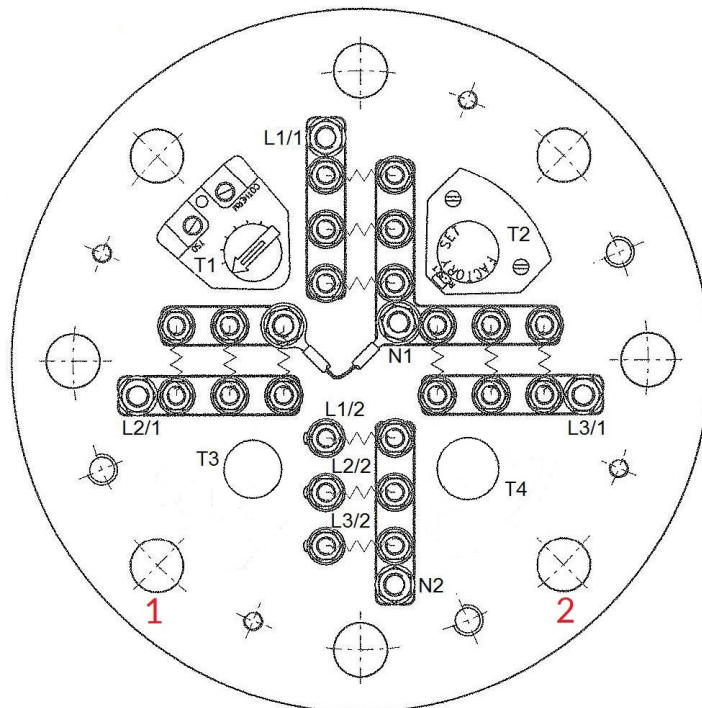

Installation Instructions

8. Electrical Connections

Consult the terminal diagram displayed on page 13 as a reference when making three phase electrical connections.

The immersion heater should be connected with fixed wiring and all cables should be correctly sized for the amperage.

Wiring Diagram

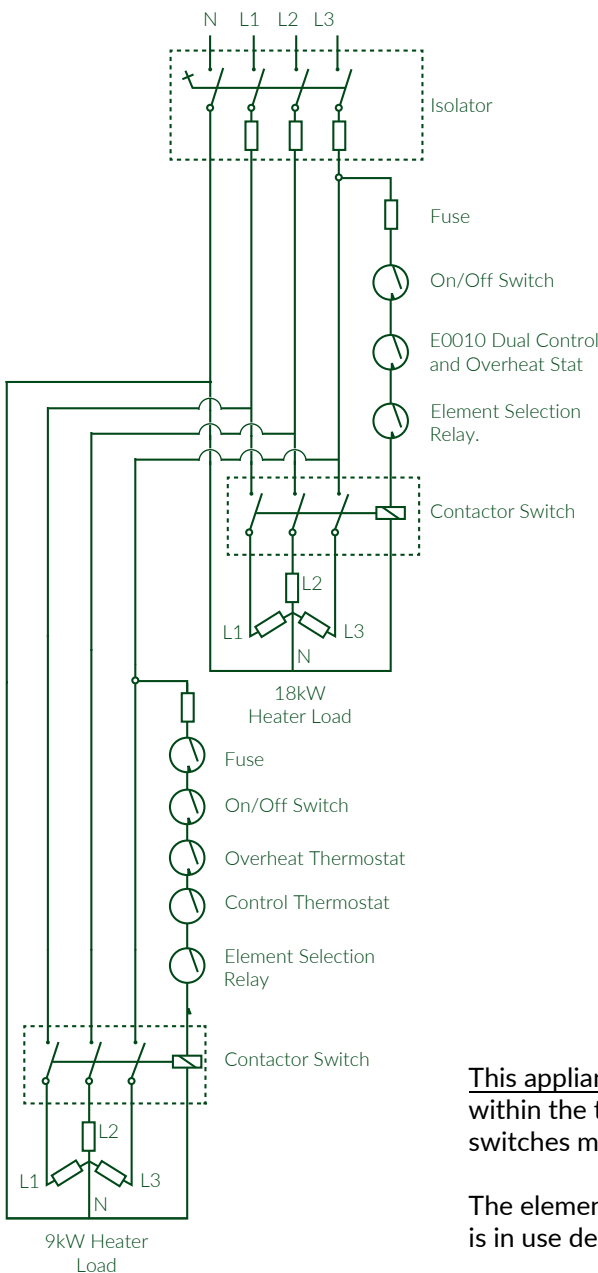

An element to thermostat direct link wire should not be used. All terminal connections must use crimp ring connections.

It is recommended that the base of the terminal should be held securely (using pliers or another appropriate tool) when tightening or loosening, to ensure that it will not shear off its connection if over-tightened.

The bottom two thermostat pockets T3 and T4 should remain empty and are not to be used for temperature control of any circuit of the EB0027. The top thermostat pockets T1 and T2 should contain one control and one overheat cut-out thermostat as provided with the immersion heater kit. These should be connected for use with the 9kW secondary heating element.

An E0010 dual control and overheat thermostat should be mounted separately on the cylinder above the level of the immersion heater and connected to the 18kW heating element.

An all pole isolator with a separation of at least 3mm must be used. Both circuits and all control wiring to thermostats must be supplied from one isolator to ensure a single point of isolation. If multiple isolators or electrical supplies are used, a traffolyte label must be permanently fixed to the housing access door informing maintenance personnel that there are multiple points of isolation.

The electrical insulation for each circuit within the immersion heater should be checked before installation. The resistance between the live and earth connections within the terminal enclosure should not fall below 1MΩ.

This appliance must be earthed. An internal earth connection is contained within the terminal box. Note that fuses, contactors, isolators and on/off switches must be supplied separately.

The element selection relay is used to determine which immersion heater is in use depending upon the control methods used with the system.



Installation Instructions

9. Commissioning Procedure

The Adveco EB0027 electric immersion heater requires commissioning following installation and prior to use by the end user. This should be carried out by a qualified installer and responsibility is held by them to ensure that the system is safe for use. Commissioning should include the following checks:

1. Ensure the integrity of all connections, including between the element, flange and water heater.
2. Ensure that all electrical connections are tight and that there is a gap of at least 5mm between any bare terminals.
3. Ensure that the control temperature setting T_{SET} of the E0010 combined thermostat is within the range of 60-65°C.
4. Ensure that the temperature setting T_{SET} of the housing control thermostat is within the range of 60-65°C.
5. Open the mains water isolation valve and allow the system to fill with water.
6. Examine connections for evidence of leaks.
7. Measure the current to each element circuit with a clamp ammeter and ensure it is within range of the technical details given on page 12.
8. Carry out a test of the E0010 combined thermostat temperature control function. Turn off all heat sources except the 18kW immersion heater, then allow a heat up period of one hour per 300 litres of system water capacity. Confirm that the temperature reaches and does not exceed the control thermostat setting.
9. Carry out a test of the immersion-housing control thermostat. Draw off hot water from the tank until the water temperature is $\leq 55^{\circ}\text{C}$ and then turn on the 9kW immersion heater alone. Allow a short heat up period and then confirm that the tank has come up to but does not exceed the terminal control thermostat temperature setting.
10. Test the calibration of the overheat cut-out thermostats.
11. Hand over responsibility of the system to the building controller/user. Include a thorough explanation of the ongoing responsibilities of maintenance, risk assessment, and system control. Ensure that the building controller/user fully understands the system design as well as the temperature and biological hazard control methods used in the DHW system and associated building pipework.
12. Provide this document to the building controller/user alongside the commissioning report.

Maintenance Instructions

1. Maintenance Requirements and Check Procedures

At minimum, the immersion heater should be serviced annually by a qualified engineer. An initial check should be carried out three months after installation, and the subsequent maintenance demand should be determined based on the level of scale build up. The unit must be fully isolated from the mains electricity supply prior to any inspection or maintenance work being carried out. The maintenance procedure should include at least the following checks:

- Inspect the mounted element and its physical connection for evidence of any damage or leaks.
- Ensure that the terminal box is intact and its internal area is dry.
- Ensure that all electrical connections are secure and show no signs of wear.
- Drain the tank according to its standard procedure and remove the immersion heater. Check for visual wear on the gasket. Replacement of the gasket should be considered.
- Examine the heater elements and thermostat pockets for visual signs of wear or build-up of scale deposits. Descale if necessary.
- Inspect the tank flange and ensure that the interior of the tank does not contain scale deposits. Clean out any scale that is found.
- Re-insert the heater assembly, secure and re-fill the tank according to the standard procedure.
- Examine the flange connection and ensure no leaks are present.
- Test the electrical insulation between the live and earth terminals and ensure the resistance is at least 1MΩ.
- Test the amperage through each phase and confirm it is in line with the technical details given on page 12. As the element ages it is likely that individual rods will begin to fail. It is only necessary to replace the immersion heater when it can no longer meet the DHW requirements of the building or the phase loading becomes too imbalanced.
- Carry out a test of the E0010 combined thermostat temperature control function. Turn off all heat sources except the 18kW immersion heater, then allow a heat up period of one hour per 300 litres of system water capacity. Confirm that the temperature reaches and does not exceed the control thermostat setting.
- Carry out a test of the immersion-housing control thermostat. Draw off hot water from the tank until the water temperature is $\leq 55^{\circ}\text{C}$ and then turn on the 9kW immersion heater alone. Allow a short heat up period and then confirm that the tank has come up to but does not exceed the terminal control thermostat temperature setting.

Contact and Warranty Information

The EB0027 Immersion Heater Kit, this manual and all information contained within are supplied by Adveco Ltd.

Adveco Ltd.
Unit 7&8 Armstrong Mall,
Southwood Business Park,
Farnborough,
Hampshire,
GU14 0NR
T: 01252 551 540
info@adveco.co
www.adveco.co

Adveco Ltd. are the point of contact for all warranty claims and queries through the above address.

Disposal of any part of the EB0027 Immersion Heater Kit must be carried out in accordance with the Waste Electrical and Electronic Equipment Regulations (WEEE) 2013. The system must be decommissioned by a qualified engineer prior to any equipment disposal.

Advenco also offer the following products and services:

- Bespoke system design
 - Maintenance and service packages
 - Buffer tanks
 - Indirect and direct hot water systems
 - Off-site manufacturing of skids and plant rooms
 - Controls systems
 - Packaged plate heat exchangers
 - Solar thermal systems
 - Gas fired heating systems
 - Combined heat & power cogeneration systems
-



Advenco Ltd

Unit 7&8 Armstrong Mall, Southwood Business Park Farnborough, Hampshire GU14 0NR
T : 01252 551 540

info@advenco.co

www.advenco.co

