

# Advenco AD16, AD22, AD37

## Wall-Mounted Condensing Instantaneous Water Heater



The Advenco AD range of high efficiency wall-mounted condensing gas-fired water heaters is designed to provide a compact, high capacity and reliable method for delivering instantaneous hot water to a building.

The wall-mounted AD water heater is available in three rated heat outputs, 27 kW (AD16), 33 kW (AD22) and 61 kW (AD37). The AD range are 'A' class energy efficient water heaters, with a net efficiency of up to 107% for the production of domestic hot water (DHW).

The water heater features a single high quality patented heat exchanger constructed from a continuous, non-welded run of titanium-stabilised stainless steel, providing exceptional construction strength and corrosion resistance. The brand-exclusive three pass design features large bore, circular tube cross sections that reduce the collection of debris.

With an efficient pre-mix burner and minimal NO<sub>x</sub> and CO emissions, the AD range is an eco-friendly way to serve a domestic hot water system. The unit additionally features a high 1:8 modulation ratio to ensure maximum efficiency even during periods of low demand.

Also included is an inbuilt controller with LCD display that ensures full temperature control and a maintenance self-check of primary components and functions.

### STANDARD FEATURES

- Extremely high quality AISI 316Ti heat exchangers with 5 year warranty ensures lasting reliability and efficiency
- High efficiency pre-mix burner with 5 year warranty provides large modulation range
- Compact wall-hung arrangement
- Ultra-low NO<sub>x</sub> emissions at 16-29 mg/kWh
- Available using natural gas or LPG
- Supports standard concentric or parallel flue systems using adaptor for low cost 80/125 mm diameter PP available on request
- Integrated run/fault signal for connection to BMS



- 1 3/4" recirculation
  - 2 1" DHW outlet
  - 3 3/4" gas inlet
  - 4 Cold water inlet  
3/4" (16-22 Models) / 1" (37 Model)
  - 5 Flue outlet / Air intake  
2 x 80 mm parallel (16 -22- 37 Models)  
60/100 mm concentric (16-22 Models)  
80/125 mm concentric (37 Models)
  - 6 Support mounts
  - 7 Ø20 condensate discharge
- A 305 mm (16-22 Models) / 484 mm (37 Model)
  - B 120 mm (16-22 Models) / 175 mm (37 Model)
  - C 125 mm (16-22 Models) / 205 mm (37 Model)

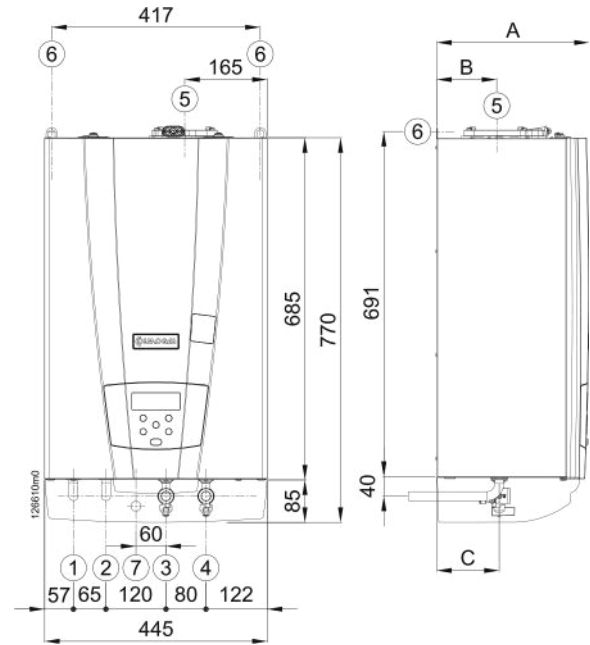

### Technical Specifications

### Units AD16 AD22 AD37

		Units	AD16	AD22	AD37
Heat input range	Maximum	kW	28.3	35.5	64.2
	Minimum		3.6	6.7	13.3
Heat output range	Maximum	kW	27.0	33.5	60.9
	Minimum		3.0	6.1	12.8
Net efficiency	At maximum output	%	105.7	104.7	105.3
	At minimum output		103.0	102.4	107.1
Energy efficiency class			A	A	A
Declared load profile			XL	XXL	XXL
Continuous DHW production (ΔT 50°C)		l/min.	7.7	9.6	17.5
Gas flow rate	Methane	m <sup>3</sup> /h	2.7	3.4	6.1
	LPG	kg/h	2.0	2.5	4.5
Gas supply pressure	Methane	mbar	20	20	20
	LPG		37	37	37
Minimum water flow rate		l/min	2.5	2.5	2.5
Working pressure range	Maximum	bar	9.5	9.5	9.5
	Minimum		1.0	1.0	1.0
Working temperature range	Maximum	°C	75	75	75
	Minimum		40	40	40
Water hardness	Maximum	ppm CaCO <sub>3</sub>	150	150	150
Power supply		V / Hz	230 / 50	230 / 50	230 / 50
Total absorbed power		W	165	165	235
Weighted CO (0% O <sub>2</sub> with methane)		ppm	11	19	10
Weighted NO <sub>x</sub> (0% O <sub>2</sub> with methane)		mg/kWh	20	29	16
Dimensions H × W × D		mm	685 × 445 × 305	685 × 445 × 305	685 × 445 × 484
Maximum flue run Less 0.5m per 45° bend, Less 1.0m per 90° bend	Concentric	m	10.0	10.0	10.0
	Parallel		20.0	12.5	10.0
Indoor sound power level		dB	51	52	58
Empty weight		kg	36	36	48

# Ancillaries & Flue Components



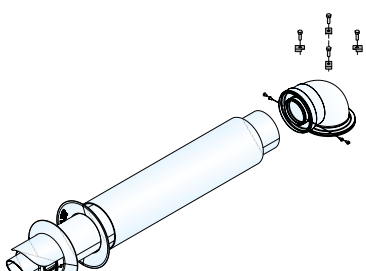
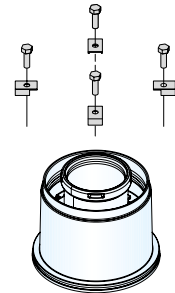
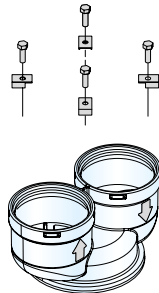

For further information and specifications on the full range of available flues and ancillaries, please contact the Advenco application design department at [technical@advenco.co](mailto:technical@advenco.co) or 01252 551 540 Option 5.

All drawings displayed below are for representative purposes only and actual products may differ.

Each water heater must be equipped with one of the following kits

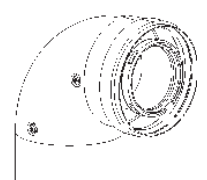
1	2	3
<p><b>Horizontal Coaxial Vent Kit</b></p>  <p>AD16-AD22 - Ø60/100 Code: 62617228 AD37 - Ø80/125 Code: N/a</p> <p>90° Concentric flue adapter and horizontal terminal for combined air intake and flue gas outlet. Enamelled steel outside, PP inside.</p>	<p><b>Vertical Coaxial Adaptor</b></p>  <p>AD16-AD22 - Ø60/100 Code: 62617224 AD37 - Ø80/125 Code: 62617314</p> <p>Concentric vertical flue adapter for combined air intake and flue gas outlet. 62617224: Enamelled steel outside, PP inside. 62617314: Aluminium outside, PP inside.</p>	<p><b>Split System Vent Adaptor</b></p>  <p>AD16-AD22 - 2× Ø80 Code: 62617226 AD37 - 2× Ø80 Code: 62617315</p> <p>Parallel PP flue adapter for separated air intake and flue gas outlet. 62617315: Aluminium outside, PP inside.</p>

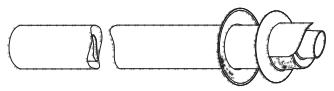
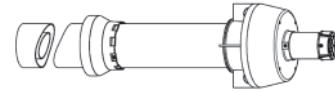
## Additional flue components and ancillaries

<p><b>Flue Concentric Elbow - 90°</b></p>  <p>AD16-AD22 - Ø60/100 Code: 62617234 AD37 - Ø80/125 Code: 62617321</p> <p>Male to female 90° concentric flue elbow. 62617324: Enamelled steel outside, PP inside. 62617321: Aluminium outside, PP inside.</p>	<p><b>Flue Concentric Elbow - 45°</b></p>  <p>AD16-AD22 - Ø60/100 Code: 62617252 AD37 - Ø80/125 Code: 62617322</p> <p>Male to female 45° concentric flue elbow. 62617252: Enamelled steel outside, PP inside. 62617322: Aluminium outside, PP inside.</p>	<p><b>Flue Concentric 1m Extension</b></p>  <p>AD16-AD22 - Ø60/100 Code: 62617231 AD37 - Ø80/125 Code: 62617323</p> <p>One metre concentric flue extension. Enamelled steel outside, PP inside.</p>
<p><b>Flue Concentric Horizontal Terminal</b></p>  <p>AD16-AD22 - Ø60/100 Code: 62617232 AD37 - Ø80/125 Code: 62617324</p> <p>Concentric flue wall hung horizontal terminal, one metre length. 62617232: Enamelled steel outside, PP inside. Included with kit 62617228. 62717324: Aluminium outside, PP inside.</p>	<p><b>Flue Concentric Vertical Terminal</b></p>  <p>AD16-AD22 - Ø60/100 Code: 62617304 AD37 - Ø80/125 Code: 62617325</p> <p>Concentric flue vertical terminal. one metre length. PP inside and outside.</p>	<p><b>Roof Flashing 18-44°</b></p>  <p>All Models Ø60/100-Ø80/125 Code: 62617255</p> <p>Roof flashing for vertical terminal. Suitable for sloped pitch of 18-44°.</p>