

ATSB, ATSI, ATST, ATSH, ATSR

Adveco Stainless Steel Hot Water Tanks

Installation, Operation, and Maintenance Manual



Warnings

This manual should be read and understood prior to installation or operation of any Adveco ATSB, ATSI, ATST, ATSH or ATSR hot water tank. Failure to read this manual or follow its printed instructions may lead to personal injury, damage to the vessel and damage to the water heating installation. These instructions should be kept in a safe and accessible place near the vessel.

Vessels should be stored in a safe place prior to installation to prevent damage.

Copyright © 2025 Adveco Ltd. All rights reserved.

No part of this publication may be copied, reproduced, altered and/or published by any means without the prior written approval of Adveco Ltd.

Any brand names mentioned within this publication are registered trademarks of their respective owners.

Adveco Ltd. reserves the right to modify specifications in this manual at any time and without notification.

Adveco Ltd. accepts no liability for third party claims arising from unauthorised use and/or use other than as directed within this manual.

How to Use This Manual

All general information, instructions and specifications listed within this manual applies to the full range of ATSB, ATSI, ATST, ATSH, and ATSR (hereafter collectively "ATSx") tanks. Any information relevant to only specific tank ranges is contained within dedicated sections and is clearly identifiable by section titles.

All information unless otherwise stated is applicable to installations in any country. Any information that is relevant to a particular country only is separated and located within clearly marked sections.

For any queries or issues not covered by the scope of this manual, please contact the Adveco Technical Department using the contact details provided on page 21.

Contents

	Page
Product Description	4
Installation Instructions	5
1. Responsibilities of the User	5
2. Responsibilities of the Installer / Designer	6
3. Requirements of the Installation	6
4. Location & Handling	6
5. Connections and Dimensions: ATSB	7
6. Connections and Dimensions: ATSI	8
7. Connections and Dimensions: ATST	9
8. Connections and Dimensions: ATSH	10
9. Connections and Dimensions: ATSR	11
10. Primary Pipework	12
11. Secondary Pipework	13
12. Discharge Pipework	14
13. Secondary Return Pipework	15
14. Shunt / Destratification Pump	15
15. Multiple Tanks	16
16. Controls	17
Maintenance Operations	18
Technical Specifications	19
Contact Details & Warranty Information	21
Appendix A: Product Fiche	

Product Description

Adveco ATSt Stainless Steel Hot Water Tanks

The Adveco ATSt tanks are a versatile range of stainless steel domestic hot water storage vessels and calorifiers that can be supplied with up to two indirect heating coils as required by the application. The range is divided into five types of vessel depending on the number and type of internal heat exchange coils included:

ATSB tanks are supplied as hot water storage tanks, and do not include internal heat exchange coils, to serve as buffer vessels only.

ATSI tanks are supplied with a single fixed internal heat exchange coil positioned in the lower half of the tank, designed to serve as an indirect water heater in conjunction with an external heat source.

ATST tanks are supplied with two fixed internal heat exchange coils that can either operate independently or be connected together to serve a single high-capacity heat source.

ATSH tanks are supplied with a single fixed high capacity internal heat exchanger coil positioned in the lower half of the tank, designed to serve as a high power indirect water heater in conjunction with one or more large heat sources.

ATSR tanks are supplied with two fixed internal heat exchange coils specially designed for use with renewable heat sources such as, but not limited to, solar thermal systems and heat pumps.

The Adveco ATSB, ATSI, ATST, ATSH and ATSR ranges are designed, manufactured, and tested in the EU to the requirements of:

The Pressure Equipment Directive EN 12897:2016

The scope of EN 12897:2016 covers indirectly heated, mains pressure storage water heaters, with or without immersion heater backup, up to 1000 litres and 10 bar. The ATSB, ATSI, ATST, ATSH and ATSR ranges have been produced to the requirements of this standard.

Installation Instructions

1. Responsibilities of the User

Hot water systems pose a potential risk for building occupants regarding temperature and biological risks. It is the responsibility of the building controller to assess the risk to the occupants of scalding or Legionella and put in place suitable steps to protect the occupants.

The risk assessment must be carried out by someone suitably qualified. The following documents offer guidance and assistance on responsibilities:

ACOP L8, 2014
HSG274 Part 2
Health and Safety at Work Act
Workplace (Health, Safety and Welfare) Regulations
HTM 04 01 Part A and B
Building Regulations Part G
BS EN 806 All parts
CEN/TR 16355

And any other standards, laws, guidelines, or rules in force in the location of the installation, past or future, that are current at the time of installation. This installation manual complements these rules and must not be considered to override them in any way.

Following the commissioning of a system and in compliance with the procedures and advice contained within this manual, responsibility lies with the building controller to maintain a safe standard of operation and regular maintenance procedures as required by the risk assessment. This includes ensuring that the unit is not operated at temperatures or pressures in excess of those stated on the vessel data plate. Nor should the vessel be exposed to a full or partial vacuum, such as can be present during draw-off or drainage of the unit while the cold feed or vent are closed or obstructed.

Failure to maintain a minimum of annual maintenance may void any and all warranties. Full maintenance procedures should only be carried out by a suitably qualified person. Basic maintenance regimes, as determined through risk assessment, should be carried out by the user as directed on page 18.

Adveco Ltd. advise that heating systems in unoccupied premises, or that are subjected to long periods of shutdown, should be drained down according to the procedure on page 18, to remove the risk of failure and/or damage occurring while the system is not being monitored.

Installation Instructions

2. Responsibilities of the Installer / Designer

In compliance with the procedures and advice contained within this manual, responsibility lies with the installer to ensure that the vessels are correctly and safely installed in line with all local regulations and laws. In all cases, the relevant laws and regulations take precedence over the instructions contained within this manual.

3. Requirements of the Installation

Any unvented cylinder installation should be notified to Building Control. This is best done through a Competent Persons Scheme by installers holding a valid unvented domestic hot water ticket.

The following documents set out the standards of installation that must be adhered to:

EN 806 All Parts
EN 8558:2015

The ATSB, ATSI, ATST, ATSH, and ATSR ranges of hot water tanks from are suitable for use with storage or heating of potable water in installations up to a maximum pressure of 10 bar.

4. Location & Handling

Suitable methods of moving a vessel include the use of a forklift truck where the vessel is securely fixed to a pallet capable of supporting its weight, or by boom crane using adequate textile slings of suitable capacity to lift the weight of the tank. Vessels should not be lifted using the insulation, by chains, or by straps that may damage the insulation, connections, or walls of the tank. Care should be taken when moving or lifting to minimise the risk of damage to the vessel.

The vessel must be located inside the building and positioned on a level base capable of supporting the unit when full. Floor loading calculations should include the total filled weight, being equivalent to the sum of the empty weight of the vessel and the weight of any installed pipework or fittings, plus the water volume in litres (where 1 litre of water weighs 1 kg). For tank dry masses, please consult pages 19-20.

The vessel should be positioned to provide suitable clearances to permit access for visual inspection and maintenance of all connections and fittings. Advenco recommend a clearance of at least 500mm on all sides of the vessel, and 1m in front of the vessel clean-out flange. Consideration should be given to the inspection, removal and replacement of any flanges, ancillaries, thermostats, and safety valves present, as well as replacement of the entire vessel.

Any water storage vessel requires some provision against damage to surrounding infrastructure, electronics, and equipment in the event of a leak, damage, or vessel failure. Acceptable methods of protection include suitable bunding, gulley, drainage, or a leak detection and warning system.

All tanks are supplied pre-fitted with insulation jackets of Neodul® thermal insulation with a simple clasp fitting which allows simple and fast removal. Jackets may be removed for the purposes of manoeuvring vessels into location or for access through narrow entry points, however must be replaced and secured before the cylinders are piped up.

Installation Instructions

5. Dimensions and Connections: ATSB

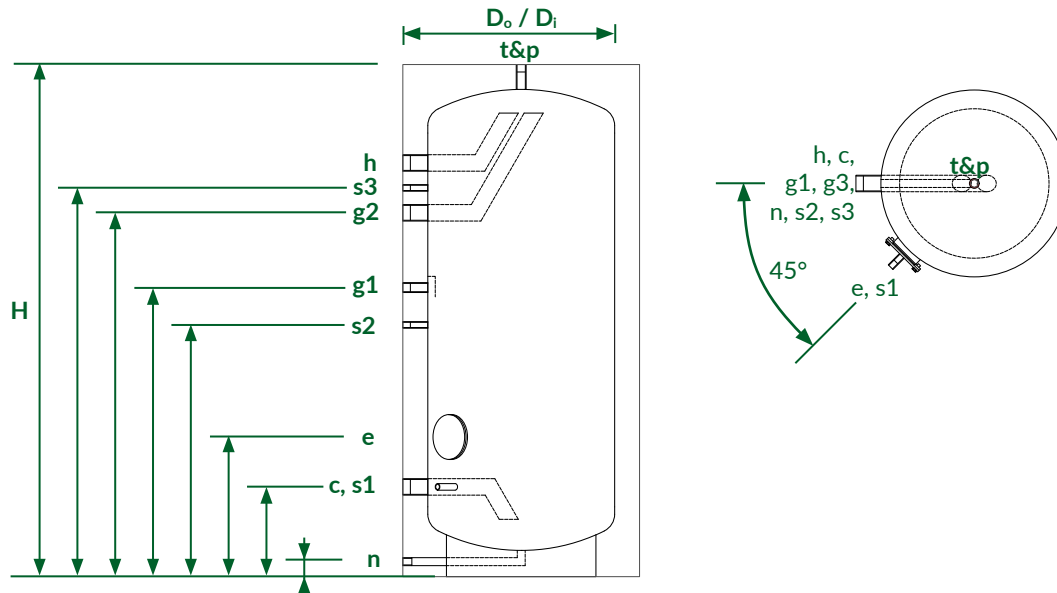

Connections

Label	Description	200	300	400	500	580	750	1000
c	Cold water inlet / external heat exchanger return	1¼"	1¼"	1½"	1½"	1½"	2"	2"
h	Hot water outlet	1¼"	1¼"	1½"	1½"	1½"	2"	2"
f	Connection for external heat exchanger flow	1¼"	1¼"	1½"	1½"	1½"	2"	2"
y	Secondary return	1"	1"	1"	1"	1"	1"	1"
t&p	T&P relief valve connection	¾"	¾"	¾"	¾"	¾"	¾"	¾"
s1, s2, s3	Sensor pockets	¾"	¾"	¾"	¾"	¾"	¾"	¾"
e	Clean-out flange (mm)	Ø180/120	Ø180/120	Ø180/120	Ø180/120	Ø180/120	Ø180/120	Ø180/120
n	Drain	¾"	¾"	¾"	¾"	¾"	¾"	¾"

Dimensions

Label	Description	200	300	400	500	580	750	1000
H	Height	1485	1735	1725	1975	1985	2055	2045
-	Tilted height	1520	1765	1755	2005	2020	2100	2090
-	Height incl. insulation	1485	1735	1725	1975	1985	2055	2045
D _o	Outer diameter including insulation	Ø700	Ø700	Ø800	Ø800	Ø850	Ø950	Ø1050
D _i	Inner diameter	Ø500	Ø500	Ø600	Ø600	Ø650	Ø750	Ø850
c	Cold water inlet / external heat exchanger return	295	295	320	320	320	360	355
h	Hot water outlet	1125	1375	1390	1610	1610	1660	1655
f	Connection for external heat exchanger flow	945	1195	1190	1410	1410	1460	1455
y	Secondary return	845	985	1010	1110	1110	1160	1155
s1	Sensor pocket	295	295	320	320	320	360	355
s2	Sensor pocket	745	885	910	960	960	1010	1005
s3	Sensor pocket	1035	1285	1290	1510	1510	1560	1555
e	Flange centre point	460	460	520	520	520	560	555
n	Drain	60	60	60	60	60	60	60

All threaded connections are Rp female unless otherwise stated. All dimensions in mm.

Installation Instructions

6. Dimensions and Connections: ATSI

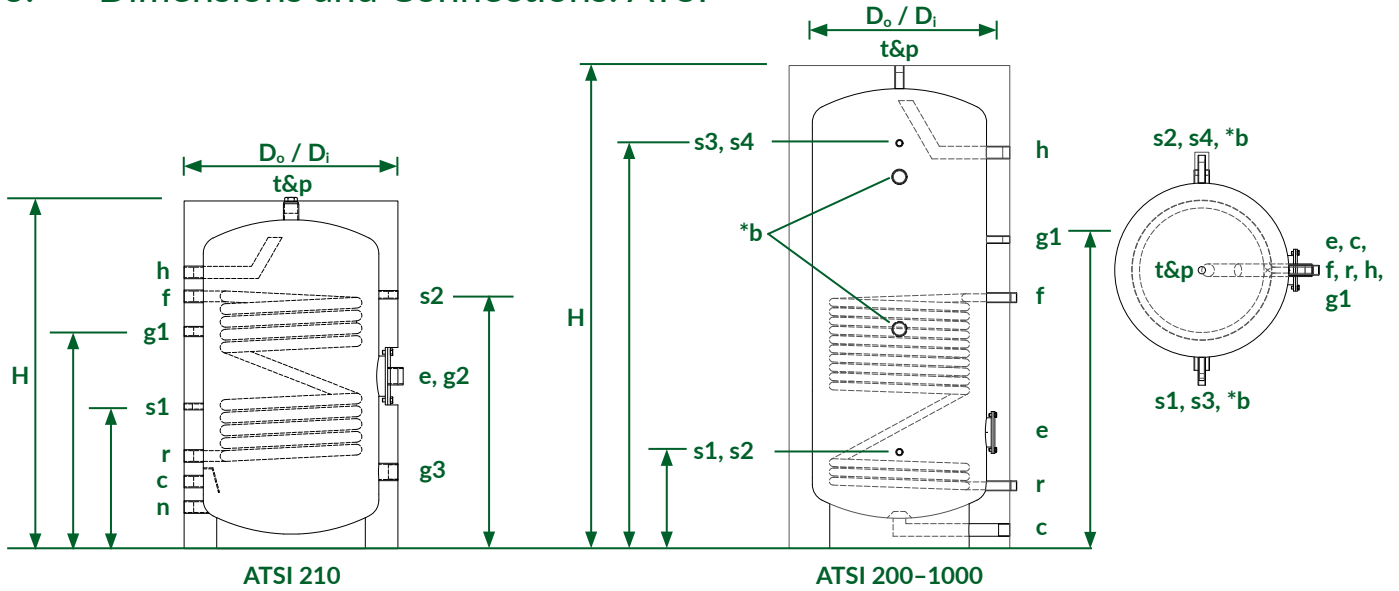

Connections

Label	Description	200	210	300	400	500	580	750	1000
c	Cold water inlet	¾"	1"	1"	1"	1"	1"	1½"	2"
h	Hot water outlet	¾"	1"	1"	1"	1"	1"	1½"	2"
f, r	Heat exchanger flow and return	1"	1"	1"	1"	1"	1"	1¼"	1¼"
g1 g2, g3	Additional connection(s) (g2 and g3 only on ATSI 210)	½"	¾"	¾"	¾"	¾"	¾"	¾"	1"
t&p	T&P relief valve connection	1"	1¼"	1"	1"	1"	1"	1"	1"
s1, s2, s3, s4	Sensor pockets	¾"	½"	¾"	¾"	¾"	¾"	¾"	¾"
e	Clean-out flange (mm)	Ø180/120	Ø180/120	Ø180/120	Ø180/120	Ø180/120	Ø180/120	Ø180/120	Ø180/120
n	Drain connection	--	1"	--	--	--	--	--	--

All threaded connections are Rp female unless otherwise stated. Coil connections R. All dimensions in mm.
*b: Left and right side 2" mounting brackets included on models 300-1000 only.

Dimensions

Label	Description	200	210	300	400	500	580	750	1000
H	Height	1480	1100	1740	1735	1990	1990	2080	2080
-	Tilted height	1530	1150	1790	1790	2040	2045	2140	2140
-	Height including insulation	1480	1100	1740	1735	1990	1990	2080	2080
D _o	Outer diameter Including insulation	Ø700	Ø750	Ø700	Ø800	Ø800	Ø850	Ø950	Ø1050
D _i	Inner diameter	Ø500	Ø550	Ø500	Ø600	Ø600	Ø650	Ø750	Ø850
c	Cold water inlet	60	210	65	65	65	65	80	80
h	Hot water outlet	1135	865	1395	1240	1670	1670	1705	1705
f	Flow from heat source	690	790	880	875	1120	1085	1080	855
r	Return to heat source	180	290	190	215	215	215	270	265
y	Secondary return	960	680	1120	1060	1305	1305	1330	1330
s1, s2	Sensor pockets (2x)	430	445	380	405	545	405	415	555
s3, s4	Sensor pockets (2x)	1180	795	1415	1440	1695	1690	1745	1745
e	Flange centre point	450	540	400	425	500	500	500	595

Installation Instructions

7. Dimensions and Connections: ATST

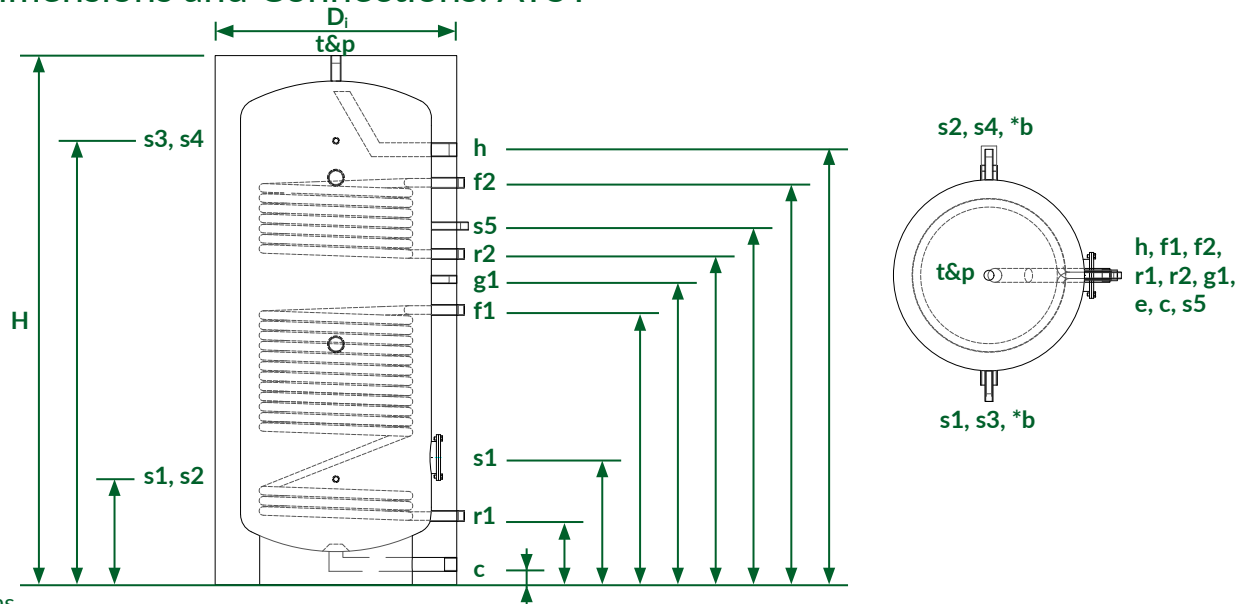

Connections

Label	Description	200	300	400	500	580	750	1000
c	Cold water inlet	1"	1"	1"	1"	1½"	1½"	2"
h	Hot water outlet	1"	1"	1"	1"	1½"	1½"	2"
f1, f2 r1, r2	Heat exchangers flow and return	1"	1"	1"	1"	1"	1¼"	1¼"
g1	Additional connection	¾"	¾"	¾"	¾"	¾"	¾"	1"
t&p	T&P relief valve connection	¾"	¾"	¾"	¾"	¾"	¾"	¾"
s1, s2, s3, s4, s5	Sensor pockets	¾"	¾"	¾"	¾"	¾"	¾"	¾"
e	Clean-out flange (mm)	Ø180/120	Ø180/120	Ø180/120	Ø180/120	Ø180/120	Ø180/120	Ø180/120

All threaded connections are Rp female unless otherwise stated. Coil connections R. All dimensions in mm.

Dimensions

Label	Description	200	300	400	500	580	750	1000
H	Height	1340	1590	1635	1890	1890	1980	1980
-	Tilted height	1380	1625	1680	1920	1930	2035	2045
-	Height including insulation	1390	1740	1735	1990	1990	2080	2080
Do	Outer diameter Including insulation	Ø700	Ø700	Ø800	Ø800	Ø850	Ø950	Ø1050
Di	Inner diameter	Ø500	Ø500	Ø600	Ø600	Ø650	Ø750	Ø850
c	Cold water inlet	65	65	65	65	65	80	80
h	Hot water outlet	1140	1410	1425	1670	1660	1710	1705
f1	Flow from heat source (lower)	700	830	845	995	1085	1080	855
r1	Return to heat source (lower)	190	190	215	215	215	505	265
f2	Flow from heat source (upper)	1060	1310	1320	1560	1555	1580	1375
r2	Return to heat source (upper)	860	1020	1065	1200	1295	1300	1095
g1	Additional connection	775	925	960	1100	1190	1200	975
s1, s2	Sensor pockets (2x)	405	380	405	455	390	505	505
s3, s4	Sensor pockets (2x)	935	1130	1150	1320	1390	1410	1200
s5	Sensor pocket	1155	1415	1440	1690	1665	1745	1745
e	Flange centre point	440	440	465	515	465	565	565

Installation Instructions

8. Dimensions and Connections: ATSH

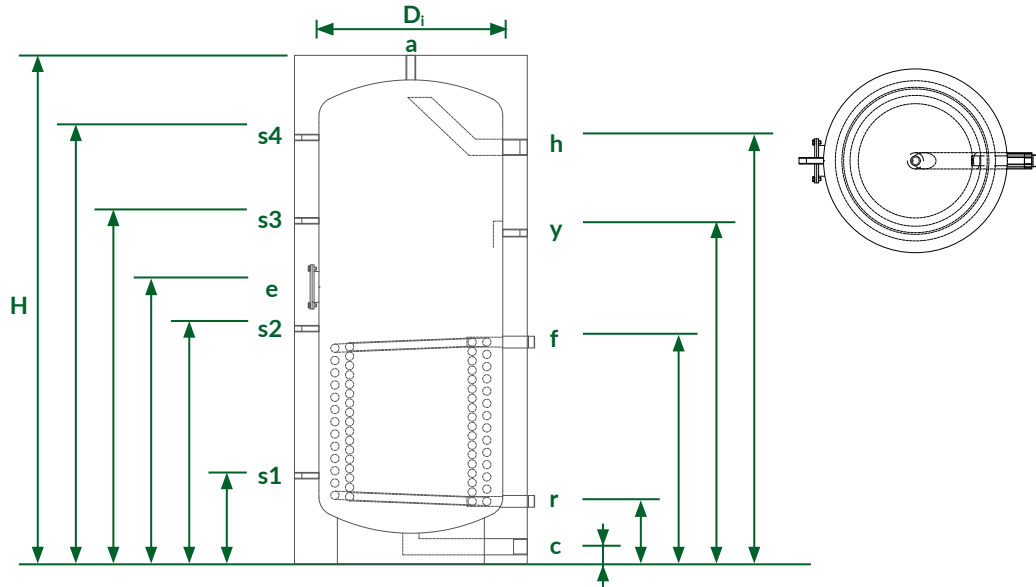

Connections

Label	Description	200	300	400	500	750	1000
c	Cold water inlet	1"	1"	1½"	1½"	2"	2"
h	Hot water outlet	1"	1"	1½"	1½"	2"	2"
f, r	Heat exchanger flow and return	1"	1"	1"	1"	1½"	1½"
r	Return to heat source	1"	1"	1"	1"	1½"	1½"
y	Secondary return	¾"	¾"	¾"	¾"	¾"	¾"
t&p	T&P relief valve connection	1"	1"	1"	1"	1"	1"
s1, s2, 3, s4	Sensor pockets	¾"	¾"	¾"	¾"	¾"	¾"
e	Clean-out flange (mm)	Ø180/120	Ø180/120	Ø180/120	Ø180/120	Ø180/120	Ø180/120

All threaded connections are Rp female unless otherwise stated. Coil connections R. All dimensions in mm.

Dimensions

Label	Description	200	300	400	500	750	1000
H	Height	1340	1590	1635	1885	1975	1975
-	Tilted height	1395	1645	1690	1940	2040	2050
-	Height including insulation	1490	1740	1735	1985	2075	2075
Do	Outer diameter including insulation	Ø700	Ø700	Ø800	Ø800	Ø950	Ø1050
Di	Inner diameter	Ø500	Ø500	Ø600	Ø600	Ø750	Ø850
c	Cold water inlet	70	70	70	70	70	70
h	Hot water outlet	1145	1395	1420	1670	1700	1700
f	Flow from heat source	585	775	830	885	905	905
r	Return to heat source	195	195	215	215	255	255
y	Secondary return	880	1180	1150	1400	1350	1350
s1	Sensor pocket	285	285	310	310	360	360
s2	Sensor pocket	650	815	895	950	960	960
s3	Sensor pocket	950	1240	1200	1490	1400	1400
s4	Sensor pocket	1165	1415	1440	1690	1740	1740
e	Flange centre point	800	975	1035	1090	1130	1130

Installation Instructions

9. Dimensions and Connections: ATSR

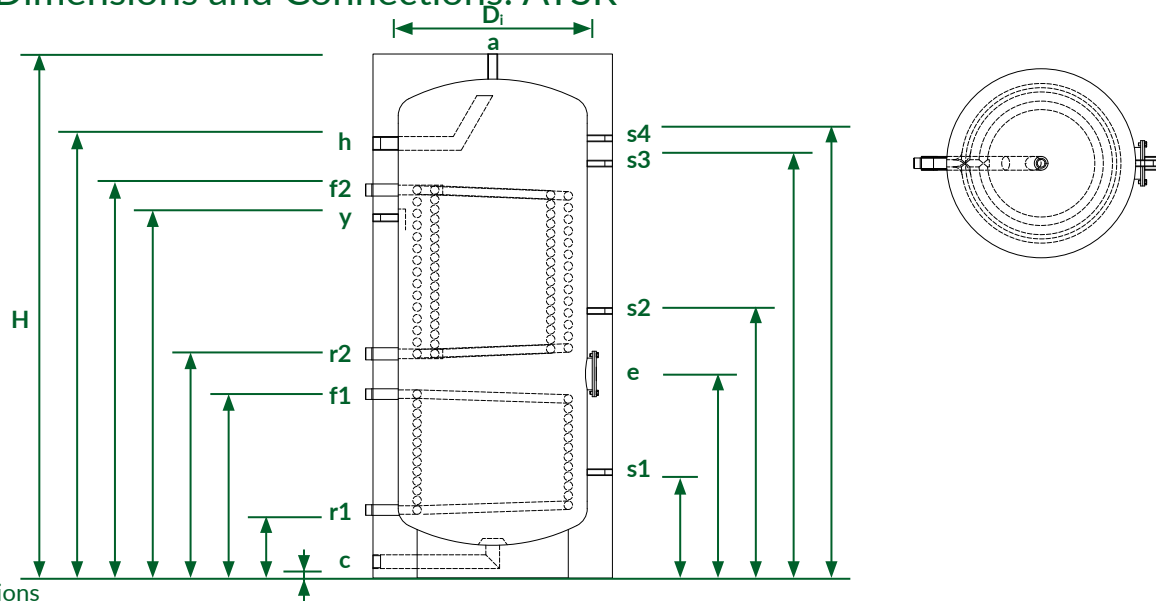

Connections

Label	Description	300	400	500	750	1000
c	Cold water inlet	1½"	1½"	1½"	1½"	2"
h	Hot water outlet	1½"	1½"	1½"	1½"	2"
f1, r1	Lower heat exchanger flow and return	1½"	1½"	1½"	1½"	1½"
f2, r2	Upper heat exchanger flow and return	1"	1"	1½"	1½"	1½"
y	Secondary return	¾"	¾"	¾"	¾"	¾"
t&p	T&P relief valve connection	1"	1"	1"	1"	1"
s1, s2, s3, s4	Sensor pockets	¾"	¾"	¾"	¾"	¾"
e	Clean-out flange (mm)	Ø180/120	Ø180/120	Ø180/120	Ø180/120	Ø180/120

Dimensions

Label	Description	300	400	500	750	1000
H	Height	1630	1915	1925	2020	2030
-	Tilted height	1650	1950	1940	2050	2065
-	Total height including insulation	1740	1975	1985	2080	2090
Do	Outer diameter including insulation	Ø700	Ø750	Ø800	Ø950	Ø1050
Di	Inner diameter	Ø500	Ø550	Ø600	Ø750	Ø850
c	Cold water inlet	65	65	65	65	80
h	Hot water outlet	1395	1670	1670	1725	1735
f1	Flow from heat source (lower)	610	640	615	730	775
r1	Return to heat source (lower)	190	215	215	270	275
f2	Flow from heat source (upper)	1270	1515	1545	1540	1480
r2	Return to heat source (upper)	790	925	865	890	940
y	Secondary return	1120	1330	1285	1430	1480
s1	Sensor pocket	540	325	330	420	420
s2	Sensor pocket	845	980	950	1060	1110
s3	Sensor pocket	1315	1590	1590	1645	1655
s4	Sensor pocket	1415	1690	1690	1745	1755
e	Flange centre point	700	780	740	810	860

Installation Instructions

10. Primary Pipework

The ATSt ranges of hot water tanks are supplied with zero (ATSB), one (ATSI, ATSH), or two (ATST, ATSR) internal heat exchange coils, leading to distinct product ranges depending on the number of coils installed. As a result, the tanks can cater for most hot water applications. The coils fitted within the ATST and ATSR can be used individually for two different heat sources, or can be combined by external, additional pipework (not supplied) to give a larger capacity system. With these combinations the vessel can be used as a preheater, afterheater, or buffer vessel within a water heating system.

Connections to the vessel should be made according to the locations and sizes denoted on pages 7-11. All pipework should be of an appropriate, non-corrosive material, and should be supported outside of the vessel to prevent excessive load bearing upon the tank connection points. Pipework should be arranged to facilitate suitable access to system components. Any flanged connections to the vessel must be tightened in a diametrically opposed sequence to prevent uneven loads across the connection.

While installing pipework, consideration should be given to removal of the coils for maintenance and cleaning of the tank. Valves and union type fittings are required. A drainage connection should be included downstream of the union fittings.

ATST, ATSR Combined Coils

For larger capacity systems with one heat source, the two heating coils can be combined. The standard way to do this is in series so that the primary flows through the top coil and then through the bottom coil. To estimate the total kW capacity with both coils, based on an 80°C primary temperature, add the kW capacity for the top coil at 80°C to the kW capacity for the bottom coil at 70°C. For technical details on kW capacities at 70°C, on different temperatures, or if a more accurate calculation is required, please contact the Advenco Design Department.

ATST, ATSR Separate Coils

In the case of two heat sources, the lower grade heat or less costly energy source should go into the bottom coil to act as a preheat. The more reliable or higher grade heat source (usually a boiler) should be piped into the top coil to ensure that water drawn from the top of the tank is sufficiently heated for use. Note that in such an application, where the lower coil may not reliably achieve sufficient temperatures for Legionella prevention, alternative anti-legionella measures must be included as per the site risk assessment and guidance on page 5.

Installation Instructions

11. Secondary Pipework

General

A standard installation will include the hot water storage tanks or calorifiers as part of a mains-fed system. The pipework should be correctly sized to carry the maximum simultaneous demand of hot water for the building. This may or may not be the same size as the cold feed connection.

Cold Feed

All cold feed pipework must be fitted with safety equipment to prevent overpressure and allow for the expansion of hot water in the system. This must include a check valve and a pressure relief valve set normally to the maximum working pressure of the tank, but no more than 1.5 bar higher than the maximum working pressure in line with the regulations set out in EN 8558 section 4.3.29.1.

All mains-fed systems should additionally include a pressure reducing valve and strainer. The domestic hot water pressure must exceed the primary system pressure at all times to protect against contamination of the DHW in the unlikely event of a leak from the coil.

There must not be any type of isolation between the pressure relief valve and the vessel. Safety equipment should be installed at the cold inlet unless otherwise specified.

The cold feed equipment should be supplied as part of an unvented kit by Adveco Ltd., inclusive of an expansion vessel and temperature and pressure relief valve with a pressure setting at least 0.5 bar above the pressure relief valve setting but no more than 1.5 bar higher than the maximum working pressure of the tank, in line with EN 8558 section 4.3.29.1. A 3/4" inch valve is suitable for use with most indirect systems.

The expansion vessel should be calculated to be roughly 5% of the total hot water system volume for systems operating at around 3 bar. Please contact the Adveco Design Department to obtain a full calculation if required, or for high pressure applications. The expansion vessel pressure must be set equal to the cold fill pressure of the system, and must be set with no pressure on the wet side of the membrane. The expansion vessel must be situated on the cold feed pipe. For tanks arranged in series, only one expansion vessel should be used at the beginning of the system. Consideration may be given to flow-through type expansion vessels for systems identified as high risk.

The expansion vessel branch can have a lock shield valve so long as the relief valve is not on the same branch.

Drain

The cold feed is located at the lowest part of the cylinder to meet anti-Legionella requirements. A drain should be installed in the cold feed at the lowest point, before the connection to the cylinder, or at the bottom of the cylinder for vessels which include a drain connection. The drain valve shall be of suitable size to allow draining of the tank in a reasonable amount of time. It is recommended that a 1/4 turn lever valve and plug or cap are used and that the valve size be one size smaller than the cold feed connection size. A suitable drain or gulley should be provided to allow draining of the tank.

Vented Installations:

In case of a vented system the unvented kit can be omitted. From the hot flow there must be an uninterrupted open vent with no valves, of at least 19mm internal diameter, reaching above the water level of the cold water tank and discharging to a safe place (not into the cold tank). It is considered good practice to fit a temperature and pressure relief valve even on a vented system.

Installation Instructions

12. Discharge Pipework

Discharge from relief valves

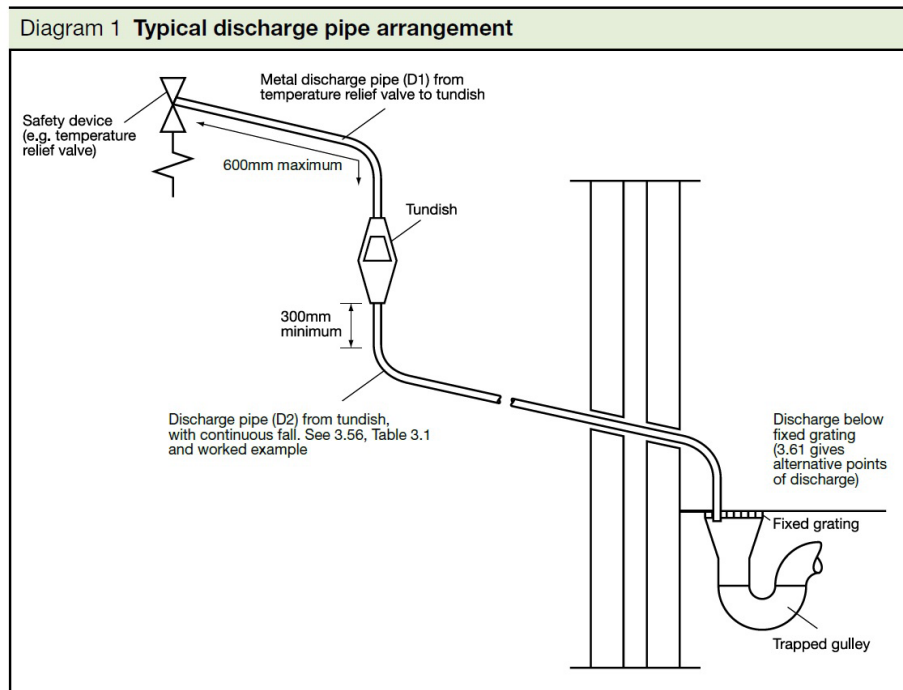

Figure 3: Discharge pipework diagram (as found in Building Regulations Part G).

Discharge pipework requirements for the UK are found in Building Regulation Part G. They are summarised here but it is recommended to read the regulations in full at <http://www.planningportal.gov.uk/buildingregulations/approveddocuments/partg/approved>

D1, the pipe from the relief valve to the air break, must have the same diameter as the valve, must be metal, and must be no longer than 600mm. An airbreak, such as a tundish or a funnel, must be installed at the end of D1.

D2, the pipe from the air break to termination, must be at least one size larger than D1, must have at least 300mm vertical drop before a bend, and must have a continuous fall. It should typically be metal, but PP is acceptable (note: PP is push-fit plastic. ABS and PVC solvent welded plastics are not suitable).

If D2 is longer than 9m total equivalent length (based on 1.4m per bend), then its diameter must be increased. Please refer to Building Regulation G3 at <http://www.planningportal.gov.uk/buildingregulations/>. If a number of D2 pipes are combined, the diameter of the common pipe should be one size larger than the biggest D2 pipe.

D2 should be terminated in one of the following ways:

- Into a soil stack, suitable for the temperature, with a mechanical seal, and with no sanitary appliances on it and a warning not to use the pipe for sanitary appliances.
- Into a trapped gulley with the pipe end below the grate but above the water seal.
- Terminating at low level to a suitable external ground level surface with a guard around the pipe end and that end within 100mm of the ground
- At high level into a suitable hopper or onto a roof that can withstand the temperature and does not have plastic guttering within 3m of the discharge and does not create a risk to people below.

Installation Instructions

13. Secondary Return Pipework

A secondary return is the best way to ensure that there is hot water at the outlets in a short amount of time. In some cases this could be done with trace heating, but the amount of electricity necessary to do this must be considered. In some small systems it is not necessary to use either, and the hot water can flow directly to the taps. The water at the furthest outlet must be 50°C within one minute (55°C in healthcare premises), although this may not be acceptable to all users and a secondary return arrangement should be considered for waiting times of longer than 20 seconds. In all cases, site legionella protection policy takes precedence over this document.

The secondary return pump should be sized to give a suitable flow of hot water around the system to ensure the returning temperature is at least 50°C. The pipework must be insulated. The pump must have a check valve on the positive side of the return pump to prevent cold flow to the hot outlets.

For ATSB, ATSI, and ATSH tank applications, the secondary should return into the cold feed of the water heater.

For the ATST and ATSR twin coil ranges, the secondary should enter the hot water system above any low grade heat sources, just before the final high grade heat source. For a standard indirect water heater installation where both coils are connected together from one heat source, the return should go into the cold feed downstream of the unvented kit / inlet combination safety group. In cases where two heat sources are used, the secondary return should be piped into the centre of the tank.

14. Shunt / Destratification Pump

In installations where the secondary return is piped into the cold feed, it may be considered that all requirements for destratification or purging are met. This must be confirmed by site Legionella risk assessment.

In installations without secondary returns, or when it is piped into the centre of the tank, it is advised that the tank is entirely heated to 60°C for at least one hour per day. This should be done with a destratification pump piped from the outlet to the inlet. It should be timed with a clock to run at a low demand period of the day, while the heat source is on, for long enough that the bottom of the tank will achieve 60°C for one hour. In installations with multiple heat sources, a destratification pump should not run permanently.

For buffer vessel applications, the shunt pump between the buffer outlet and the water heater inlet should be timed to be the same as the water heater.

Installation Instructions

15. Multiple Tanks

In case of a multiple tank system the following must be adhered to:

Series Tanks

Series tanks are used in installations as preheaters and afterheaters. A low grade or renewable heat source is used to heat the preheat and the water is transferred to the afterheater, where the additional energy required will top up the temperature. The afterheater is designed to be able to supply the entire load if necessary, and it is always kept up to temperature while the building is occupied.

1. The unvented kit (with an expansion vessel sized for the entire system) or inlet combination group should be installed on the cold feed side of the preheat vessel.
2. The secondary return should be piped into the inlet of the afterheater.
3. A purge pump should be installed from the afterheater outlet to the preheater inlet to allow for thermal disinfection of the preheat. This can be on a timer or on a controls system to heat the preheat to 60°C as often as required by the risk assessment as referenced on page 5.
4. The afterheater must have a temperature and pressure relief valve.
If it is desirable to be able to drain one tank without affecting the others, an isolation valve can be installed between the two tanks only if another pressure relief valve is installed on the afterheater side of the valve.
No check valve or expansion vessel should be installed between the preheater and afterheater.

Parallel Tanks

1. All pipework including the secondary return to parallel tanks should be balanced either by pyramid or by reverse return.
2. It is best if each tank has its own unvented kit / inlet combination group to allow for easy servicing of each unit. Consideration should be given to one common pressure reducing valve to ensure equal pressure and flow through each tank.
3. The secondary return should connect into each cold feed.

ATSB as a Buffer Vessel

1. Where a buffer vessel is present, all hot water flow into the building must come from the buffer.
2. The cold feed should connect into the water heater.
3. The output from the water heater should connect into the bottom of the buffer vessel.
4. It is advised to include a shunt pump, from the buffer outlet to the inlet of the water heater.
5. An unvented kit / inlet combination group should be installed on the water heater, with a temperature and pressure relief or inlet combination security group valve on the buffer vessel.
6. The secondary return from the building should pass into the cold feed of the water heater.

Installation Instructions

16. Controls

Every hot water vessel must be fitted with a method of temperature control. This can either be a control thermostat in the tank, a sensor, or a differential control between the tank temperature and the heat source. This must be set to ensure a water temperature of at least 60°C throughout the vessel. The temperature control setting should be subject to a risk assessment in accordance with local building regulations. In most cases, it is recommended to fit thermostatic mixing valves on all outlets for personal use.

The temperature control method should be set to provide a water temperature at outlets of at least 50°C (55°C in healthcare premises) within one minute, and a minimum return temperature of 50°C.

Every vessel that contains a heat source must additionally be fitted with a non-self-resetting overheat thermostat capable of preventing heat entering the tank from all sources, by either stopping the primary flow or by turning off the heat source. Stopping the primary flow may be achieved by a spring-loaded zone valve, or by turning off the pump, providing that thermosiphoning cannot occur.

Time control

It is acceptable to shut off the hot water system if the building is unoccupied for a short period over night or on the weekends. Following a short shutdown, the hot water system must come on long enough before occupation so that it has been up to temperature for at least one hour.

Longer shutdowns must be risk assessed and may require complete flushing and disinfection of the system before startup.

Frost protection

In normal working operation, the tank is protected against frost because it will be maintained at temperature. In situations where it will be shut down because the building is unoccupied, consideration must be given to freezing of the water within the tank and pipework. This is best dealt with by a frost thermostat (not supplied as standard) in the room to bring on the heat source and secondary pump at 5°C.

Maintenance Operations

Hot water system maintenance should be determined by the building's risk assessment and legionella protection policy. While full maintenance and cleaning of tanks should be carried out by a trained operative, there are regular hot water system maintenance checks that must be carried out more frequently and can be done by the building controller's nominated person. These include monthly checks of the hot water temperature and regular flushing of low use outlets.

The more involved maintenance regime of a tank will vary from site to site depending on water conditions and use. Maintenance must take place at least yearly, but more frequent visits may be required depending on the condition of the unit after one year. The main reason for frequent maintenance is due to scale formation in the tank. Consideration should be given to scale control in hard water areas to reduce descale frequency.

The maintenance of a tank involves checking the system and cleaning the tank.

Checks to carry out:

Temperature is correct and above 60°C.

Return temperature is above 50°C and in line with relevant local regulations.

Furthest outlet temperature is above 50°C (55°C for healthcare) in 60 seconds.

All control thermostats are calibrated and correctly shuts off heat source.

All overheat thermostats are functional and stop heat input to the tank.

Relief valves operate and discharge correctly.

All valves travel free.

The system has no leaks.

The pressure of any expansion vessel on the cold feed pipework is equal to the cold feed pressure (checked when there is no pressure on the water side of the diaphragm).

Cleaning:

All filters should be cleaned.

The tank should be drained down, cleaned and descaled.

All heater batteries should be descaled.

Drainage Procedure:

Turn off all direct or indirect heat sources connected to the vessel.

Turn off any system pumps and isolate all connections to and from the vessel.

Ensure that the vessel drain connection is connected to, or positioned over, a drain or gully. For pressurised systems, open the drain valve connection to release the pressure within the vessel.

Open a safety valve on the tank to allow air into the unit and prevent negative pressure build-up during drainage.

Alternatively, ensure there is no isolation between the DHW outlet of the tank and a draw-off point, and open the tap.

Allow the water in the pipework to drain, and leave the tap open to allow ingress of air to the vessel.

Allow the vessel to fully drain via the drain valve connection.

Note that for ATSI, ATST, ATSH and ATSR vessels, the indirect heating coils may also need to be drained. This should be done via a drainage point included on the primary pipework.

Technical Specifications

Model ATSB

Description	100	150	200	300	350	400	500	500-II	580	750	860	1000	1000-II
Water volume (l)	102	142	212	289	339	411	490	490	575	756	864	990	983
Standing losses (W)	-	-	53	65	70	75	83	83	106	120	129	140	139
Energy efficiency class	-	-	B	B	B	B	B	B	C	C	C	C	C
Maximum working pressure (bar)	10	10	10	10	10	10	10	10	10	10	10	10	10
Maximum working temperature (°C)	95	95	95	95	95	95	95	95	95	95	95	95	95
Dry mass (kg)	32	37	45	51	57	60	68	68	76	115	125	153	150
Insulation type	Neodul insulation with polystyrene cladding												
Insulation thickness	On demand		100	100	100	100	100	100	100	100	100	100	100

Model ATSI

Description	150	200	300	350	400	500	580	750	1000
Water volume (l)	147	212	289	339	411	490	575	756	990
Standing losses (W)	47	52	63	68	72	79	102	116	135
Energy efficiency class	B	B	B	B	B	B	C	C	C
Maximum working pressure (bar)	Tank	10	10	10	10	10	10	10	10
	Coils	25	25	25	25	25	25	25	25
Maximum working temperature (°C)	Tank	95	95	95	95	95	95	95	95
	Coils	200	200	200	200	200	200	200	200
Dry mass (kg)	40	54	64	75	76	90	95	142	173
Insulation type	Neodul insulation with polystyrene cladding								
Insulation thickness	100	100	100	100	100	100	100	100	100
Nominal flow rate (m³/h)	0.68	1.03	1.60	1.60	1.95	1.95	2.06	2.75	2.75
Lower coil surface area (m²)	0.6	0.9	1.4	1.4	1.7	1.7	1.8	2.4	2.4
Output capacity (80/60:10/60) (kW)	12.7	19.1	29.7	29.7	36.1	36.1	38.3	51.0	51.0
DHW flow rate (80/60:10/60) (l/h)	217.9	327.8	509.7	509.7	619.5	619.5	657.2	875.2	875.2
DHW peak half hour flow (l)	208	306	444	484	587	650	734	969	1157
DHW peak hour flow (l)	319	472	702	742	901	964	1067	1413	1600
DHW peak two hour flow (l)	535	798	1208	1248	1516	1589	1720	2282	2469

Model ATST

Description	200	300	350	400	500	580	750	1000
Water volume (l)	212	289	339	411	490	575	756	990
Standing losses (W)	53	66	71	76	83	105	120	140
Energy efficiency class	B	B	B	B	B	C	C	C
Maximum working pressure (bar)	Tank	10	10	10	10	10	10	10
	Coils	25	25	25	25	25	25	25
Maximum working temperature (°C)	Tank	95	95	95	95	95	95	95
	Coils	200	200	200	200	200	200	200
Dry mass (kg)	60	72	85	90	110	105	160	200
Insulation type	Neodul insulation with polystyrene cladding							
Insulation thickness	100	100	100	100	100	100	100	100
Lower coil nominal flow rate (m³/h)	3	3	4	4	4	4	5	5
Upper coil nominal flow rate (m³/h)	1.5	3	3	3.5	4	4	4	4
Surface area (m²)	Upper coil	0.45	0.8	0.9	0.9	0.9	1.4	1.8
	Lower coil	0.9	1.4	1.4	1.7	1.7	2.4	2.4
Output capacity (80/60:10/60) (kW)	Upper coil	9.5	17.0	19.1	19.1	19.1	29.7	38.3
	Lower coil	19.1	29.7	29.7	36.1	36.1	51.0	59.0
DHW flow rate (80/60:10/60) (l/h)	490.8	801.4	837.4	947.2	947.2	985.0	1384.8	1669.7
DHW peak half hour flow (l)	374	565	620	723	787	870	1182	1488
DHW peak hour flow (l)	623	971	1044	1203	1266	1369	1883	2333

Technical Specifications

Model ATSH

Description		160	200	300	400	500	750	1000
Water volume (l)		172	212	289	411	490	756	990
Standing losses (W)		50	58	66	85	98	120	140
Energy efficiency class		B	B	B	C	C	C	C
Maximum working pressure (bar)	Tank	10	10	10	10	10	10	10
	Coils	20	20	20	20	20	20	20
Maximum working temperature (°C)	Tank	95	95	95	95	95	95	95
	Coils	200	200	200	200	200	200	200
Dry mass (kg)		66	79	96	128	139	185	208
Insulation type		Neodul insulation with polystyrene cladding						
Insulation thickness		100	100	100	100	100	100	100
Lower coil surface area (m ²)		1.4	1.8	2.6	3.8	4.0	5.0	7.0
Output capacity (80/60:10/60) (kW)		29.7	38.3	55.3	80.8	85.1	106.4	148.9
DHW flow rate (80/60:10/60) (l/h)		509.7	657.2	948.9	1386.5	1460.3	1825.8	2555.1
DHW peak half hour flow (l)		350	443	627	907	1000	1366	1857
DHW peak hour flow (l)		608	776	1107	1609	1740	2290	3151
DHW peak two hour flow (l)		1114	1429	2050	2986	3191	4104	5689

Model ATSR

Description		300	400	500	750	1000
Water volume (l)		289	401	490	756	990
Standing losses (W)		66	85	98	120	140
Energy efficiency class		B	C	C	C	C
Maximum working pressure (bar)	Tank	10	10	10	10	10
	Coils	10	10	10	10	10
Maximum working temperature (°C)	Tank	95	95	95	95	95
	Upper coil	95	95	95	95	95
	Lower coil	110	110	110	110	110
Dry mass (kg)		75	86	137	175	268
Insulation type		Neodul insulation with polystyrene cladding				
Insulation thickness		100	100	100	100	100
Surface area (m ²)	Upper coil	2.5	3.0	4.5	5.5	6.5
	Lower coil	1.4	1.5	1.6	2.5	2.8
Output capacity upper coil (80/45:10) (kW)		37	39	42	66	74
Output capacity lower coil (55/45:10) (kW)		29	35	53	65	77

Contact Details & Warranty Information

The Adveco ATsx range, this manual, and all information contained within, are supplied by Adveco Ltd.

UK

Adveco Ltd.
Unit 7&8 Armstrong Mall,
Southwood Business Park,
Farnborough,
Hampshire,
GU14 0NR

T: 01252 551 540
enquiries@adveco.co
www.adveco.co

The Adveco ATSB, ATSI, ATST, ATSH and ATSR ranges are provided with a 2 year vessel warranty reliant upon the following conditions:

- The vessel is correctly and safely stored, installed, and used as instructed by this manual.
- The vessel is filled exclusively with potable water.
- The domestic hot water system is kept in a good condition and is suitably maintained, inclusive of maintenance of the vessel as directed on page 16 of this manual.
- The vessel has not been altered, tampered with, and has not been subjected to damage from frost, vacuum, or external influence.

Exclusions to warranty conditions include:

- Consequential damage arising from malfunction, failure, or leaks associated with the vessel.
- Failure or damage of the vessel or domestic hot water system arising from the build up of excessive scale.
- Any parts and labour charges associated with maintenance, repair, or replacement of the vessel, including gaskets and other consumable/wearing parts.

For further information and warranty claims, please contact Adveco Ltd. through the address listed above.

Adveco Sales Department
T: 01252 551 540 Option 1
E: Sales@adveco.co

Adveco Spares Department
T: 01252 551 540 Option 3
E: Spares@adveco.co

Adveco Technical Department
T: 01252 551 540 Option 4
E: Technical@adveco.co

Adveco Design Department
T: 01252 551 540 Option 5
E: Technical@adveco.co

Adveco Service & Commissioning Department
T: 01252 551 540 Option 6
E: Service@adveco.co

Adveco also offer the following products and services:

- Bespoke system design
- Maintenance and service packages
- Buffer tanks
- Indirect and direct hot water systems
- Off-site manufacturing of skids and plant rooms
- Controls Systems
- Packaged plate heat exchangers
- Solar thermal systems
- Gas fired heating systems
- Air Source Heat Pumps

Appendix A: Product Fiche

(a) Supplier's Name or Trademark	ADVECO LTD.												
(b) Supplier's Model Identifier	ATSB 100	ATSB 150	ATSB 200	ATSB 300	ATSB 350	ATSB 400	ATSB 500	ATSB 500-II	ATSB 580	ATSB 750	ATSB 860	ATSB 1000	ATSB 1000-II
(c) Storage Volume (l)	102	142	212	289	339	411	490	490	575	756	864	990	983
(d) Standing Losses (W)	--	--	53	65	70	75	83	83	106	120	129	140	139
(e) Energy Efficiency Class	--	--	B	B	B	B	B	B	C	C	C	C	C

(a) Supplier's Name or Trademark	ADVECO LTD.									
(b) Supplier's Model Identifier	ATSI 150	ATSI 200	ATSI 300	ATSI 350	ATSI 400	ATSI 500	ATSI 580	ATSI 750	ATSI 1000	
(c) Storage Volume (l)	147	212	289	339	411	490	575	756	990	
(d) Standing Losses (W)	47	52	63	68	72	79	102	116	135	
(e) Energy Efficiency Class	B	B	B	B	B	B	C	C	C	

(a) Supplier's Name or Trademark	ADVECO LTD.							
(b) Supplier's Model Identifier	ATST 300	ATST 350	ATST 400	ATST 500	ATST 580	ATST 750	ATST 1000	
(c) Storage Volume (l)	289	339	411	490	575	756	990	
(d) Standing Losses (W)	66	71	76	83	105	120	140	
(e) Energy Efficiency Class	B	B	B	B	C	C	C	

(a) Supplier's Name or Trademark	ADVECO LTD.							
(b) Supplier's Model Identifier	ATSH 160	ATSH 200	ATSH 300	ATSH 400	ATSH 500	ATSH 750	ATSH 1000	
(c) Storage Volume (l)	172	212	289	411	490	756	990	
(d) Standing Losses (W)	50	58	66	85	98	120	140	
(e) Energy Efficiency Class	B	B	B	C	C	C	C	

(a) Supplier's Name or Trademark	ADVECO LTD.					
(b) Supplier's Model Identifier	ATSR 300	ATSR 400	ATSR 500	ATSR 750	ATSR 1000	
(c) Storage Volume (l)	289	401	490	756	990	
(d) Standing Losses (W)	66	85	98	120	140	
(e) Energy Efficiency Class	B	C	C	C	C	