

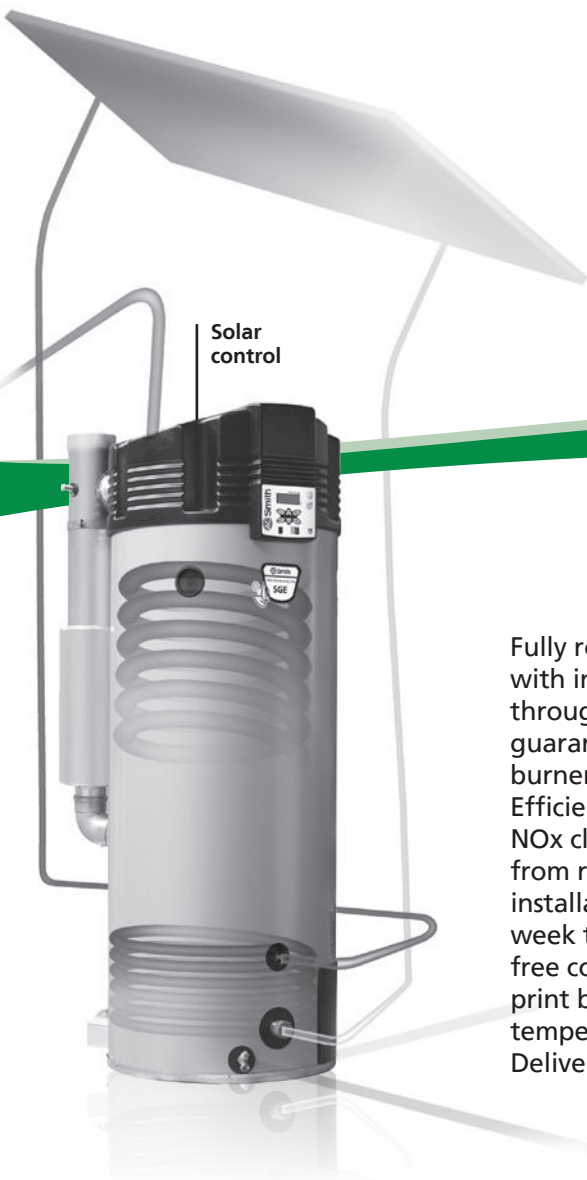

SGE

Condensing Gas - Solar Water Heater

SGE - 40/60



Fully room-sealed condensing high efficiency gas-solar water heater with integrated solar heat exchanger • Maximum solar contribution through fully integrated intelligent solar controller, heat comfort guaranteed • Automatic gas/air premix burning system including burner modulation • Delivered with low-maintenance inert anodes Efficiency **96%** (gross) • NOx emission ≤ 30 ppm (dry – air free) – NOx class 5 • Whisper quiet operation (<45 dB(A) at 2m distance from roof duct) • One control and display unit for the complete installation • Easy fault diagnosis and computer controlled digital week timer • Programmable for legionella purge cycle • Voltage-free contact for general fault indication to BMS • Very small footprint because of integrated solar heat exchanger • Varying water temperature setting from 40°C to 80°C with use of week timer • Delivered on steel base for convenient transport and installation

Features and options

Fully room-sealed condensing high efficiency gas-solar water heater with integrated solar heat exchanger
Maximum solar contribution through fully integrated intelligent solar controller, heat comfort guaranteed
Automatic gas/air premix burning system including burner modulation
Delivered with low-maintenance inert anodes
Efficiency 96% (gross)
NOx emission ≤ 30 ppm (dry – air free) – NOx class 5
Whisper quiet operation (<45 dB(A) at 2m distance from roof duct)
One control and display unit for the complete installation
Easy fault diagnosis and computer controlled digital week timer
Programmable for legionella purge cycle
Voltage-free contact for general fault indication to BMS
Very small footprint because of integrated solar heat exchanger
Varying water temperature setting from 40°C to 80°C with use of week timer
Delivered on steel base for convenient transport and installation
Solar collectors available with ingenious drain-back system to prevent stagnation temperatures from arising in the installation
SGE is compatible with solar collectors or as a stand-alone water heater
Dummy sensor kit: an optional dummy sensor kit available for the SGE to operate without a solar circuit; for use in a staged development

Energy labeling

		SGE 40	SGE 60
Load Profil	-	XXL	XXL
Energy labeling	-	A	A
Efficiency	%	90	92
Annual Electricity Consumption (AEC)	kWh	48	48
Daily Electricity Consumption	kWh	0.259	0.260
Annual Fuel Consumption (AEC)	GJ GCV	21	21
Daily Fuel Consumption	kWh GCV	26.802	26.192
Nitrogen Dioxide Emission (NO2)	mg/kWh GCV	29	31
Mixed Water of 40°C (according V40)	ltr.	∞	∞
Sound Power Level	dB	51	59

Technical specifications

		SGE 40	SGE 60
Gas data natural gas 2H (G20)			
Input*	kW	44.4	63.3
Output	kW	42.8	60.4
Inlet pressure	mbar	20	20
Gas consumption **	m ³ /h	4.2	6.0
Flue gas discharge	°C	50	60
Gas data propane 3P (G31)			
Input*	kW	43.5	62.0
Output	kW	42.8	60.4
Inlet pressure	mbar	37/50	37/50
Gas consumption **	kg/h	3.1	4.4
Flue gas discharge	°C	50	60
General			
Nox	ppm	≤ 30	≤ 30
Noise level	dB	< 45	< 45
Efficiency (gross)	%	96	95
Weight empty	kg	245	245
Maximum weight	kg	615	615
Storage capacity	l	370	370
Max. temperature setting	°C	80	80
Maximum working pressure	kPa (bar)	800 (8)	
Draw-off capacity ***			
Tset = 65°C/ Tcold = 10°C			
30 min. ΔT=44°C	l	470	630
60 min. ΔT=44°C	l	890	1300
90 min. ΔT=44°C	l	1400	1900
120 min. ΔT=44°C	l	1800	2400
Continuous ΔT=44°C	l/h	840	1200
Heating-up time ΔT=44°C	min.	15	10
30 min. ΔT=50°C	l	400	530
60 min. ΔT=50°C	l	760	1100
90 min. ΔT=50°C	l	1200	1600
120 min. ΔT=50°C	l	1500	2100
Continuous ΔT=50°C	l/h	740	1100
Heating-up time ΔT=50°C	min.	17	12
30 min. ΔT=55°C	l	340	480
60 min. ΔT=55°C	l	680	950
90 min. ΔT=55°C	l	1100	1500
120 min. ΔT=55°C	l	1400	1900
Continuous ΔT=55°C	l/h	670	950
Heating-up time ΔT=55°C	min.	18	13
Electrical data			
Power consumption	W	60	120
Power supply	VAC/Hz	230 (-15% +10% VAC)/50 (±1Hz)	
Shipping data			
Weight incl. packaging	kg	256	256
Width packaging	mm	870	870
Height packaging	mm	2100	2100
Depth packaging	mm	945	945

* Gas data on gross value

** Gas consumption at 15°C and 1013,25 mbar

*** Based on nat gas

Dimensions

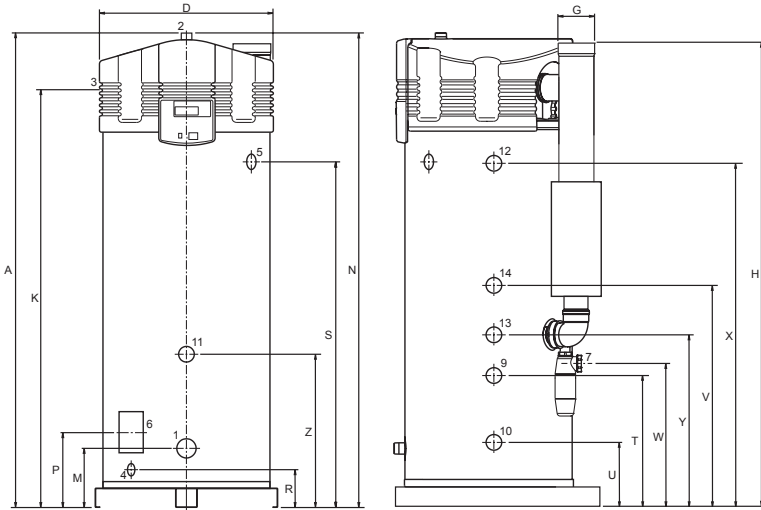
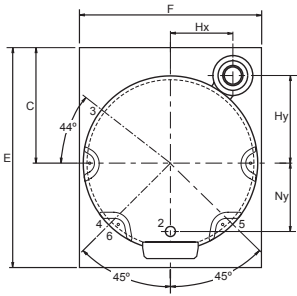

	SGE 40	SGE 60
A	2055	2055
C	490	490
D	705	705
E	925	925
F	850	850
G	100/150	100/150
H	2020	2020
Hx	260	260
Hy	370	370
K	1960	1960
M	185	185
N	2055	2055
Ny	205	205
P	365	365
R	180	180
S	1555	1555
T	630	630
U	305	305
V	1035	1035
W	765	765
X	1465	1465
Y	855	855
Z	755	755
1 Cold water inlet		R 1 1/2
2 Hot water outlet		R 1 1/2
3 Gas valve connection		R 3/4
4 Drain valve connection		3/4"
5 T&P connection		1" - 11.5 NPT
6 Clean out		95x70
7 Condense water connection		Ø 40
9 Connection coil inlet		Rp 1
10 Connection coil outlet		Rp 1
11 Connection electric element		Rp 1 1/2
12 Connection inlet plate heat exchanger		Rp 1
13 Connection outlet plate heat exchanger		Rp 1
14 Connection recirculation		Rp 1
Dimensions in mm.		



Installation diagrams

UNVENTED

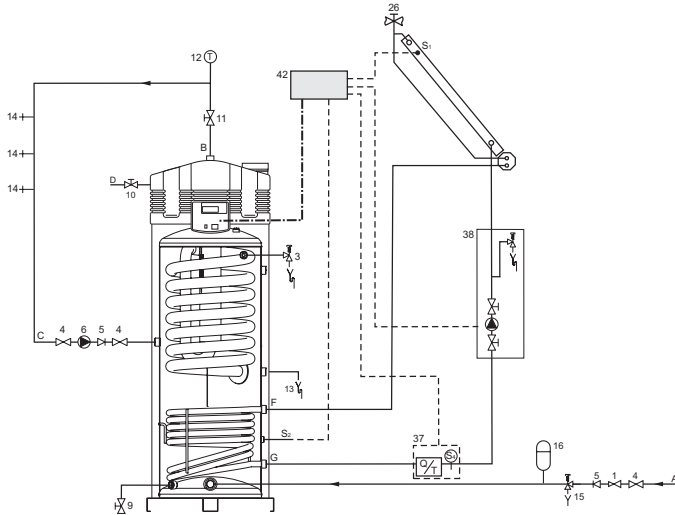

VENTED

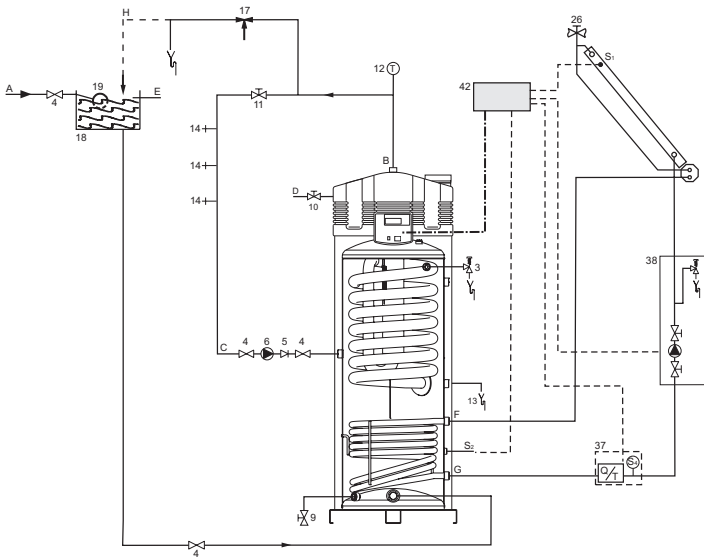

- 3 T&P valve
 - 4 Stop valve
 - 5 Non-return valve
 - 6 Circulation pump
 - 9 Drain valve
 - 10 Gas valve
 - 11 Service valve
 - 12 Temperature meter
 - 13 Condensate drain
 - 14 Hot water outlet
 - 15 Expansion valve
 - 16 Expansion vessel
 - 17 Threeway valve
 - 18 Water cistern
 - 19 Float valve
 - 23 Pressure valve
 - 26 Air bleed
 - 37 Flow sensor
 - 38 Solar pump station
 - 42 Junction box
 - 51 T-collector
 - 52 T-tank
 - 54 T-return solar
- A Cold water supply
 - B Hot water outlet
 - C Circulation pipe
 - D Gas supply
 - E Water overflow
 - F Coil inlet
 - G Coil outlet
 - H Expansion pipe

A.O. Smith unvented system kits utilise combination valves.

In the instruction manual you will find all the necessary information regarding connection, installation and maintenance of the product; including information on the electrical connections.

Information regarding the recycling or disposal of the product can also be found in the manual. This manual is delivered with the appliance and can also be found on our website; www.aosmith.co.uk.

Optional: Theta Dual Service

Theta dual service means using the available hot water from one of our water heaters for both domestic hot water (DHW) and heating. Dual service can be used in combination with a BFC Cyclone, SGE or SGS system. This is a perfect system for locations where a lot of domestic hot water and a little bit of heating is requested.

The intelligent control uses the available hot water very efficiently to meet the heating demand from one system without compromising comfort levels.

THETA MODULE FOR SGE		
Art. No.	kW CH capacity	ΔT CH system
T 20 06	20	06
T 20 10	20	10
T 20 20	20	20
T 30 06	30	06
T 30 10	30	10
T 30 20	30	20
T 40 06	40	06
T 40 10	40	10
T 40 20	40	20

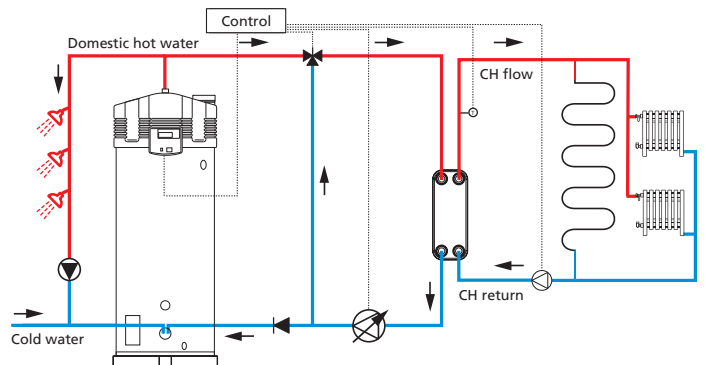

- Plate heat exchanger – single separation (a double separated plate heat exchanger can be delivered upon request)
- Primary DHW pump
- Temperature sensor with cable incl. clip
- Three-way mixing valve including cables
- Instruction manual

Further information is available on our website: www.aosmith.co.uk

Installation options

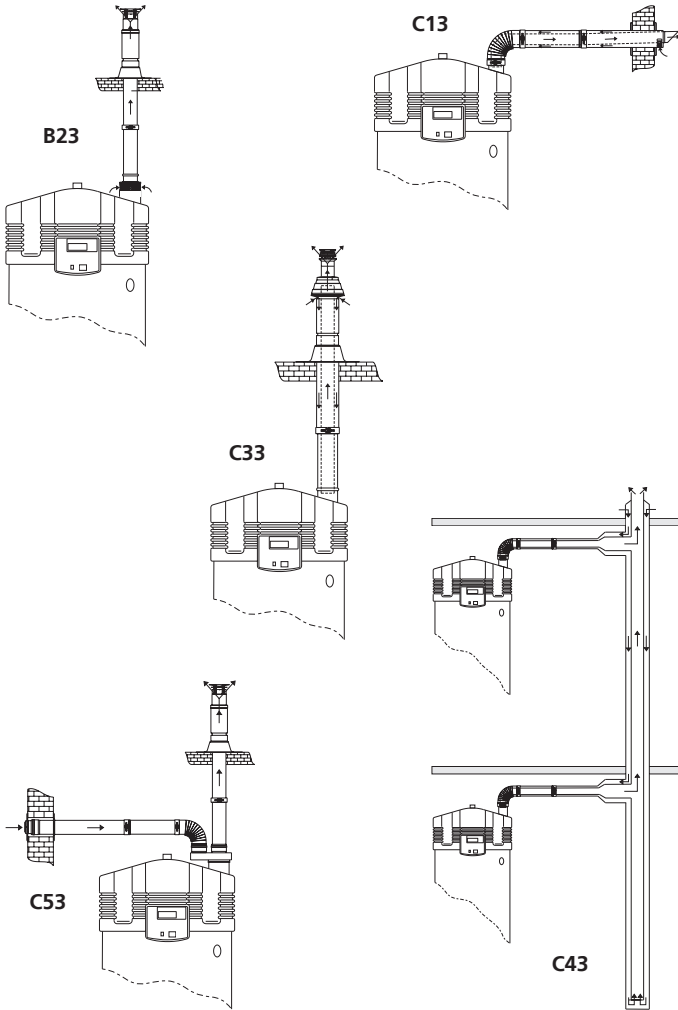

Further information on the specific flue discharge materials can be found in the installation manual.

A SGE water heater should be installed according category B23, C13, C33, C43 or C53*.

	SGE 40	SGE 60
Concentric		
Diameter (mm)	100/150	100/150
Max. length (m)	40	40
Max. 45/90° bends	7	7
Parallel (standard diameter)		
Diameter (mm)	100	100
Max. length (m)	55	55
Equivalent/bend 90° (m)	4,6	4,6
Equivalent/bend 45° (m)	1,2	1,2
Parallel (larger diameter for more length)		
Diameter (mm)	130	130
Max. length (m)	100	100
Equivalent/bend 90° (m)	2,4	2,4
Equivalent/bend 45° (m)	1,4	1,4
* All SGE water heaters are also approved for installations where the unit is supplied without venting materials (C63).		
Concentric flues		
It is not permitted to use more than the specified number of bends, even when the duct is shorter than the maximum length. A 45° bend is equivalent to a 90° bend.		
Parallel flues		
- The maximum permissible length should be reduced by the equivalent length of each bend. (Note: for a parallel installation this means that 3 changes in direction amount to 6 bends (3 in the supply duct and 3 in the flue).		
- The maximum length also applies if a parallel installation has different supply and flue duct lengths (B23, C53).		
- Combined flues (C43) shall be fitted with a condensate drain.		
Note: horizontal flue runs must be installed with a fall of at least 5 cm per metre.		

Minimum space requirements

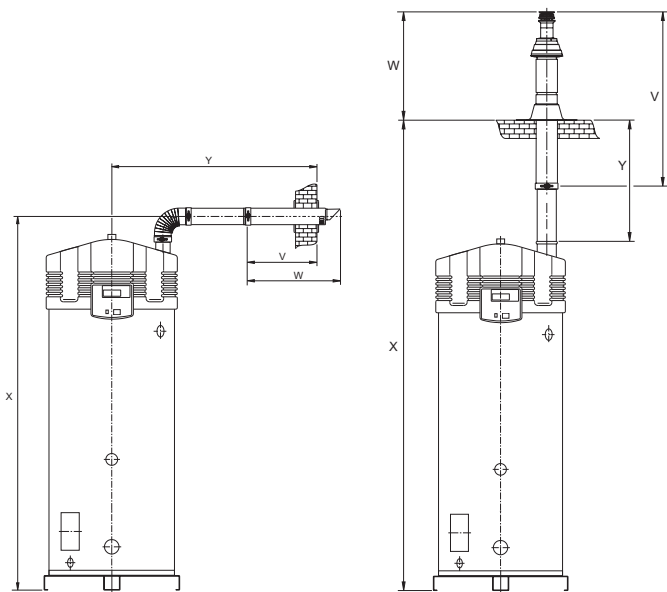

	SGE 40 Ø100/150	SGE 60 Ø100/150
Minimal space for wall duct (mm)		
V	550	550
W	790	790
X	2335	2335
X *	2785	2785
Y	1475	1475
Y *	1025	1025
Minimal space for roof duct (mm)		
V	1500	1500
W	1035	1035
X	3585	3585
X **	2635	2635
Y	1415	1415
Y **	465	465

* Distance without concentric pipe between bend and wall duct.
** Distance without concentric pipe between appliance and roof duct.

Data subject to change UK/1216/SGE/10
Terms and conditions apply, please refer to our website.