

# ADVECO



CE

UK  
CA



Guidebook for installation, handling and maintenance – ENG

## Advenco S70÷S100 Electric Boilers

Electric hot water boiler for heating systems with thermoregulatory microprocessor

## Content

### 1. Explanation of symbols and instructions for safe work

- 1.1 Explanation of symbols
- 1.2 Instructions for safe work

### 2. Device information

- 2.1 Overview of types
  - 2.1.1 Declaration of conformity
  - 2.1.2 Proper use
- 2.2 Instructions for installation
- 2.3 Operating instructions
- 2.4 Freezing protection agents and inhibitors
- 2.5 Norms, regulations and standards
- 2.6 Tools, materials and auxiliary components
- 2.7 Minimum spacing and flammability of construction materials
- 2.8 Product description
- 2.9 Waste disposal
- 2.10 Range of delivery
- 2.11 Factory tile
- 2.12 Transport

### 3. Dimensions and technical data

- 3.1 Dimensions of the device
- 3.2 Components
- 3.3 Technical data for Adveco Standard 70-100kW

### 4. Installation of the device

- 4.1 Warnings before mounting
- 4.2 Distances
- 4.3 De-mounting of front casing
- 4.4 Boiler mounting
- 4.5 Hydraulic connections
- 4.6 Filling the installations and watertight testing
  - 4.6.1 Filling the boiler with water and testing the seal
  - 4.6.2 Heating pump air emission and de-blocking
  - 4.6.3 Boiler and installation air emission

### 5. Electrical connection

- 5.1 Connecting the boiler to the electrical grid
- 5.2 Connecting power (voltage) cable
- 5.3 Scheme for connecting power (voltage) cable
- 5.4 Electrical schemes

### 6. Commissioning

- 6.1 Before commissioning
- 6.2 First start
- 6.3 Setting the Flow Switch indicator
- 6.4 Start-up log

### 7. Operation of the device

- 7.1 Safety instructions
- 7.2 Overview of controls and protection elements
  - 7.2.1 Boiler control panel
  - 7.2.2 Modes of operation
  - 7.2.3 Manual mode
  - 7.2.4 The principle of operation in manual mode
  - 7.2.5 Setting temperature
  - 7.2.6 Setting power
  - 7.2.7 Setting time and date
- 7.3 OTC (Outdoor Temperature Compensation) Boiler Operation Mode (OPTIONAL)
  - 7.3.1 Choice of boiler operating mode
  - 7.3.2 24-hour programming
  - 7.3.3 Adjusting the working curve
  - 7.3.4 Symbols on display in OTC mode

- 7.3.5 Warnings and errors

- 7.3.6 Error and warning priorities

- 7.3.7 Protective elements

### 7.4 Switchboard

- 7.4.1 Arrangement of components on the switchboard

- 7.4.2 Switchboard and the top plate of the boiler

### 7.5 External condition for operation - Start / Stop signal

### 7.6 Heating interruption

- 7.6.1 Putting the boiler out of operation

### 8. Cleaning and maintenance

- 8.1 Boiler cleaning

- 8.2 Check the working pressure

- 8.3 Refilling water and venting the installation

- 8.4 Inspection and maintenance log

### 9. Environment protection / Waste disposal

### 10. Troubles and troubleshooting



### 11. Product data sheet

(in accordance with EU regulation no. 811/2013)

# 1. Explanation of symbols and instructions for safe work

## 1.1 Explanation of symbols

### Warnings

	Warnings in text are marked by gray triangle, background warnings are framed
	Electric shock danger is marked by lightning symbol in warning triangle

The signal words at the beginning of the warning mean the way and level of consequences if protective measures are not applied

- **NOTE** means that smaller material damages may occur
- **CAUTION** means that smaller to middle injuries may occur
- **WARNING** means that heavy injuries may occur
- **DANGER** means that heavy injuries may occur

### Important information

	Important information, meaning no danger for people and things, are marked by the symbol displayed in the following text. These are limited by lines, above and below the text
---	--

### Further symbols

Symbol	Meaning
▶	Action step
→	Directives to other places in document or to other documents
•	Enumeration/Entry from the list
–	Enumeration/Entry from the list (2.)

## 1.2 Instructions for safe work

### General safety instructions

Non-compliance with safety instructions may cause heavy injuries – or lethal outcomes and material damages and environment pollution.

- ▶ Electrical installation should be examined by an expert prior to the device assembly.
- ▶ All electric works should be performed by authorised person in accordance with corresponding regulations.
- ▶ Commissioning and maintenance and repairs should be done by authorised service only.
- ▶ Technical acceptance of installations should be performed in accordance with corresponding regulations.

### Danger because of disrespecting security rules in alert situations, for example fire.

- ▶ Never expose your-self to life danger. Own security always has priority

### Damage occurred because of wrong handling

Wrong handling may lead to injuries of persons and/or installation damage.

- ▶ Make sure that device is available only to professionals.
- ▶ Installation and commissioning, and maintenance and repair, must be done only by service authorised for electrical works.

### Installation and commissioning

- ▶ Placement of device can be done only by authorised service.
- ▶ Boiler can be turned on only if installation is with corresponding pressure level and working pressure regular. Do not close security valves in order to avoid damage caused by too high pressure. During warming water can leak on security valve of the hot water circuit and hot water pipes.
- ▶ Install this device only in the room where freezing is not possible to occur.
- ▶ Do not store or dispose inflammable materials or liquids in the vicinity of this device. Keep safe distance in accordance with valid regulations

### Life threat of electric power shock

- ▶ Secure electric power connecting is done by authorised service! Comply with connecting scheme
- ▶ Prior to any work: turn off electric power supply. Secure against accidental turn on
- ▶ Do not mount this device in moist rooms

### Control examination / Maintenance

- ▶ Recommendation for user: conclude agreement on maintenance with authorised service to perform annual maintenance and controlling examinations
- ▶ User is responsible for safety and environmental acceptance of the installation
- ▶ Comply with safety work instruction as given in the chapter *Cleaning and Maintenance*

### Authentic spare parts

There shall not be undertaken any responsibility for damage occurred due to spare parts not delivered by the manufacturer

- ▶ Use only original spare parts

### Material damages due to freezing

- ▶ When there is damage due to freezing drain water from the boiler, tank and pipelines for heating. Danger of freezing does not exist only when entire installation is dry

### Instructions for service

- ▶ Inform users about mode of work of device and instruct them in maintenance
- ▶ Inform users not to perform any modifications or repair on their own
- ▶ Warn users that children cannot stay near heating installations
- ▶ Fill in and submit Commissioning log and Handover log attached in this document
- ▶ Deliver technical documentation to the user

### Waste disposal

- ▶ Dispose packaging materials in ecologically Acceptable manner
- ▶ Secure device in ecologically acceptable manner and in authorised place

### Cleaning

Clean outside of device with wet cloth

## 2. Device information

These instructions contain important information about safe and professional assembly, commissioning and maintenance of the boiler.

These instructions are for installers who have knowledge for work with heating installations due to their professionalism and experience.

### 2.1 Overview of types

This manual applies to the following types:

<b>Advenco Standard Electric Boilers</b>	<b>70, 80, 90, 100 kW</b>
--	---------------------------

#### 2.1.1 Declaration of conformity

We declare that the devices are tested in accordance with the directives 2014/35/EU (Low Voltage Directive, LVD) and 2014/30/EU (Electromagnetic Compatibility Directive, EMC).

#### 2.1.2 Proper use

The boiler can only be used for heating hot water and indirectly for preparation of hot water. To ensure proper use, one must follow the operating instructions, the data on the factory tile and the technical data.

### 2.2 Instructions for installation



Use only original spare parts of the manufacturer or spare parts approved by the manufacturer. There shall not be any responsibility for damages caused by spare parts which have not been delivered by the manufacturer

When installing the heat system please abide to the following:

- Valid regulations in construction industry
- Regulations and norms on safety-technical equipment of heating installations
- Changes on the place of mounting according to valid regulations

### 2.3 Operating instructions

When working with heating installation follow next instructions:

- ▶ Boiler should work in working range up to max temperature of 90°C and min pressure of 0.4 bars to max pressure of 4 bars, which should be controlled on regular basis
- ▶ Boiler should be operated only by adults with technical knowledge and qualifications to work with heating systems and which are acquainted with the instructions and operation of the boiler
- ▶ Do not close safety valve
- ▶ Inflammatory objects must not be put on the boiler surface or close to it (within safety distance)
- ▶ Boiler surface clean only with non-inflammatory products
- ▶ Inflammatory substances do not keep in the room for boiler installation (e.g. petroleum, oil, etc.)
- ▶ No lids should be opened during the operation
- ▶ Keep a safe distance according to the applicable local regulations

### 2.4 Freezing protection agents and inhibitors

It is not allowed to use protective products against frost neither inhibitors. If it is not possible to avoid anti-frost protection then should use anti-frost products allowed for heating installations.



Anti-frost products:

- ▶ Reduce lifetime of the boiler and its parts
- ▶ Reduce heat transmission

### 2.5 Norms, regulations and standards

The product is in compliance with the following norms and regulations:

- BS EN 50110-1:2013; EN 50110-1:2013 – Operation of electrical installations - Part 1: General requirements
- BS EN 55014-1:2017; EN 55014-2:2015; EN 55014-1:2017; EN 55014-2:2015 – Electromagnetic compatibility - Requirements for household appliances, electric tools and similar apparatus - Part 1: Emission - Part 2: Immunity - Product family standard
- BS EN 60335-1:2012; EN 60335-1:2016 Household and similar electrical appliances - Safety - Part 1: General requirements
- BS EN 61000-3-2:2019; EN 61000-3-2:2019 Electromagnetic compatibility (EMC) - Part 3-2: Limits - Limits for harmonic current emissions
- BS EN 61000-3-3:2013/A1:2019; EN 61000-3-3:2014/A1:2020 Electromagnetic compatibility (EMC) - Part 3-3: Limits - Limitation of voltage changes, voltage fluctuations and flicker in public low-voltage supply systems

### 2.6 Tools, materials and auxiliary components

Boiler installation and maintenance requires standard tools used in the area of installation of heating systems, plumbing and electrical installations.

### 2.7 Minimum spacing and flammability of construction materials

Depending on valid regulations, other minimum distances could be applied, different than mentioned below.

- ▶ Comply with regulations of electrical installations and minimum distances which are in force in the subject country
- ▶ Minimum distance for heavy inflammable and self-extinguishing materials is 200 mm

Inflammability of components		
A	Non-inflammable	
A1:	Non-inflammable	Asbestos, stone, wall tiles, baked clay, plaster (with no organic additives)
A2:	With smaller quantity of added elements (organic components)	Plaster cardboards plates, base felt, glass fibres, plates of ACUMIN, ISOMIN, RAIOT, LOGNOS, VELOX, AND HERACLITUS
B	Inflammable	
B1:	Hardly inflammable	Beech, oak, veneered wood, felt, HOBREX, VERSALIT and UMAKART plates
B2:	Normally inflammable	Pine, larch and spruce, veneered wood
B3:	Inflammable	Asphalt, cardboard, cellulose materials, tar-paper, plywood plates, cork plates, polyurethane, polystyrene, polyethylene, floor fibre materials

**Table 1:** Ignitable materials and composition of elements according to DIN 410



## DECLARATION OF CONFORMITY



manufacturer / company name: **MIKOTERM DOO**  
**Serbia, 18252 Merošina, Industrijska zona Aleksandrovo, Niška bb**  
 for product: **Electric boiler for heating systems**  
 Models: 'S' Standard  
 Types: **Power 50kW, 60kW, 70kW, 80kW, 90kW, 100kW, 120kW, 140kW, 160kW, 180kW, 200kW, 240kW**

on the basis of test reports from authorised laboratory declaration confirms that the objects of declaration described above is in conformity with requirements of the following documents:

**2014/35/EU LOW VOLTAGE DIRECTIVE (LVD)**  
**2014/30/EU ELECTROMAGNETIC COMPATIBILITY (EMC)**

**Manufacturer declares that appliance described above is tested in authorised laboratory.**

**applied LVD standards:**  
 EN 50110-1:2013  
 EN 60335-1:2016

**applied EMC standards:**  
 EN 55014-1:2017; EN 55014-2:2015  
 EN 61000-3-2:2019  
 EN 61000-3-3:2014/A1:2020

**According to test reports from internal testing.**

MIKOTERM DOO, SRBIJA 18252 Merošina, Industrijska zona Aleksandrovo, Niška bb, tel: 00 381 18 45 42 002  
 M.B.17007203, PIB: 101466454  
 e-mail: office@mikoterm.com, prodaja@mikoterm.com, teh.podrska@mikoterm.com,  
 www.mikoterm.com



## DECLARATION OF CONFORMITY



manufacturer / company name: **MIKOTERM DOO**  
**Serbia, 18252 Merošina, Industrijska zona Aleksandrovo, Niška bb**  
 for product: **Electric boiler for heating systems**  
 Models: 'S' Standard  
 Types: **Power 50kW, 60kW, 70kW, 80kW, 90kW, 100kW, 120kW, 140kW, 160kW, 180kW, 200kW, 240kW**

on the basis of test reports from authorised laboratory declaration confirms that the objects of declaration described above is in conformity with requirements of the following documents:

**ELECTRIC EQUIPMENT (SAFETY) REGULATIONS 2016**  
**ELECTROMAGNETIC COMPATIBILITY REGULATIONS 2016**  
**BS 1894 - SPECIFICATION FOR DESIGN AND MANUFACTURE OF ELECTRIC BOILERS OF WELDED CONSTRUCTION**

**Manufacturer declares that appliance described above is tested in authorised laboratory.**

**Electric equipment (safety) regulations 2016:**  
 BS EN 50110-1:2013  
 BS EN 60335-1:2012

**Electromagnetic compatibility regulations 2016:**  
 BS EN 55014-1:2017; EN 55014-2:2015  
 BS EN 61000-3-2:2019  
 BS EN 61000-3-3:2013/A1:2019

**According to test reports from internal testing.**

MIKOTERM DOO, SRBIJA 18252 Merošina, Industrijska zona Aleksandrovo, Niška bb, tel: 00 381 18 45 42 002  
 M.B.17007203, PIB: 101466454  
 e-mail: office@mikoterm.com, prodaja@mikoterm.com, teh.podrska@mikoterm.com,  
 www.mikoterm.com



MIKOTERM DOO, SRBIJA 18252 Merošina, Industrijska zona Aleksandrovo, Niška bb, tel: 00 381 18 45 42 002  
 M.B.17007203, PIB: 101466454  
 e-mail: office@mikoterm.com, prodaja@mikoterm.com, teh.podrska@mikoterm.com,  
 www.mikoterm.com

IZJAVA O USAGLAŠENOSTI  
(Declaration of conformity)

**Proizvođač (manufacturer)** Mikoterm doo, RS, 18252 Merošina, Industrijska zona Aleksandrovo, Niška bb  
 izjavljuje da su električni kotlovi, proizvedeni u Društvu za proizvodnju, inženjering i marketing Mikoterm doo, u potpunosti u skladu sa standardima EU propisanim za ove uređaje.  
 declares that product electric boilers for heating systems are manufactured completely according to regulatory standards of EU directives for safety and quality of this product.

**Model – tržišno ime / market name:**  
 'S' Standard, 50kW, 60kW, 70kW, 80kW, 90kW, 100kW, 120kW, 140kW, 160kW, 180kW, 200kW, 240kW

**2014/35/EU LOW VOLTAGE DIRECTIVE (LVD)**  
**2014/30/EU ELECTROMAGNETIC COMPATIBILITY (EMC)**

**applied LVD standards:**

**EN 50110-1:2013** – Operation of electrical installations – Part 1: General requirements  
**EN 60335-1:2016** – Household and similar electrical appliances – Safety - Part 1: General requirements

**applied EMC standards:**

**EN 55014-1:2017; EN 55014-2:2015** – Electromagnetic compatibility – Requirements for household appliances, electric tools and similar apparatus – Part 1: Emission - Part 2: Immunity – Product family standard  
**EN 61000-3-2:2019** – Electromagnetic compatibility (EMC) - Part 3-2: Limits – Limits for harmonic current emissions  
**EN 61000-3-3:2014/A1:2020** – Electromagnetic compatibility (EMC) – Part 3-3: Limits - Limitation of voltage changes, voltage fluctuations and flicker in public low-voltage supply systems

Za MIKOTERM DOO / for and behalf of MIKOTERM DOO

Vladimir Ivanović - direktor



MIKOTERM DOO, SRBIJA 18252 Merošina, Industrijska zona Aleksandrovo, Niška bb, tel: 00 381 18 45 42 002  
 M.B.17007203, PIB: 101466454  
 e-mail: office@mikoterm.com, prodaja@mikoterm.com, teh.podrska@mikoterm.com,  
 www.mikoterm.com

IZJAVA O USAGLAŠENOSTI  
(Declaration of conformity)

**Proizvođač (manufacturer)** Mikoterm doo, RS, 18252 Merošina, Industrijska zona Aleksandrovo, Niška bb  
 izjavljuje da su električni kotlovi, proizvedeni u Društvu za proizvodnju, inženjering i marketing Mikoterm doo, u potpunosti u skladu sa standardima EU propisanim za ove uređaje.  
 declares that product electric boilers for heating systems are manufactured completely according to regulatory standards of EU directives for safety and quality of this product.

**Model – tržišno ime / market name:**  
 'S' Standard, 50kW, 60kW, 70kW, 80kW, 90kW, 100kW, 120kW, 140kW, 160kW, 180kW, 200kW, 240kW

**ELECTRIC EQUIPMENT (SAFETY) REGULATIONS 2016**  
**ELECTROMAGNETIC COMPATIBILITY REGULATIONS 2016**  
**BS 1894 - SPECIFICATION FOR DESIGN AND MANUFACTURE OF ELECTRIC BOILERS OF WELDED CONSTRUCTION**

**Electric equipment (safety) regulations 2016:**

**BS EN 50110-1:2013** – Operation of electrical installations – Part 1: General requirements  
**BS EN 60335-1:2012** – Household and similar electrical appliances – Safety - Part 1: General requirements

**Electromagnetic compatibility regulations 2016:**

**BS EN 55014-1:2017; EN 55014-2:2015** – Electromagnetic compatibility – Requirements for household appliances, electric tools and similar apparatus – Part 1: Emission - Part 2: Immunity – Product family standard  
**BS EN 61000-3-2:2019** – Electromagnetic compatibility (EMC) - Part 3-2: Limits – Limits for harmonic current emissions  
**BS EN 61000-3-3:2013/A1:2019** – Electromagnetic compatibility (EMC) – Part 3-3: Limits - Limitation of voltage changes, voltage fluctuations and flicker in public low-voltage supply systems

Za MIKOTERM DOO / for and behalf of MIKOTERM DOO

Vladimir Ivanović - direktor



## 2.8 Product description

Advenco Standard components of boiler:

- Boiler bowl with electric heaters
- Boiler control panel with automatic control
- Boiler sheath with doors
- Dashboard

Boiler can be installed as integral part of the central heating system, floor heating, hybrid, or accumulation systems.

The boiler bowl is made of steel sheet, tested at a pressure of 6bar and the maximum working pressure is 4bar. The boiler is mounted on the floor and can be fixed if necessary.

Electric heaters are mounted in the boiler bowl and fastened to the upper plate by a tourniquet. The built-in thermal insulation between the boiler and boiler shell reduces the loss of heat energy. At the same time, insulation also protects against noise.

Hydraulic connections (DN50 PN16) are located at the back of the boiler. The automatic air valve (vent valve) and the safety valve (3/4" 4bar) are mounted on the thrust connection. The fill / drain tap and flow switch are mounted on the return port. The pressure and temperature sensors as well as the limit thermostatic probe are located on the upper boiler plate.

The boiler sheath is made of decapitated sheet metal and protected by the electrostatic plastification process. On both sides there are vent openings for ventilation of the ambient of the dashboard. Cable glands are located on the bottom side of the boiler front zone. There is a lid on the upper side of the casing whose removing grants access to electric heaters mounted on the boiler top plate. Front side of the device has two doors.

The upper door has a window on it to allow easy value tracking of all relevant boiler parameters, both default and current. By opening the upper door, access is made to the control panel with the main boiler switch, microprocessing thermoregulator (CPU) with LCD display, showing all the data important for boiler operation, safety thermostat and signal lamp for indicating eventual problems with the boiler operation.

Lower doors cover the dashboard with boiler automatics and compact switches for power cable connecting as well as auxiliary connecting cables:

- Commands for circulation pump
- Signal for remote switching on / off (on/off signal), (room thermostat, external working condition, BMS signal, etc.)

The lower doors must be closed while the boiler is operating, and only qualified personnel are allowed to access them and automated switches.

## 2.9 Waste disposal

- Dispose packaging materials in ecologically sound manner
- Components that should be changed dispose in ecologically sound manner

## 2.10 Range of delivery

During the boiler delivery check the following::

- ▶ Check if packaging is damaged during delivery
- ▶ Check if delivery is complete

Part	Pieces
Advenco Standard Electric Boiler	1
Instructions manual	1

## 2.11 Factory tile

The factory tile is located on the back side of the boiler and contains the following technical data:

- Boiler type
- Serial number
- Power
- Input power
- Maximal temperature
- Working pressure
- Water volume
- Mass
- Electric power supply
- Protection grade
- Manufacturer

## 2.12 Transport



### NOTE: Damages during transport

- ▶ Pay attention to transport instructions located on the back side of the packaging.
- ▶ Use suitable means of transport, eg. bag carts with clasps. During transport, product should be in standing position.
- ▶ Avoid impacts or collisions

- Packed boiler put on carts, if needed secure it with strip and drive it to its mounting place
- Remove packaging
- Remove packaging materials and dispose it in ecologically acceptable manner

### 3. Dimensions and technical data

#### 3.1 Dimensions of the device

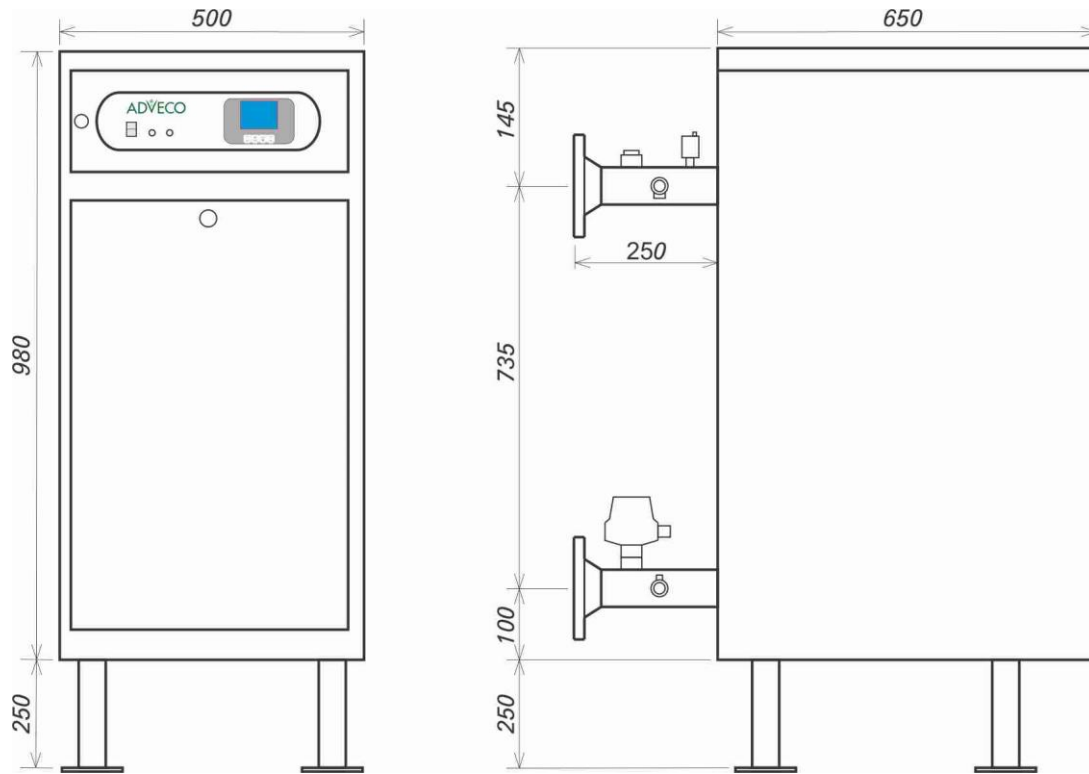

**Image 1:** Dimensions and connections of Adveco Standard 70 ÷ 100kW

#### 3.2 Components

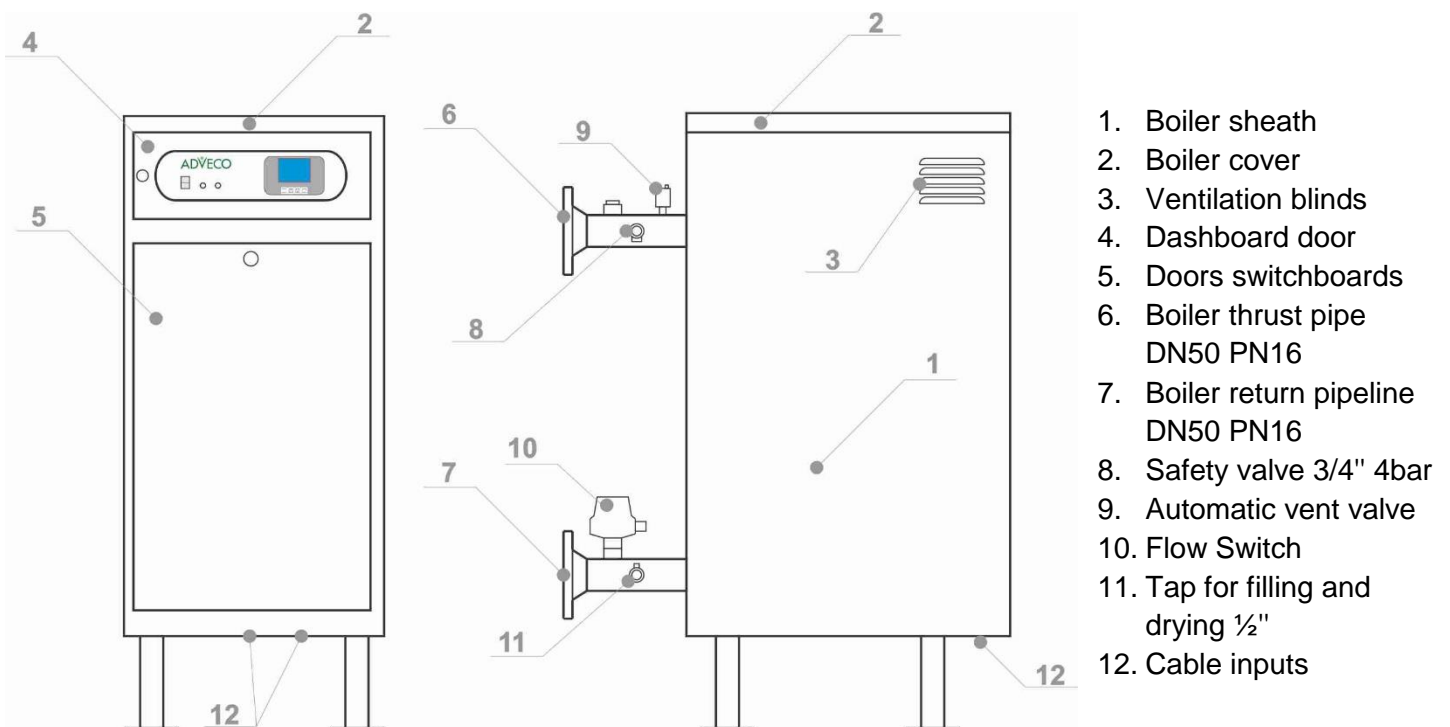

**Image 2:** Components of Adveco Standard 70 ÷ 100kW

## 3.3 Technical data for Adveco Standard 70 ~ 100kW

	Unit	S 70kW	S 80kW	S 90kW	S 100kW
Power	kW	70	80	90	100
Usability level	%	99	99	99	99
Number of power grades		7	8	9	10
Division of power grades	kW	7×10	8×10	9×10	10×10
Network voltage	V AC	3N ~ 400/230V 50Hz			
Protection level		IP20			
Fuse for heater (safety mechanism)	A	7x 3p C25A	8x 3p C25A	9x 3p C25A	5x 3p C40A
Rated current	A	3x101,5	3x116	3x130	3x145
Necessary main fuses	A	3x125	3x125	3x160	3x160
Min diameter of input cable	mm <sup>2</sup>	Cu 3x50	Cu 3x70	Cu 3x70	Cu 3x70
Min diameter of protective cable	mm <sup>2</sup>	Cu 1x25	Cu 1x25	Cu 1x35	Cu 1x35
Safety valve	bar	4			
Max allowed working pressure	bar	3,6			
Min allowed working pressure	bar	0,4			
Boiler operating temperature range	°C	10 ÷ 90			
Safety thermostat	°C	95			
Water volume in boiler	ℓ	95			
Connection of start line		DN50 PN16 (2")			
Connection of return line		DN50 PN16 (2")			
Device mass (without water)	kg	92	106	110	120
Dimensions	mm	500x650(+250)x1240 (Width × Depth × Height)			
Microprocessor Unit		EK_CPU_1_3 fw: 2.p3			

Table 2: Technical data of Device

P [kW]	70	80	90	100
DN	50	50	50	50
Qmin [m <sup>3</sup> /h]	3.5	4	4.5	5
Qmax [m <sup>3</sup> /h]	11	12	15	16
Q= f {ΔT [°C]} [m <sup>3</sup> /h]				
5	9.45	10.8	13.5	15
10	4.7	5.4	6.8	7.5
15	3.6	4.1	5.2	5.7
20	2.5	2.8	3.6	3.9

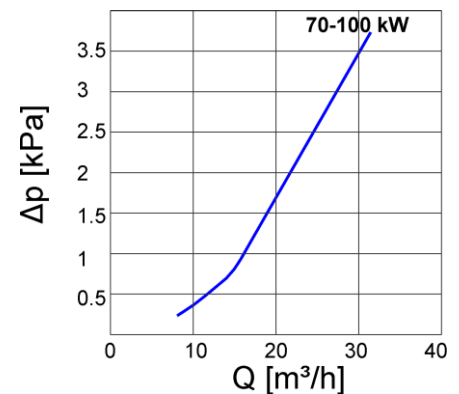

Min and Max Flow, and Flow Rate as a function of ΔT

Pressure drop through the boiler



## 4. Installation of device



**CAUTION:** Human or material damages occurred because of irregular installation!

- ▶ Never install boiler without expansion dish (AG) and safety valve
- ▶ The boiler must not be installed in protected areas where there is moisture, as well as in places with high concentrations of soot and dust



**NOTE:** Material damage due to freezing!

- ▶ Boiler must be installed only in room safe of freezing

### 4.1 Warnings before mounting



**NOTE:** Damage caused by failure to follow further instructions!

- ▶ Follow the instructions for the boiler and all installed components

Prior to installing take care of the following:

- All electrical connectors, protective measures and fuses should be done by professional person respecting all valid norms, regulations and local laws
- Electric connector should be done according to the connecting plans
- After corresponding installation of device execute grounding of the plant
- Before opening device and all works turn off electric supply
- Non-professional and non-authorized attempts to connect device under voltage can produce material damage of device and hazardous electrical shocks

### 4.2 Distances



**DANGER:** Fire threat due to burnable materials and liquids!

- ▶ Do not dispose burnable materials and liquids close to the boiler
- ▶ Let know the user the valid regulations for minimum distances from burnable materials (section 2.7)

- Comply with the regulations for electrical installations and minimum distances in force in certain countries.
- Position the boiler in such a way that there is free space near and above - as shown in Image 3

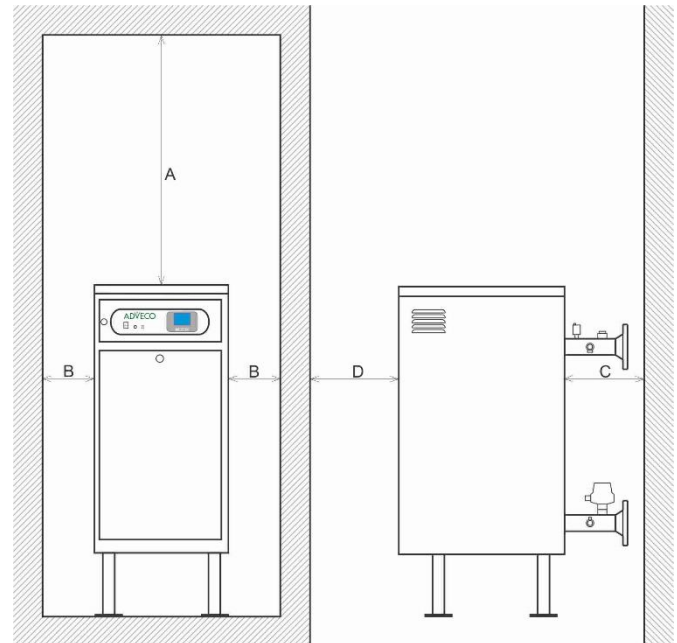

**Image 3 :** Minimum distance during installation

**A = 700mm / B = 500mm / C = 700mm / D = 1000mm**

### 4.3 De-mounting of front casing

The switchboard door must be removed for easy connection to the mains and for installation.

- 1) Unlock the door lock
- 2) Gently pulling forward, open the door covering the switchboard of the boiler
- 3) Pulling upwards remove the door from the boiler
- 4) Slide the door to the side to access the switchboard

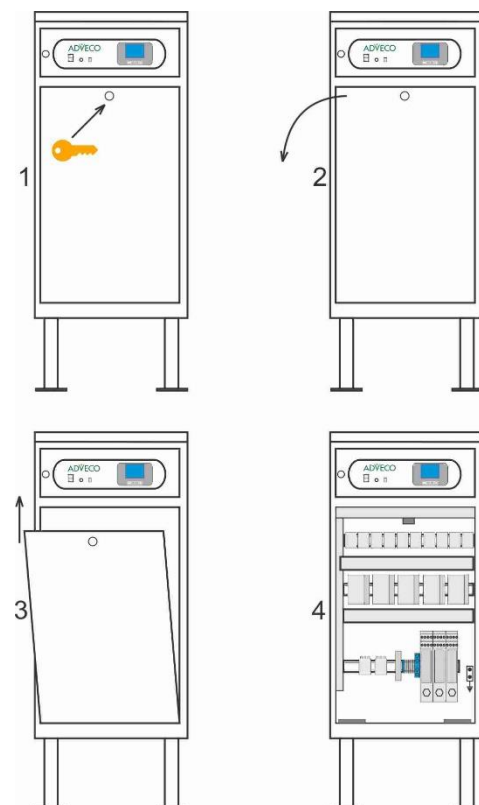

**Image 4:** De-mounting switchboard door

## 4.4 Boiler mounting

This chapter describes the installation of the boiler.

- The boiler is designed for floor mounting with minimum distances (Image 3)
- Make sure that the boiler is standing upright
- If necessary, attach the boiler to the floor using anchor screws (adequate for floor type)

## 4.5 Hydraulic connections



**NOTE:** Material damage caused by the installation of connecting lines!

- ▶ Install the connecting lines without connecting them to the boiler connections

Connect the lines of the heating installation as follows:  
Connect the return line to the return line of the boiler.  
Connect the supply line to the boiler thrust line

## 4.6 Filling the installations and watertight testing

### 4.6.1 Filling the boiler with heating water and sealing test

It is necessary to check the tightness of the boiler before commissioning.



**DANGER:** Injuries and/or material damages can occur with overpressure when testing watertight!  
High pressure can damage regulatory and safety devices and reservoir.

- ▶ After filling with water set the boiler on pressure that is equal to the opening pressure of safety valve
- ▶ Comply with maximum pressure of installed components
- ▶ After testing sealing, open again closing valves
- ▶ Make sure that all pressures, regulatory and safety parts work correctly



**DANGER:** Health threat due to mix of drinking water!

- ▶ Be sure to comply with national regulations and standards to avoid mixing with drinking water (eg with water from a heating installation)
- ▶ Comply with EN 1717



**NOTE:** Material damage caused by temperature changes.

- ▶ If you fill the boiler in a warm state, temperature changes can cause cracks due to stress and the boiler will start to leak water
- ▶ Only fill the boiler in cold condition with a maximum supply temperature of 40 °C)
- ▶ Only fill the boiler through the valve on the pipeline (return line) of the boiler



**NOTE:** Damage to the installation due to poor water quality!

Depending on the characteristics of the water, the installation of the heating system can be damaged by corrosion or by the formation of scale.



**Image 5:** Pressure value displayed

- Follow the requirements for water for filling according to VDI 2035, i.e. project documentation and the catalog
- Check the expansion vessel pre-pressure in the system
- Slowly fill the boiler via the fill and drain tap. Keep an eye on the pressure rise on the display (Image 5). When operating pressure is reached, close the tap
- The boiler is vented via a valve on the thrust pipe
- Venting the boiler results in a decrease in operating pressure, so water must be added
- Perform tightness testing according to local regulations
- After you have tested for leaks, open any elements that you have closed for filling
- Make sure all safety components are working properly
- If the boiler has been tested for leakage and no leakage has been observed, set the pressure to the required value
- Remove the hose from the fill and drain tap
- Enter the operating pressure and water quality values in the operating instructions

### On first or repeated filling or when replacing water

- Comply with the water charge requirements

### 4.6.2 Heating pump air emission and de-blocking

This device does not have a circulation pump in it. When the external heating pump is blocked, overheating and switching off of the safety circuits in the boiler can occur.

**NOTE:** There is a flow switch installed on the boiler return line and connected electrically to block the operation of the heater if there is no water flow.

For normal boiler operation, the pump must be unblocked.

### 4.6.3 Boiler and installation air emission

This device has an automatic air vent.

An additional air vent for the pipe network must be installed on the installation.

## 5. Electrical connection



**DANGER:** Risk of life from electric shock!

- ▶ Electric works must be done only by qualified person
- ▶ Turn off voltage supply before opening device and secure it against accidental turn on
- ▶ Comply with assembly regulations



When connecting boiler on electric installation take care on connections scheme and connecting plans. Respect mandatory diameters of cables and fuses power outside the boiler



This device is manufactured for connection to three-phase power supply (3N ~ 400/230V 50Hz)

### 5.1 Connecting the boiler to the electrical grid

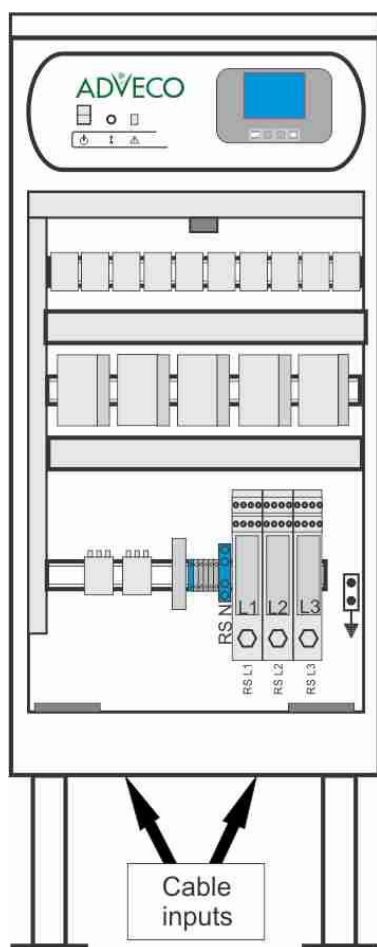

**Image 6:** Display of cable inputs positions

The boiler is connected to the mains voltage 3N ~ 400V 50Hz according to the applicable regulations. The protection against dangerous voltage should be done with a special protection line with a cable of appropriate cross section.

Power supply to the boiler must be done via the power supply cabinet. The power cabinet does not come as an integral part with the boiler. The designer of electrical installations must do adequate supply cabinet intended to supply the boiler. Power supply cabinet must be installed near the boiler with clearly visible indication that the boiler is switched on.

Table 3 shows the minimum cross sections of the power cables as well as the protective (PE) lines. Power is provided using Cu cables.

By using power cables with the recommended cross section, a minimum voltage drop to the boiler and a minimum of heating at the cable connection terminals is provided. A special rubber grommet is provided for the power cable as well as a cable clamp for attachment. The conductors from each cable are connected to the regular terminals according to the diagram (Figure 7).

The circuit breakers are equipped with remote voltage triggers that respond to the safety thermostat signal so that they have the function of safety elements (see section 7), that is, safety circuits that disconnect the device from electricity in case of temperature rise above the maximum allowed value of 95 °C.

Opening the boiler door and accessing the switchboard with boiler automatics are only allowed to a qualified person. Before opening these doors, turned off the main switch on the terminal box and the main fuses installed in the terminal box.

3N ~ 400/230V 50Hz	Standard S 70kW	Standard S 80kW	Standard S 90kW	Standard S 100kW
<b>In[A]</b>	3 × 101,5	3 × 116	3 × 130	3 × 145
<b>Main fuses [A]</b>	3 × 125	3 × 125	3 × 160	3 × 160
<b>Min. cable cross-section</b>	Cu 3×50mm <sup>2</sup>	Cu 3×70mm <sup>2</sup>	Cu 3×70mm <sup>2</sup>	Cu 3×70mm <sup>2</sup>
<b>Min. cross-section PE lines</b>	Cu 1×25mm <sup>2</sup>	Cu 1×25mm <sup>2</sup>	Cu 1×35mm <sup>2</sup>	Cu 1×35mm <sup>2</sup>

**Table 3:** Rated current, required main fuses and cross section of the required power cables for a 70 ÷ 100kW boiler

## 5.2 Connecting power (voltage) cable

Make the connection according to the assembly diagram (Image 7).

Power cables are connected to the RSL1, RSL2, RSL3 (phase conductors) terminal blocks.

Auxiliary terminal blocks are provided for the connection of the remote control signal and the pump command signal.



**ATTENTION!** When connecting the phase conductors, be sure to tighten the screws in the regular terminals in order to achieve the best possible connection between the conductors and the terminals.



**DANGER!** If the connection between the conductor and the terminal is not good, the terminal may overheat and break



**NOTE!** Connecting this device must be performed by a person qualified to do this type of work

## 5.3 Scheme for connecting power (voltage) cable

The neutral (zero) supply connects to the connect clamp (RSN). Connecting clamp of neutral (zero) supply is blue.

Connect the protective earth conductor (PE) to the screw marked with a grounding mark.

- RSP10 and RSP11 - terminals intended for connecting a circulation pump, or the contactor that starts the circulation pump. They have a voltage of 230V AC ( $I_{max} = 2A$ ) when the microcontroller allows the pump to operate.

- RSP12 and RSP13 - terminals intended for connecting the operation of the boiler according to external conditions (remote start/stop). Sends a voltage of 230V 50Hz from the boiler to the relay with voltage-free contacts at the Room Thermostat or BMS, or any remote control device.



**NOTE:** These clamps are Factory-made short-circuited (RSP 12 and RSP 13). Before connecting external working conditions, remove this short connection

- RSP14 and RSP15 - clamps of the voltage-free contact system of the Fault Relay, for failure signaling to the monitoring and control system, or connecting the audio or visual signaling of the boiler fault.

- RSP16 and RSP17 auxiliary terminal clamps (OPTIONAL) are provided to connect the outdoor temperature sensor (TSS). It is mounted on the north side of the building, in the zone protected from atmospheric influences (sun, rain, snow, ...) and connects to RSP16 and RSP17 terminal clamps using two-wire conductor with cross section min  $2 \times 0,5mm^2$  (AWG20), maximum length 20m.

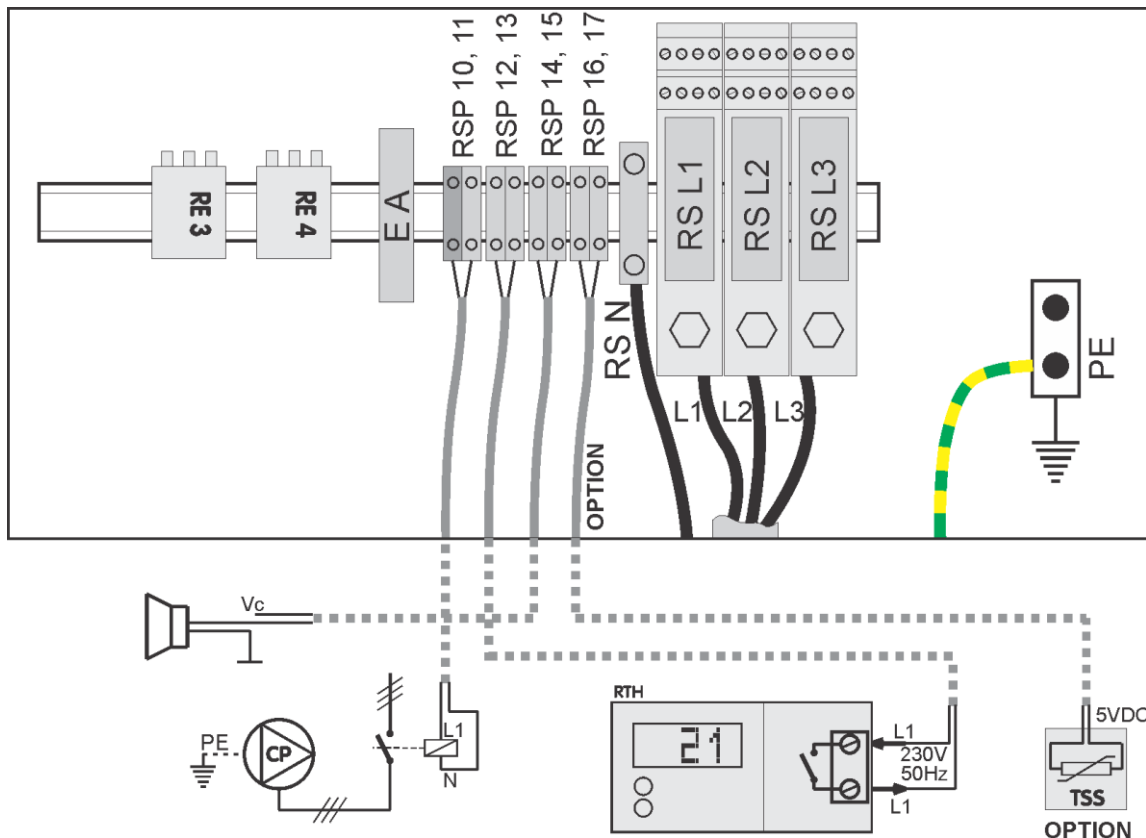

**Image 7:** Connection diagram of power cables, circulation pump and remote on / off signals

## 5.4 Electrical schemes



All cable cross sections listed are minimal. The size of the cable cross section to be set depends on the length and method of installation

- Dimensions of the cable cross-section should be sized according to local regulations

Legend	
<b>RSL1, ..., RSL3</b>	Power cable terminals (70/5 × 10mm <sup>2</sup> )
<b>RS N</b>	Neutral (zero) cable connection clamp (35mm <sup>2</sup> )
<b>E1 ÷ EX</b>	Three-pole circuit breaker (MCB), C25A (C40A – for a 100kW boiler)
<b>DNO1 ÷ DNOX</b>	Remote voltage trigger (shunt trip release) mounted on MCB (E1 ÷ EX)
<b>RE3</b>	Safety relay – activates by a signal from the Safety thermostat and initiates a shunt trip release (upgraded to E1 ÷ EX) that turn-off MCBs, and cuts off the boiler power supply.
<b>RE4</b>	Fault Relay (Voltage-free contacts)
<b>K1 ÷ KX</b>	Contactors BENEDICT K3-10ND10 (I <sub>th</sub> =25A) / SIEMENS Sirius 3RT2016 (I <sub>th</sub> =22A)
<b>RS G1 ÷ RS GX</b>	Heater terminal clamps (10mm <sup>2</sup> )
<b>G1 ÷ GX</b>	Heater 10kW (3×3333W) Three-phase tubes; Tied in " star "
<b>EA</b>	Control circuit single pole circuit breaker (MCB B6A)
<b>ST</b>	Safety thermostat – in case of boiler overheating (over it 95 °C) activates RE 3
<b>P1</b>	Boiler switch (ON/OFF) on the dashboard
<b>RSP1 ÷ RSP9</b>	CPU Power terminals , sensor connection and safety thermostat connection (4mm <sup>2</sup> )
<b>TS</b>	Temperature Sensor KTY81-110 (connected to RSP6 and RSP7)
<b>TSS (OPTIONAL)</b>	Outdoor temperature sensor KTY81-110 (connected to RSP16 and RSP17)
<b>SP</b>	Pressure sensor (connected directly to CPU)
<b>FS</b>	Flow sensor (Flow Switch) connected to RSP8 i RSP9
<b>RE2</b>	Flow Switch Relay - transforms the flow switch signal from 230VAC to 5VDC
<b>RSP10 ÷ RSP11</b>	Terminals intended for a circulation pump command (230V AC; 2A)
<b>RSP12, RSP13</b>	Terminals of external condition for boiler operation – Remote start/stop of the boiler (voltage of 230VAC is sent to the relay with potential free contacts e.g.: RTH – Image 7)
<b>RSP14, RSP15</b>	Terminals of Voltage-free contacts of the fault relay
<b>RSP16, RSP17 (OPTION)</b>	External temperature sensor terminals (sensor is placed in a box for outdoor use IP67)
<b>UR</b>	External condition for boiler operation, e.g.: room thermostat (RTH) or any other remote control device with a voltage-free contact system
<b>RE1</b>	Remote start/stop relay, transforms the remote start/stop signal from 230VAC to 5VDC
<b>ZT</b>	Safety thermostat for switchboard 40 °C - NO / 90 °C - NC
<b>MP</b>	Power supply board – Generates voltages of 8V DC and 24V DC for power supply
<b>OS1</b>	Electric fuse of the primary circuit of the transformer (T500mA)
<b>OS2</b>	Electric fuse of the pump control circuit (T2A)
<b>OS3</b>	Electric fuse of the secondary circuit 24V of the transformer (T500mA)
<b>OS4</b>	Electric fuse of the secondary circuit 8V of the transformer (T500mA)
<b>Re P</b>	Circulation Pump Voltage Command Relay (on MP pcb)
<b>Re MV</b>	Command Relay (on MP pcb) which activates Fault Relay (RE4)
<b>EK_CPU_1_3</b>	Microprocessor thermoregulator board
<b>Re1, Re2, Re3</b>	Contactors relays on the PLR1 board (PLR_V3B)
<b>Re4, Re5, Re6, (Re7)</b>	Contactors relays on the PLR2 board (PLR_V3B / PLR_V4)
<b>Re7, Re8, Re9, (Re10)</b>	Board contactors relays PLR3 (PLR_V3B / PLR_V4)

**Table 4:** Legend of Advenco Standard connection scheme for power 70 ÷ 100kW

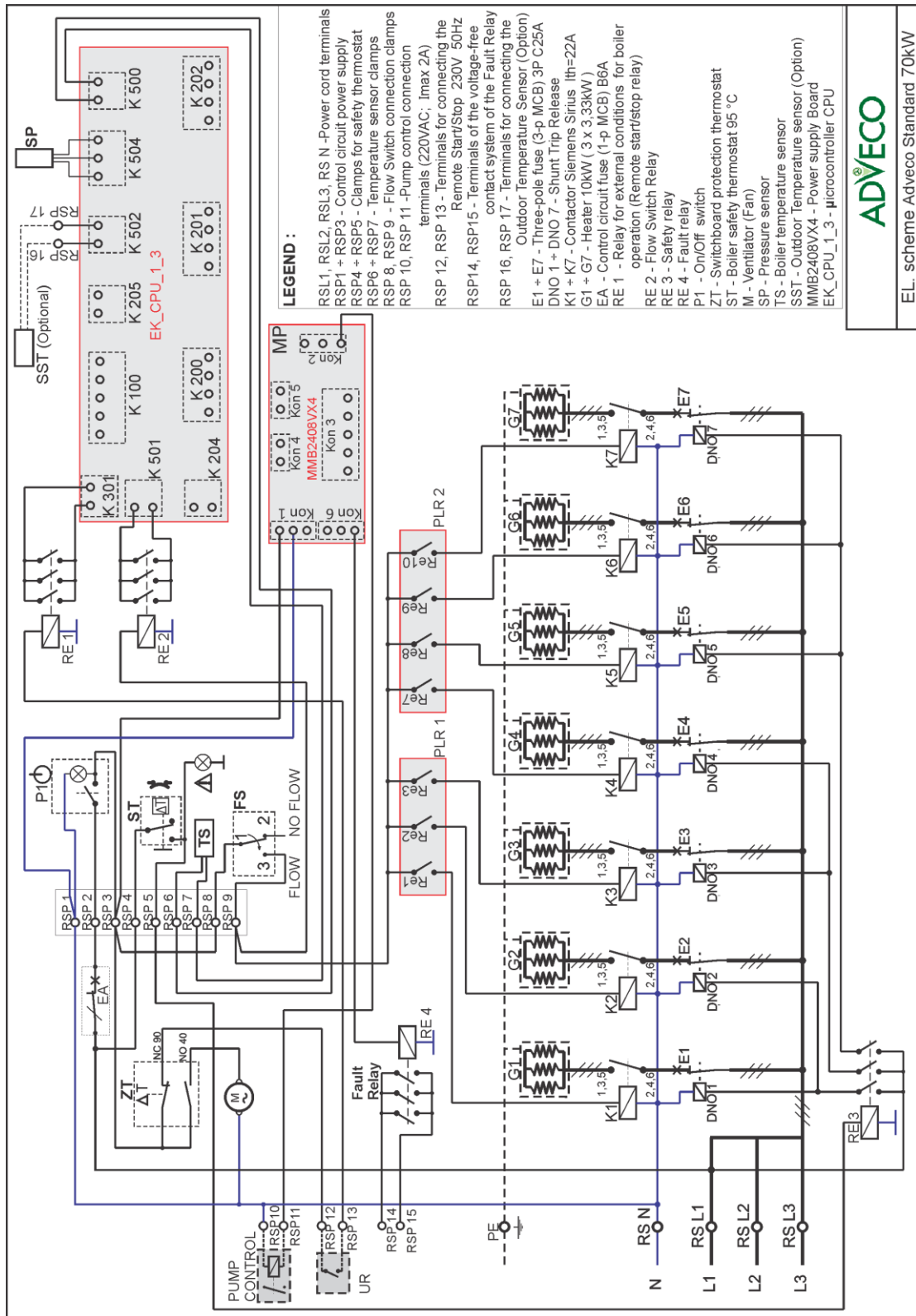

Example: El. scheme for boiler 70kW

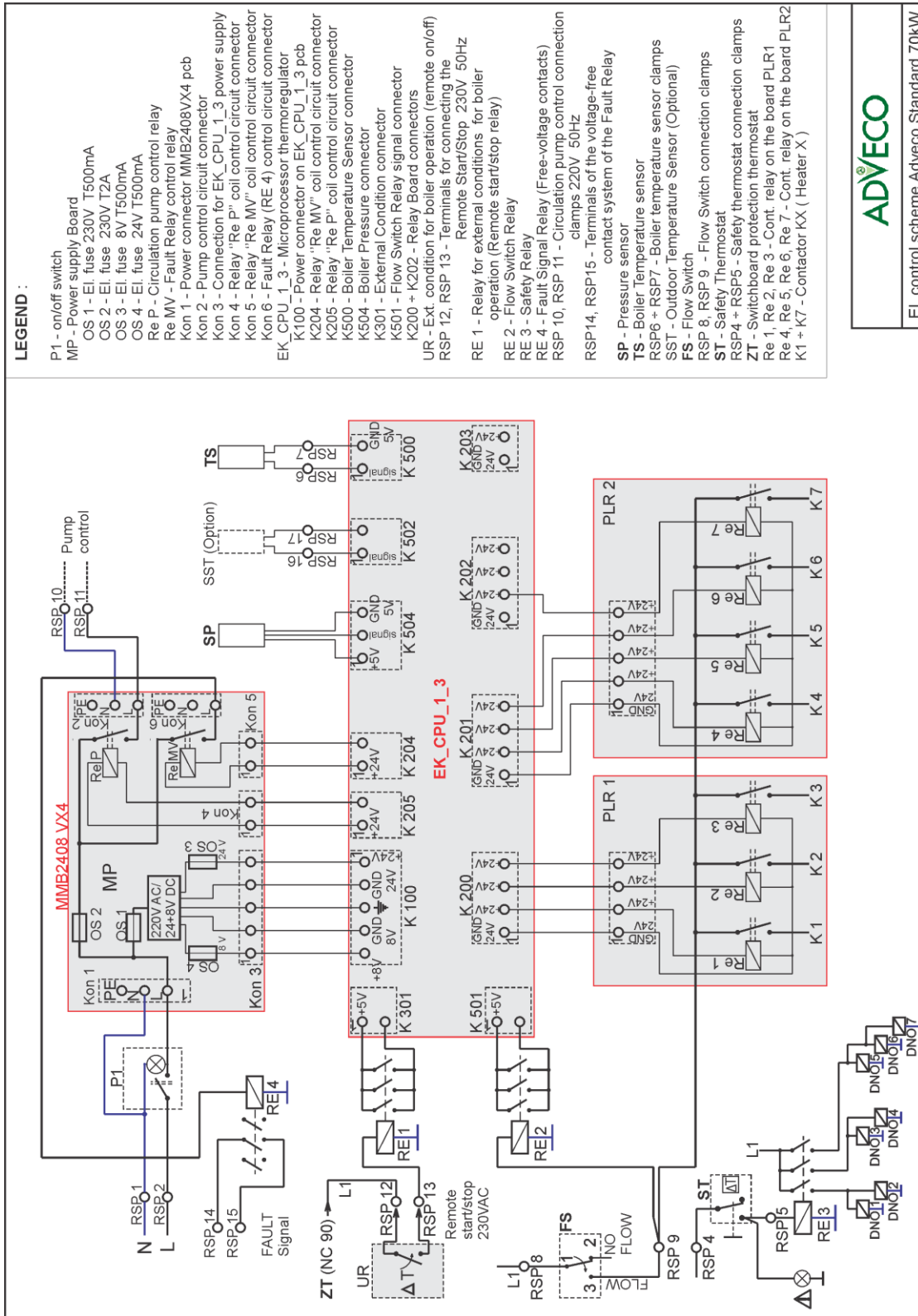

**ADVECO**

EI. control scheme Adveco Standard 70kW

**Example:** EI. control scheme for 70kW boiler

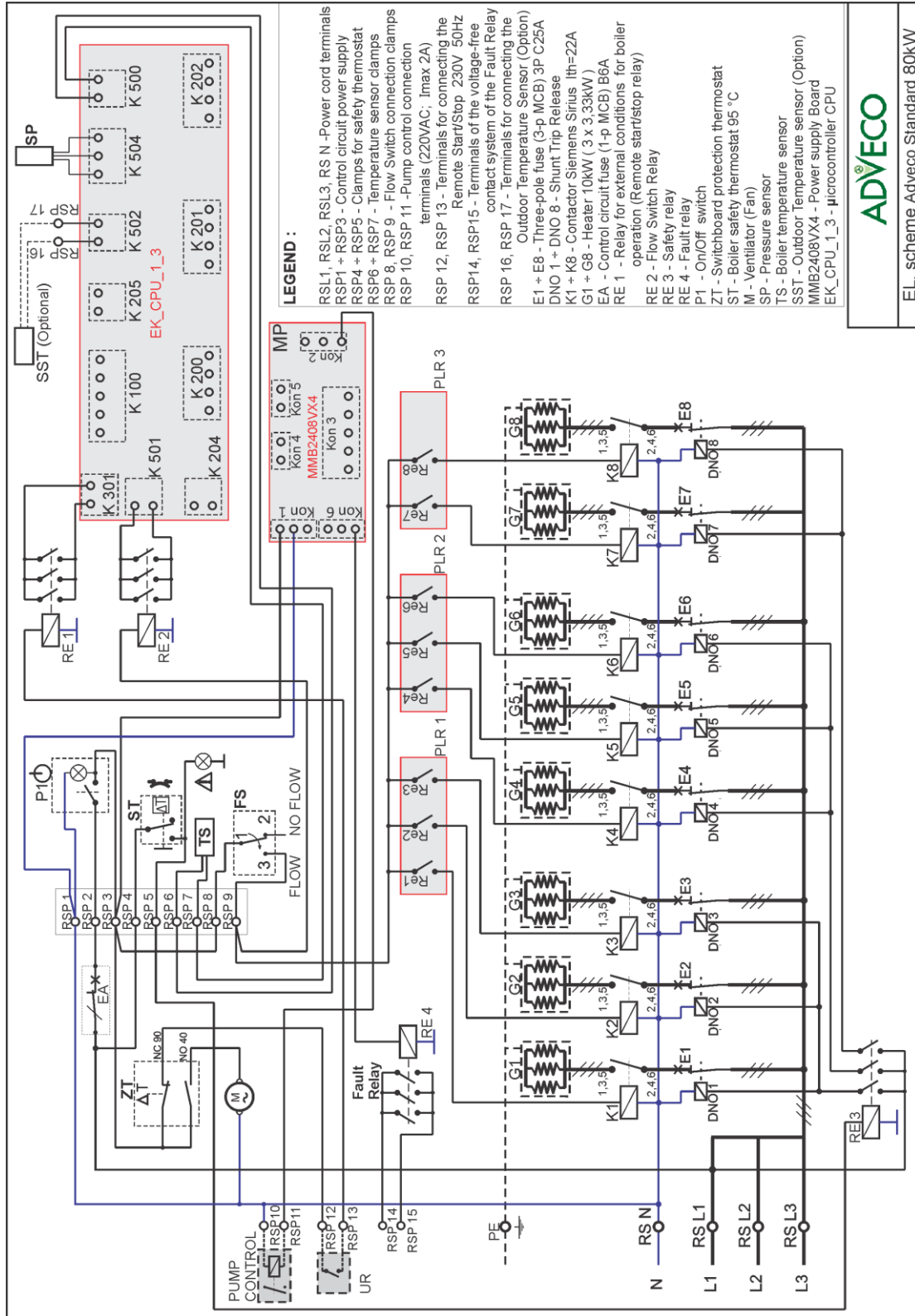

EL. scheme Adveco Standard 80kW

Example: El. scheme for boiler 80kW



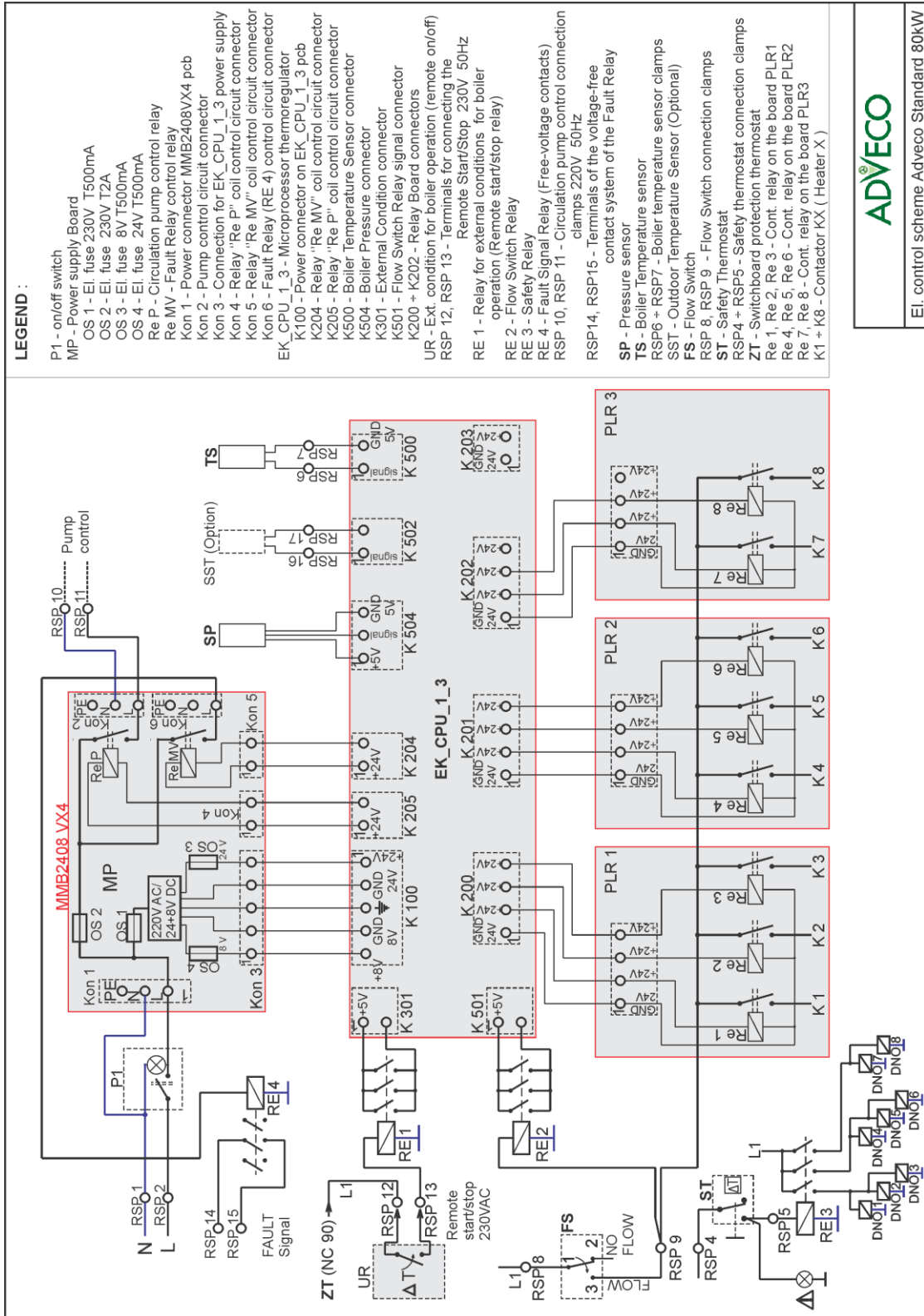

**ADVECO**

EI. control scheme Advenco Standard 80kW

**Example:** EI. control scheme for 80kW boiler

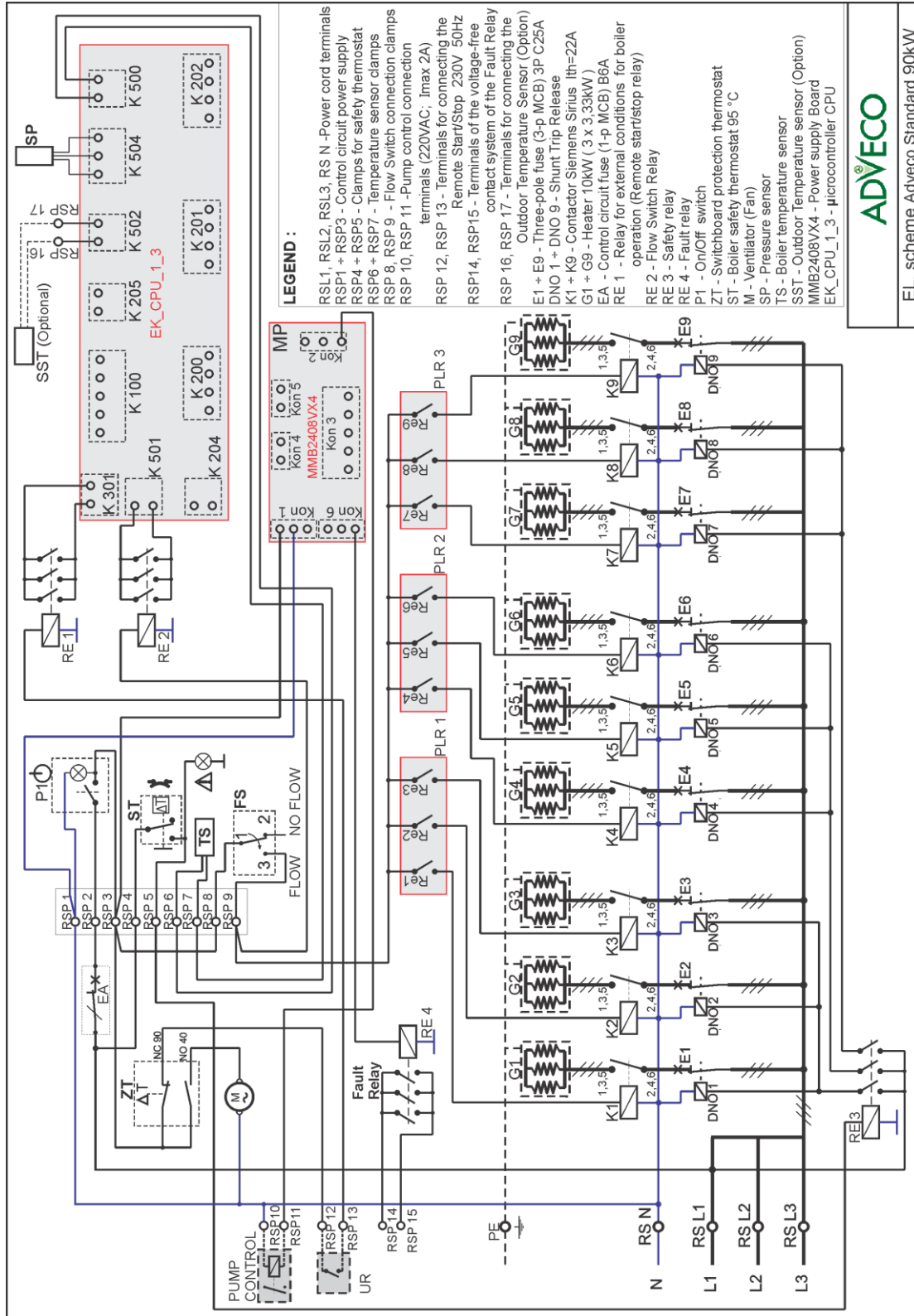

**ADVECO**

EL. scheme Adveco Standard 90kW

**Example:** El. scheme for boiler 90kW

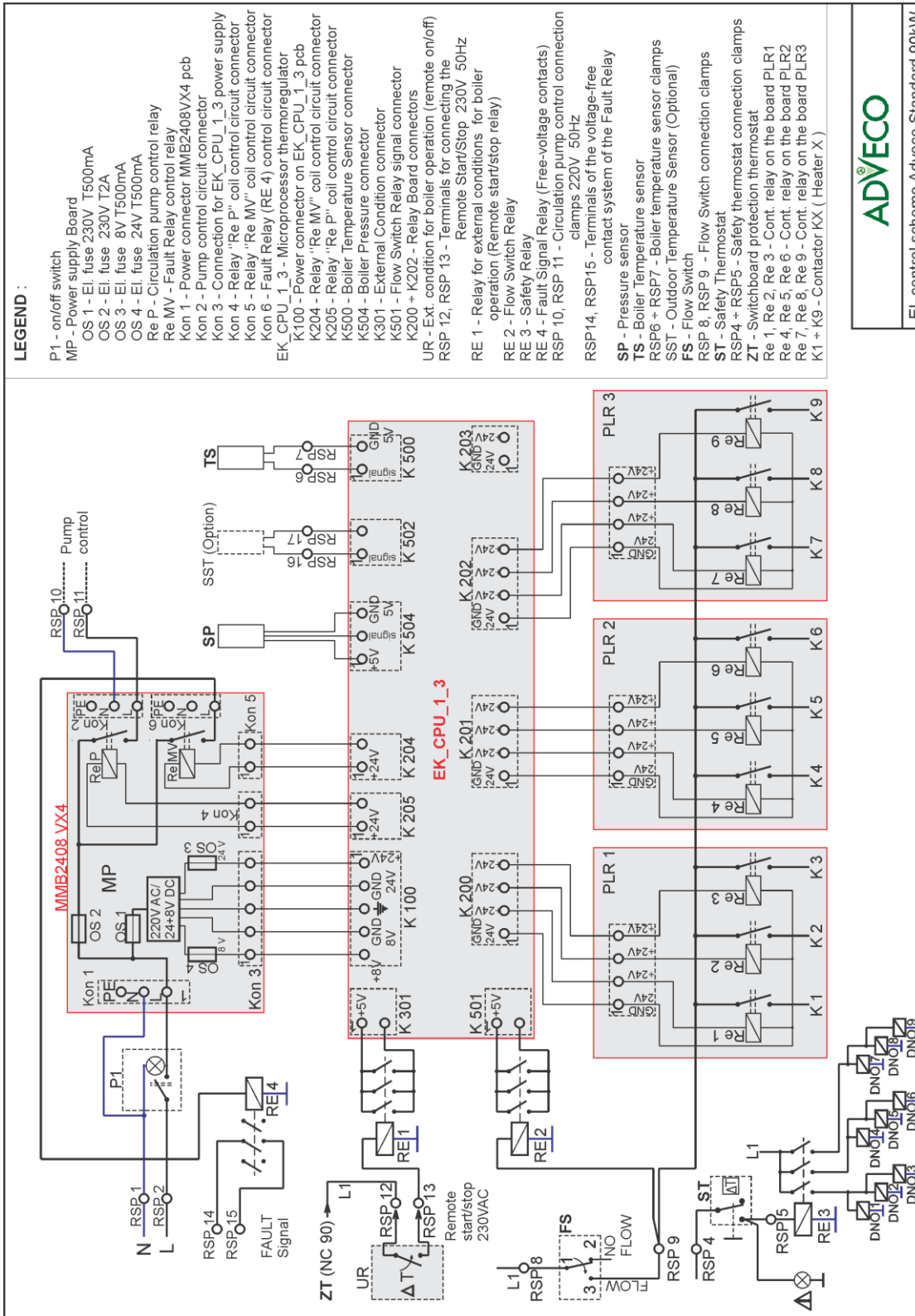

EI. control scheme Advenco Standard 90kW

Example: EI. control scheme for 90kW boiler

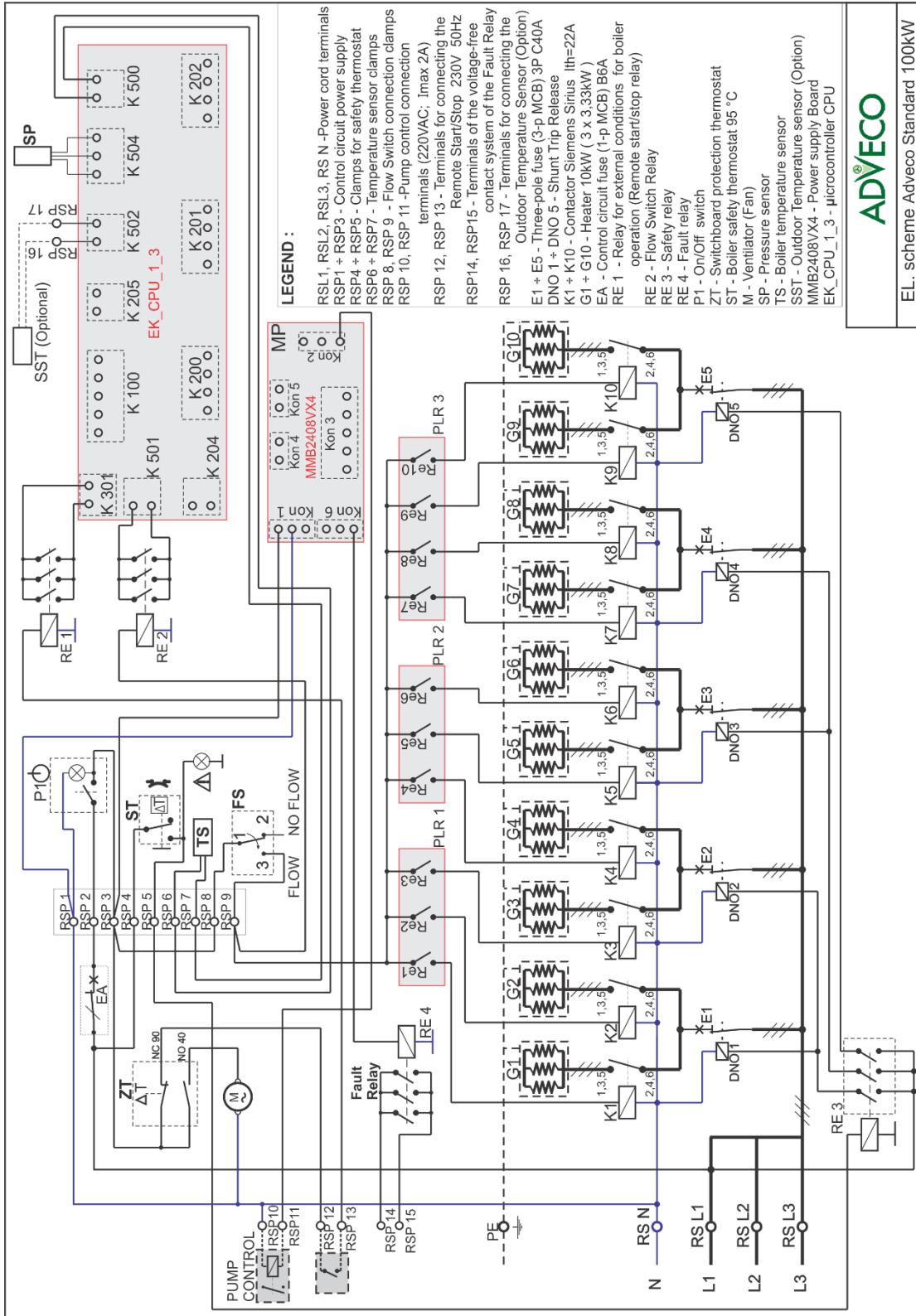

**ADVECO**

EL. scheme Adveco Standard 100kW

**Example:** El. scheme for boiler 100kW

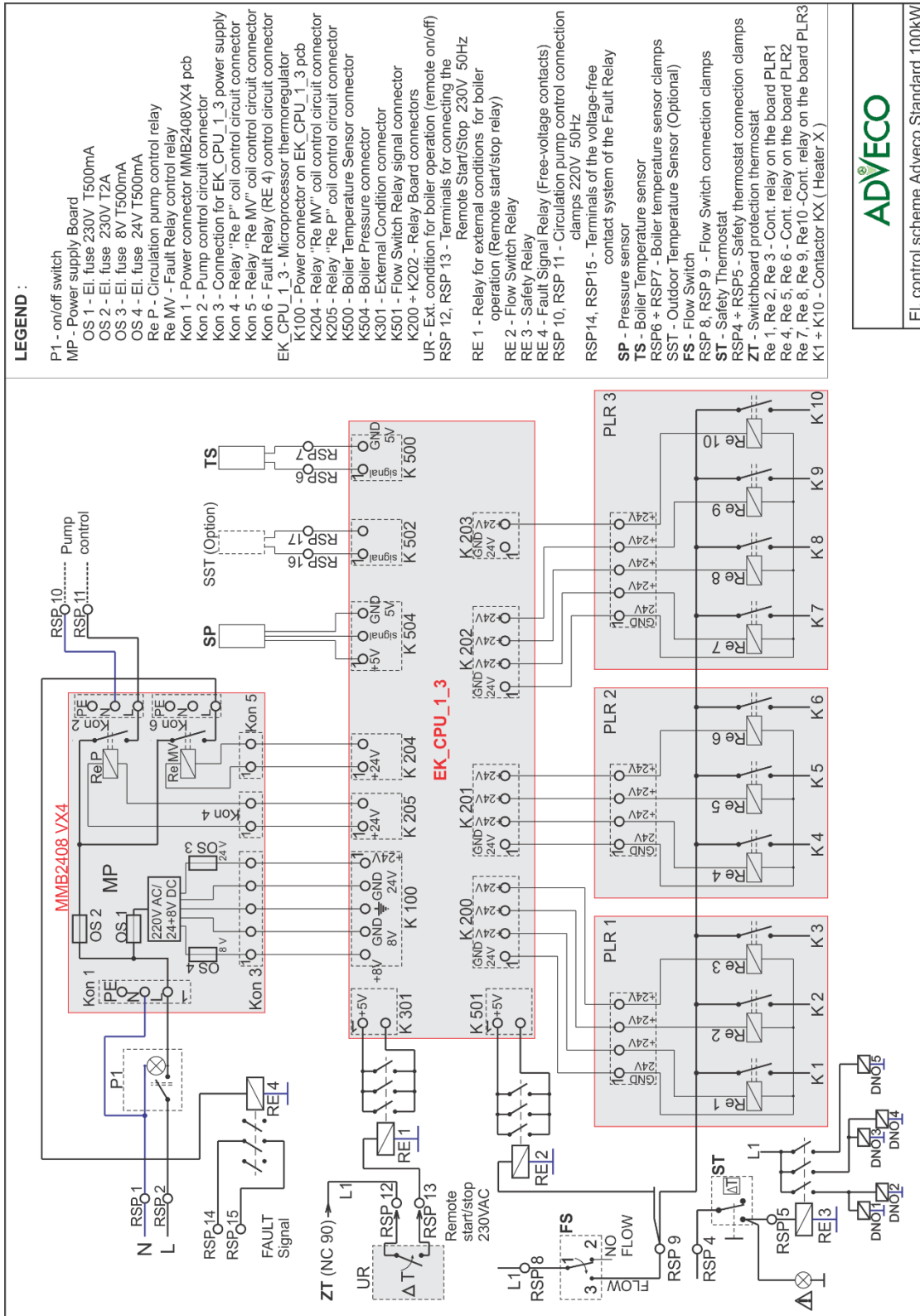

Example: El. control scheme for 100kW boiler



El. control scheme Adveco Standard 100kW

## 6. Commissioning

When complete below described works fill in the Commissioning log (chapter 6.4).

### 6.1 Before commissioning



**NOTE:** Material damage occurred due to unprofessional operating!  
Start-up without sufficient quantity of water destroys device

- ▶ Turn on the boiler and use it only if there is sufficient quantity of water



Boiler must work with minimum pressure of 0.8 bars

Before commissioning, make sure that the following elements and connections are properly connected and working properly:

- All pipes and valves and other system elements
- All electrical connections
- Leakage of heating installation

### 6.2 First start



**NOTE:** Material damage due to incorrect handling!

- ▶ Instruct client/user how to handle device

Before commissioning for the first time, make sure that the heating installation is filled with water and vented

- Turn on the main switch (on the dashboard)
- Switch on the circulation pump of the heating system
- Adjust the set power of the heater
- Adjust the operating temperature with the thermostat

### 6.4 Start-up log

1.	Boiler type	
2.	Serial number	
3.	Set thermostat regulation	<input type="checkbox"/>
4.	Fill and air-vent heating installation and check sealing of all connectors	<input type="checkbox"/>
5.	Establish working pressure	_____ bar
	Check expansion dish pressure	_____ bar
6.	Test safety devices	<input type="checkbox"/>
7.	Set electric connection according to local regulations	<input type="checkbox"/>
8.	Test function	<input type="checkbox"/>
9.	Users informed, technical documentation submitted	<input type="checkbox"/>
10.	Notes	
11.	Certificate of professional turn on device	Service seal / Signature / Date

### 6.3 Setting the Flow Switch "Caleffi 626600"

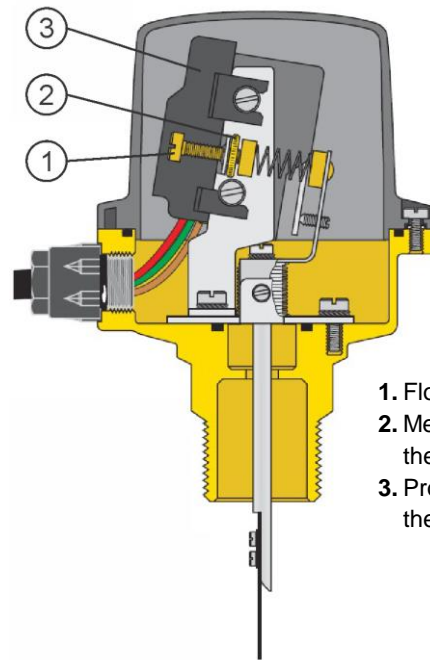

1. Flow adjusting screw
2. Metal ring for fixing the adjusting screw
3. Protective cover of the contact system

In order for the heaters to be switched on, the circulation pump must be switched on, i.e., the Flow Switch must detect the flow through the boiler and only then allow the boiler to operate.

If there is no flow through the boiler, or insufficient to activate the flow switch - flow sensor turns off control circuit and does not allow the contactors to be switched on. Error information (E5) will appear on the CPU display (→7.2.4).

Flow at which the Flow Switch is activated (switches on by microswitch) can be adjusted using a screw - position 1 in the figure above. The minimum and maximum flow rates required to activate the microswitch are given in the table below.

Activation range of Flow switch "Caleffi 626600"				
Connector dimension DN50 (2")	Min.		Max.	
	Flow reduction	Increase in flow	Flow reduction	Increase in flow
[l/min]	37	50	110	112
[m³/h]	2,2	3	6,6	6,7

## 7. Operation of the device

### 7.1 Safety instructions

- The boiler can only be operated by adults who are familiar with the boiler's instructions and operation.
- Do not leave or store easily flammable objects within a safety distance of 400mm around the boiler.
- Flammable objects must not be placed on the boiler.
- The user must adhere to the operating instructions.

### 7.2 Overview of controls and protection elements

#### 7.2.1 Boiler control panel



1. ON / OFF switch - Turn on the device
2. Safety thermostat (switching off the device at 95 ° C)
3. Alarm signal lamp (boiler faults)
4. Microprocessor Temperature Controller (CPU) - Device operation management. Constantly displayed setpoints and current values of temperature, pressure and power.
5. Buttons - Communication with the user device:
  - Boiler temperature selection in the range of 10 ° C ÷ 90 ° C,
  - Boiler power selection

#### Symbols that may appear on the display

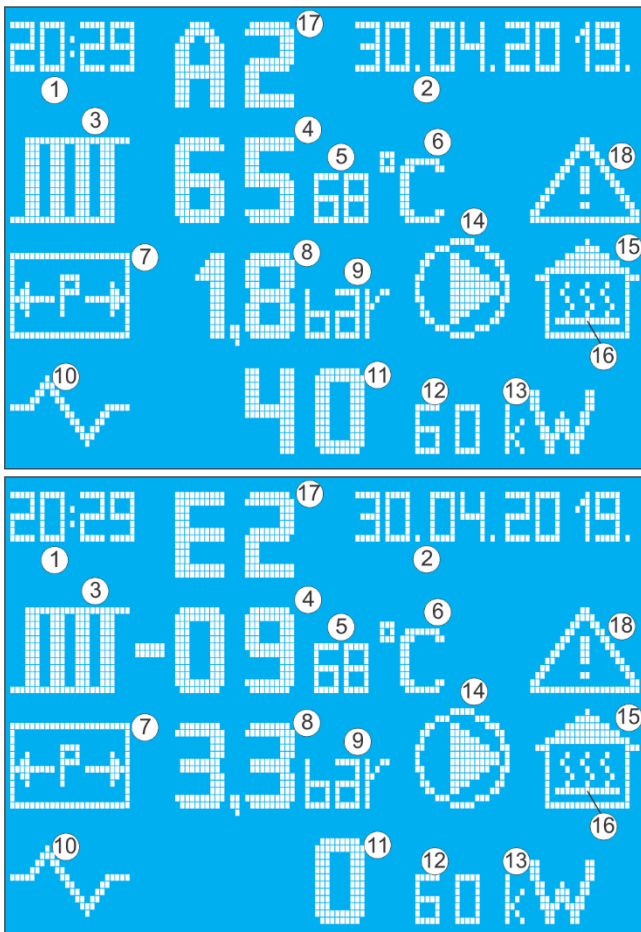

1. Time
2. Date
3. Radiator symbol (current and set system temperature are displayed on the right side of the symbol)
4. Current temperature (possible display - 99 ÷ 120 ° C)
5. The temperature (can be displayed from 10 to 90 ° C)
6. Temperature unit symbol (° C)
7. Pressure vessel symbol (current system pressure is displayed on the right side of the symbol)
8. Pressure in the system (Can display from 0 to 4,3bar)
9. Pressure unit symbol (bar)
10. Electric power symbol (current and set boiler power are displayed on the right side of the symbol)
11. Current boiler output in kW
12. Set boiler output in kW
13. Symbol measurement unit of electrical power (kW)
14. Circulation pump symbol (appears when thermoregulator sends a command voltage to activate pump relay)
15. The symbol of the space that is heated (house)
16. Remote start signal symbol (boiler operation allowed)
17. Warning symbol (A1 - A4) or errors (E0 - E9)
18. Danger symbol - Appears when pressure or temperature values approach or find themselves outside the permitted range, as well as in the event of a fault in the boiler operation for some other reason.

## 7.2.2 Modes of operation

The boiler can operate in manual mode when the set temperature is manually adjusted, or OPTIONAL in OTC (Outdoor Temperature Compensation) mode, when the microcontroller determines the required system temperature according to one of two operating curves set in the settings or maintains a constant temperature which is also specified in the OTC mode settings

## 7.2.3 Manual mode

Symbols on the screen when the boiler is in manual mode

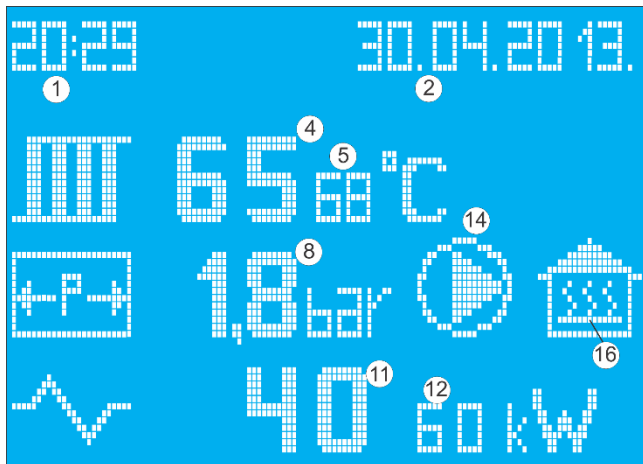

1. Time
2. Date
4. Current thrust line temperature
5. The set temperature on boiler thrust line
8. Current pressure in the boiler
11. Current engaged power
12. The set power
14. Pump operation information - if the pump symbol is on the display, (CPU gave a signal to activate the pump), means that the auxiliary terminals of RSP 10 and RSP 11 have a voltage of 230V 50Hz, which can be used to start the circulation pump, or the contactor that powers the circulation pump
- 16.- Information on the status of external working conditions, i.e. remote control (start / stop signal) - If the symbol is on the display, boiler operation is allowed

User communication with the device is facilitated and improved by displaying all system parameters on a graphical LCD and by simple command with four keys.

The operating temperature is set in steps of 1°C, and it is possible to set the value from 10 to 90 °C.

Boiler output is set in steps of 10kW, e.g. 7 ÷ 10 heaters are available, power per 10kW.

After 3 minutes of the last key press the display illumination is reduced to 10% of normal. By pressing any key returns to normal illumination.

## 7.2.4 The principle of operation in manual mode

Temperature and hydraulic pressure sensors monitor changes in the system and send information to the microcontroller (CPU) which processes them and controls the operation of the boiler based on them. Also, the microcontroller constantly receives information about the status of the start / stop signal, i.e. the external conditions for boiler operation.

For the device to work normally, the pressure and temperature must be within the permitted limits.



It is necessary for the heaters to be switched on that the circulation pump is switched on, i.e. the Flow Switch must detect the existence of flow through the boiler and only then allow the heater to work in the boiler.

The Flow Switch is electrically connected to interrupt the contactor control circuit if no flow through the boiler is detected. It can happen that the CPU has a signal for remote switching on, based on it it turns on the pump relay, but if the impeller of the pump is e.g. mechanically blocked - flow through the boiler will not exist. In this case, the flow sensor represents an interruption of the heater contactor control circuit and does not allow the relay and contactor or heater to be switched on. Also, information from the flow sensor is sent to the CPU, so the error information (E5) will appear on the CPU display, which is automatically canceled when the water flow through the boiler is established and the flow indicator detects it, which takes ≈3s. This error (E5) can also occur if the flow through the boiler exists, but is not sufficient to activate the flow indicator. In this case, the flow indicator (Flow Switch setting range →6.3) or pump power must be set).

The pump can be controlled by a signal from the boiler that switches it on when it receives a signal of external operating conditions (remote switching on using a room thermostat or any other device). After the boiler is switched off remotely, the pump continues to run for another 2 minutes (due to the removal of heat energy dissipated from the still hot heaters immediately after switching off), after which it is switched off.

The CPU also switches on the pump in case of overheating, when the boiler temperature exceeds 90 °C regardless of the status of the external operating conditions.

The pump can also be controlled externally, so that it is switched on before or simultaneously with the remote switching on of the boiler, i.e. the external operating conditions

Switching the heater on and off is successive, with a distance of 3sec between each heater, with the division of the engaged power into 3 parts (3 heating groups), temperature shifted by 3 °C.

Heating groups are formed by a microcontroller based on the operating time of each heater - there are no fixed heaters that form a heating group. The microprocessor (CPU) decides on the heaters that will form the heating group each time it is switched on, by first selecting the heaters with the shortest operating time. This achieves an even distribution of the operating time of each heater, which results in a longer service life of the device as a whole.

In the event that the pressure or temperature approaches impermissible values, warning codes (→7.3.5) appear on the display.

In the event of a boiler malfunction, the microcontroller takes measures to protect the device from damage (blocks the heater, switches on the pump relay if necessary), and the error codes that appear on the display (→7.3.5).



### 7.2.5 Setting temperature



By briefly pressing the " SET " button, it enters the mode for setting the temperature and the set power. By briefly pressing the " SET " button, it enters the mode for setting the temperature and the set power. The setpoint value of the boiler temperature begins to flash, which can now be enlarged or reduced with the buttons " ^ " and " v ".

Each push of a button increases or decreases set boiler temperature by one °C.

In order for a change to be remembered, it must be confirmed by pressing the " OK " button, which also switches to power adjustment.

If the change is not confirmed after 15sec from pressing any button (except OK), thermostat continues to operate at the previously specified value temperature and exits the setting.

The set temperature range is 10 to 90 °C. The set power is always divided into 3 heating groups, for example:

default **70kW**:

**group 1:** 3 × 10kW

**group 2:** 2 × 10kW

**group 3:** 2 × 10kW

The boiler operates with an engaged power equal to the given one, until the current temperature approaches 6°C to the set temperature when the third heating group is switched off. The boiler continues to operate at less than the set value (third heating group excluded) until the current temperature approaches 3°C to the set temperature, when the second heating group is switched off.

The boiler operates with an engaged power equal to the given one until the current temperature approaches 6°C to the set temperature, when the third heating group is switched off.

The boiler continues to operate at less than the set value (third heating group excluded) until the current temperature approaches 3°C to the set temperature, when the other heating group is switched off. In the last area (temperature by 1, 2, or 3 °C lower than the set point) the boiler only works with heating group no. 1, until the set temperature is reached. If the power is not enough, the temperature will decrease causing the heating group 2 to be switched on again. The heating groups are formed by a microcontroller according to the measured operating times of each heater, so the group is not always made up of the same heaters, and all heaters are evenly loaded.

### 7.2.6 Setting power

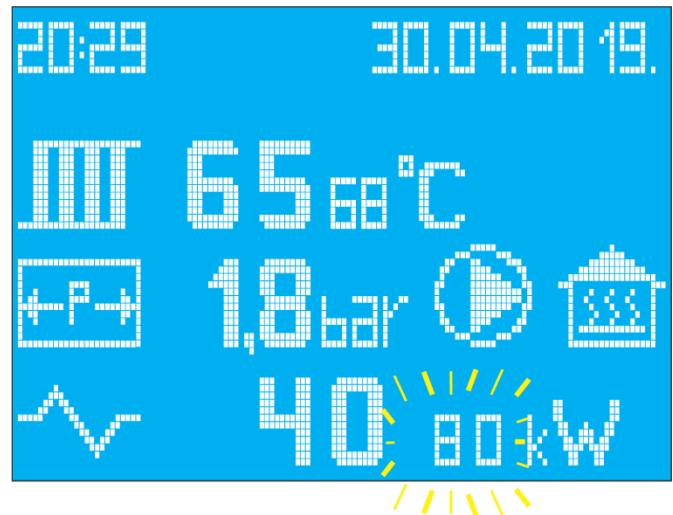

If a change is confirmed after setting the temperature (presses OK), the thermostat switches to power setting - flashing set power. If you don't want to change the temperature but just the power, during normal display, press the 'SET' key. When the temperature starts to flash, press " OK " and proceed to the boiler power setting.

The setpoint value of the boiler output begins to flash, which can now be enlarged or reduced using the " ^ " and " v " buttons. Each press of the " ^ " button increases given power by one step (10kW), and every pressure to the " v " button decreases the boiler power by one power step.

Selected power values are:

0kW, 10, 20, 30, 40, ... rated power,

In order for the change to be accepted, it must be confirmed by pressing the OK button, which is the exit from the setting. If the change is not confirmed, after 15sec of pressing any key, the thermostat resumes operation at the old setpoint value and exits the adjustment mode. In the course of work, the engaged force will be equal to the given one until the current temperature approaches the set temperature, and then the engaged power decreases, that is, the heaters are gradually switched off, thereby saving energy and precisely reaching the set temperature.

### 7.2.7 Setting time and date

To set the time and date, press and hold " SET " continuously for 3 seconds. The TIME begins to blink which can now be changed. In order for the change to be accepted, it must be confirmed by pressing the " OK " button. If the change is not confirmed after 15 seconds of pressing any key (except " OK "), the thermostat will continue operating in the old time.

If the change is confirmed, the DATE flashes - the setup process is the same.

### 7.3 OTC (Outdoor Temperature Compensation) Boiler Operation Mode (OPTIONAL)

In this mode, the microcontroller determines the required system temperature according to one of the two operating curves set in the settings, or maintains a constant temperature also set in the settings for the OTC mode.

#### 7.3.1 Choice of boiler operating mode

Press the "OK" key for 5 seconds to enter the mode selection. The following display will appear on the display:



- MANUAL - Manually adjust the temperature of the system
- O. T. C. (Outdoor Temperature Compensation) - the temperature of the system depends on the outside temperature, calculates the microcontroller according to one of the given operating curves.

The initial factory setting is that the boiler is in manual mode.

'MANUAL' blinks, and on the right sides stands the check mark (✓). Later, during operation, flashes the mode that is currently active.

The  and  buttons select the desired mode of operation, and the check mark (✓) moves next to the selected mode.

Pressing the button 'SET' accepted mode that flashes (where the sign is ✓) and returns to the basic display

Image 8: Mode selection (Manual or OTC)



Image 9: Manual mode selection

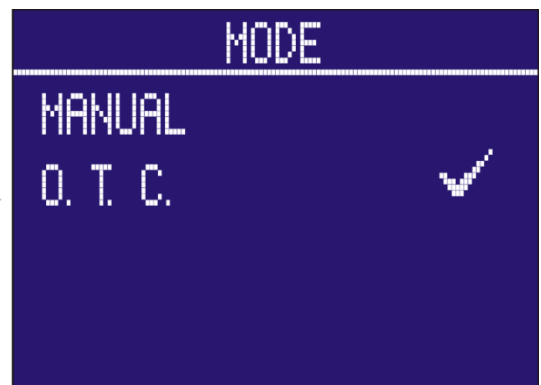
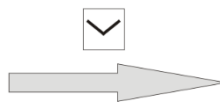

Image 10: O.T.C. mode selection

If the O.T.C. is selected mode and then press the OK button - the OTC mode menu opens (Image 11), in which the adjustments required must be made for keeping the temperature according to external conditions:



Image 11: O.T.C. mode menu

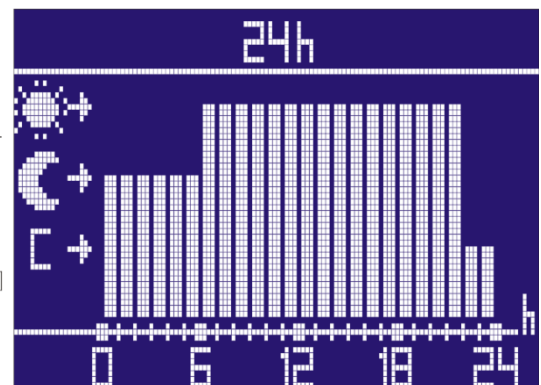
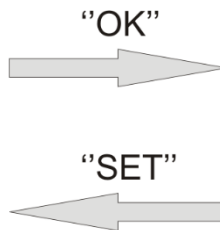

Image 12: 24-hour programming in O.T.C. mode

### 7.3.2 24-hour programming

To set 24 hour programming press "OK" when there is a sign ✓ next to it (Image 11). A display (Image 12) appears on the display, at which the desired operating curve or const must be selected for each hour from 0 to 24. temperature. At the beginning of the setting, the bar for the period 0 ÷ 1h flashes. Use the ⬆ and ⬇ buttons to select:

- a) Comfortable working curve - a symbol of the sun;
- b) Economic labor curve - symbol of the month;
- c) Constant Temperature - Const. for that period.

By pressing the 'ok' button switches on the setting for the next hour: 1 ÷ 2 h. The procedure is repeated for each successive period of one hour and confirmed by pressing the "OK" button, which switches to the setting for the next hour.

In the example of Image 12, the following setting is selected:

- 0 ÷ 6h The boiler is operated at outside temperature according to economical labor curve (Moon ☾)  
The factory setting of this operating curve is adapted to night mode - a lower room temperature is required and therefore lower system temperature.
- 6 ÷ 22h The boiler is operated at outside temperature according to comfortable working curve (Sun ☀)  
The factory setting of this operating curve is adapted to the daily mode - higher room temperature is required and therefore higher system temperature.
- 22 ÷ 24h The boiler maintains a constant temperature defined during setting for "Const".  
The factory setting for this temperature is 50 °C.

After completing the settings for the entire 24h period, confirmation and memorization of the set parameters is done by pressing the "SET" button, which returns the display to the OTC mode menu display (Image 11).

### 7.3.3 Adjusting the working curve

For adjustment of the curves in O.T.C. mode, when the OTC mode menu is displayed (Image 11), use the ⬆ and ⬇ buttons to select the operating curve you want to adjust (the sign ✓ should be next to it), and then confirm with "OK". As an example, the setting of a comfortable working curve (indicated by the sun symbol ☀) is explained:

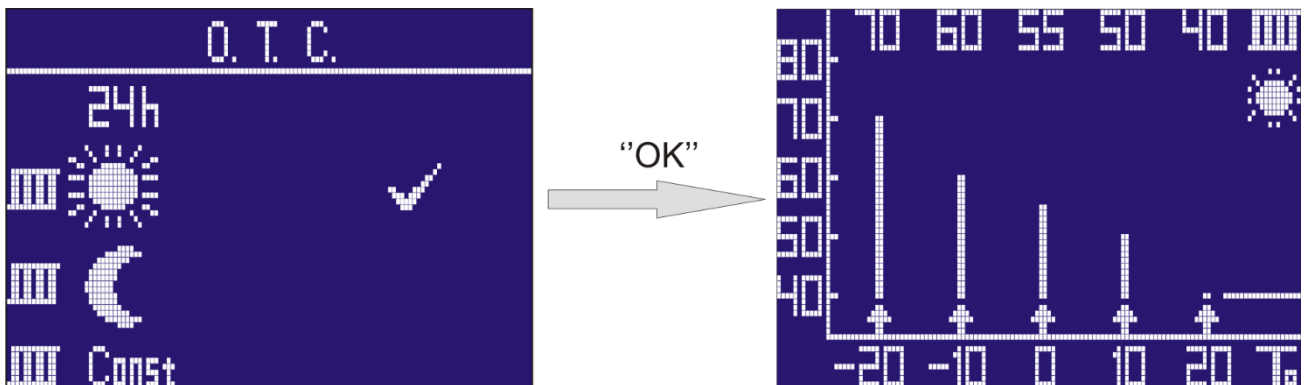

Image 13: Adjusting the comfort curve (☀)

5 reference points of outside temperature ( $T_o$ ) are given: -20, -10, 0, 10, 20. For each of them, the boiler temperature should be set, at that outside temperature:  $T_k(-20)$ ,  $T_k(-10)$ ,  $T_k(0)$ ,  $T_k(10)$  and  $T_k(20)$ .

At the beginning of the setting, the arrow above the outside temperature value -20 °C and the boiler temperature value  $T_k(-20)$  to be set for this outside temperature (70 °C in this example) blinks. The positions of all digits are fixed. Each press of the ⬆ button increases the set boiler temperature by 1 °C, which is indicated by changing the flashing digits and changing the number of cubes in the vertical bar. Pressing the ⬇ button decreases the set temperature by 1 °C. Pressing the "OK" button - moves to the next reference point, and pressing the "SET" button confirms and returns to the OTC mode menu.

- The range of setting the boiler temperature for the point -20 °C is:  $T_k(-20) = 40\text{ °C} \div 80\text{ °C}$ .
- The range of setting the boiler temperature for point -10 °C is:  $T_k(-10) = T_k(-20) - 10\text{ °C} \div T_k(-20)\text{ °C}$ , resp. the minimum temperature that can be set for the reference point  $T_k(-10)$  is 10 °C lower than the set point for the previous point, and the maximum that can be set is identical to the temperature set for the previous point, in this case it is  $T_k(-20)$ .

The same restrictions apply to other settings. This ensures that labor rights have a proper appearance and that the slope of labor rights is not too high.

The division of the areas:

Outside temperature: -50 °C to -11 °C (including -11): line equation defined by points  $T_k(-20)$  and  $T_k(-10)$  with max. allowed temp. 80 °C. Eg. if for an outside temperature of -25 °C calculated value of required system temperature 86 °C, the boiler will interpret this as a maximum of 80 °C.

Outside temperature: -10 °C to -1 °C (including -1): The line of equations defined by the points  $T_k(-10)$  and  $T_k(0)$ .

Outside temperature: 0 °C to 9 °C (including 9): The line of equations defined by the points  $T_k(0)$  and  $T_k(10)$ .

Outside temperature: 10 °C to 19 °C (including 19): The line of equations defined by the points  $T_k(10)$  and  $T_k(20)$ .

Outside temperature: 20 °C to 50 °C fixed temperature equal to the set point  $T_k(20)$ .

After the adjustment of the operating curve is completed, confirmation and memorization of the set parameters is done by pressing the "SET" button, which returns the display to the OTC mode menu (Image 11).

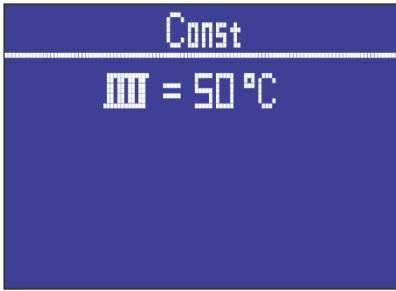

The same way is for entering submenu and setting for an economical work curve (C). To adjust the Constant Temperature (**Const**) value in the O.T.C. mode, use the  $\Delta$  and  $\nabla$  button to select (**Const**) (the sign  $\checkmark$  should be next to it), then confirm with the "OK" button. The following display opens on the display (Image 14). The factory setting of this temperature is 50 °C, and a value in the range of 10 ÷ 80 °C can be set. When the settings are completed, confirmation and memorization of the set parameters is done by pressing the "SET" button, which returns the display to the OTC mode menu (Image 11).

**Image 14:** Setting the constant temperature for OTC mode

Example of setting up and going through the menu:

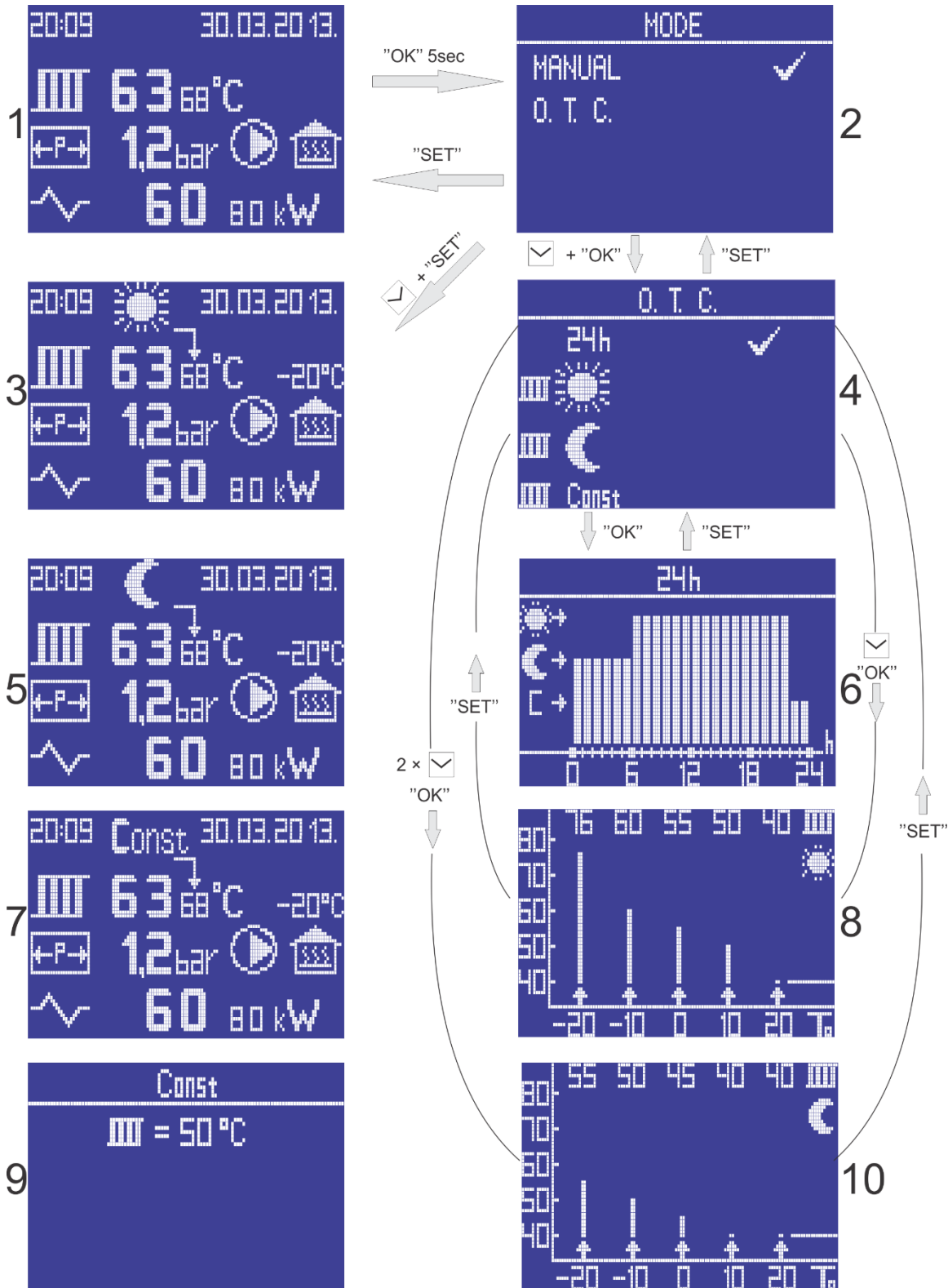

7.3.4 Symbols on display in OTC mode

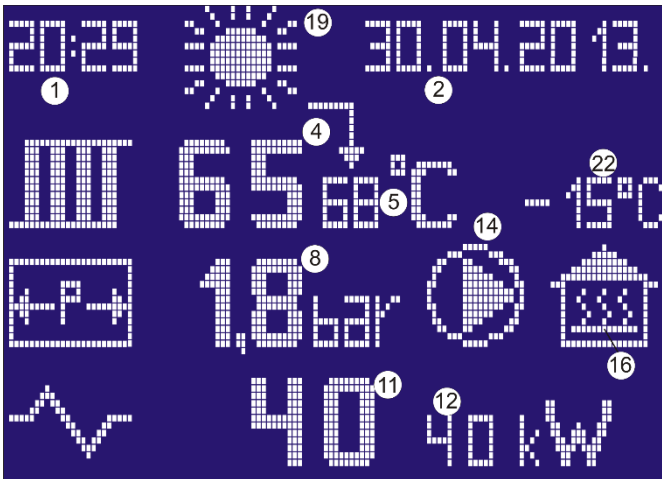

19 Sun symbol: The boiler operates in OTC mode, and currently, according to daily (24-hour) programming, thrust line temperature is calculated according to the operating line for a comfortable system temperature (indicated by the sun symbol ☀).

20 Moon symbol: The boiler operates in OTC mode, and currently, according to daily (24-hour) programming, thrust line temperature is calculated according to the operating curve for the economical temperature of the system (symbol of moon ☾).

21 "Const": The boiler operates in OTC mode, and currently, according to daily (24-hour) programming, thrust line temperature is not calculated according to operating curves, but has a constant value set in the OTC settings.

22 Current outdoor temperature (can be displayed from -50 to 50 °C)



### 7.3.5 Warnings and errors

- A1** Pressure below 0.8 bar: The boiler operates normally up to 0.4 bar and the alarm signal lamp blinks.  
Recommendation: Fill the system to a pressure above 0.8 bar
- A2** Pressure above 3.5 bar: The boiler operates normally up to 3.5 bar and the alarm signal lamp blinks.  
Recommendation: Drain water to keep pressure below 3.5bar
- A3** Temperature below 5 °C: The boiler operates normally until the temperature drops to 2 °C and the alarm signal lamp blinks.  
Recommendation: check the functionality of the device
- A4** Temperature above 80 °C: The boiler operates normally until the temperature rises to 85 °C and the alarm signal lamp blinks.  
Recommendation: check the temperature sensor, contactors, valves and piping
- E0** Problem with eeprom memory: CPU does not have valid initial data - device operation blocked.  
Recommendation: Turn off the power to your device and call for service, CPU replacement is probably required.
- E1** Pressure below 0.4 bar: Heaters and pump relay switched off (after 2 minutes)  
Recommendation: Refill the system to a pressure above 0.8 bar and the boiler will automatically resume operation according to the predefined power and temperature values, without having to reset or re-adjust the parameters.
- E2** Pressure above 4.0 bar: Heaters and pump relay switched off (after 2 minutes)  
Recommendation: Drain the water to a pressure below 3.5 bar and the boiler will automatically resume operation according to the predefined power and temperature values without having to reset or re-adjust the parameters.

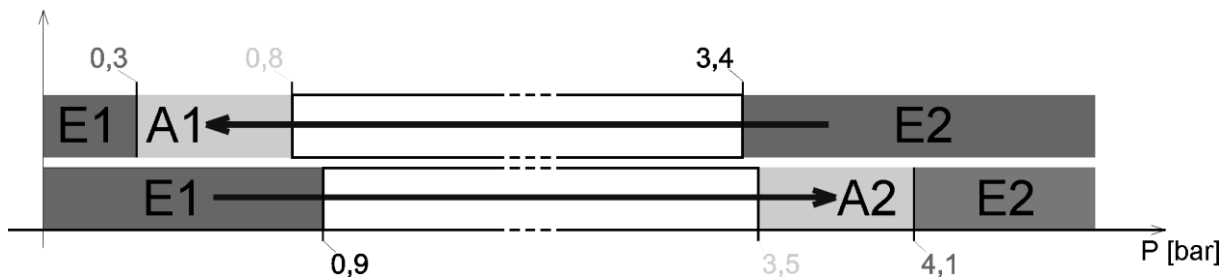

*Image 15: Warnings and errors caused by pressure*

- E3** Temperature equal to or below 2 °C: Pump and heater operation is not allowed due to the risk of some part of the system being frozen. The alarm signal lamp blinks.  
Recommendation: Turn off the power to the device and check the installation status
- E4** Temperature equal to or above 85 °C: Heater operation is not allowed due to the risk of overheating. The pump relay switches on (regardless of the status of the start signal) to turn on the pump and thereby reduce the boiler temperature (If the pump is operated externally, the signal from the CPU to turn on the pump has no effect.)  
Recommendation: Turn off the power of the device to check the functionality of the temperature sensor, contactors, valves and piping

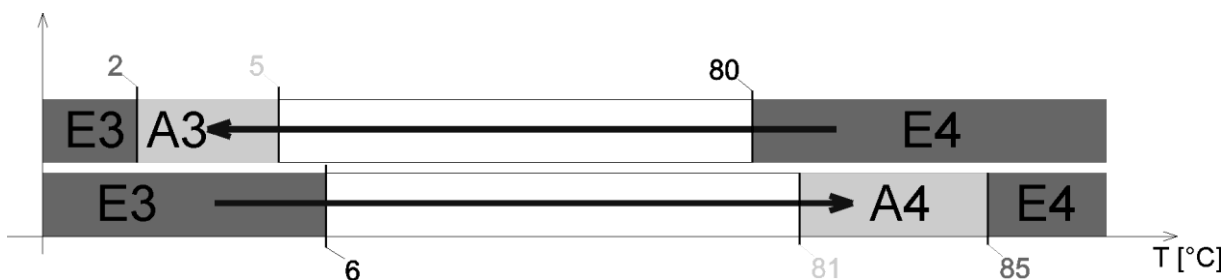

*Image 16: Warnings and errors caused by temperature*

- E5** If the flow through the boiler is reduced, or does not exist, that is detected by a flow switch - the operation of the heaters is disallowed.
- E6** Boiler or outdoor temperature sensor in interruption or short circuit: Heater operation is not allowed due to danger of overheating. The pump relay is also switched off.  
Recommendation: Turn off the power to the device to check the functionality of the temperature sensor.
- E8** Pressure sensor in interruption or short circuit: The heater is not allowed to operate due to the risk of overheating. The pump relay is also switched off.  
Recommendation: Turn off the power to the device, check the functionality of the pressure sensor.

## 7.4 Switchboard

### 7.3.6 Error and warning priorities

Multiple warnings and errors may occur at the same time during operation. Only one can be displayed, so the one with the highest priority will be displayed. After fixing it, an error with the next priority (if any) will be displayed.

List of priorities:

- E0** Problem with eeprom memory
- E6** Boiler or outdoor temperature sensor in interruption or short circuit
- E3, E4** Temperature outside permitted limits
- E5** The flow through the boiler is reduced, or does not exist
- E8** Pressure sensor in interruption or short circuit
- E1, E2** Pressure outside the permissible limits

### 7.3.7 Protective elements

In order for the heaters to be switched on, the circulation pump must be switched on.

A flow switch is installed on the boiler on the boiler return line, which is electrically connected as a condition in the control circuit which interrupts the control voltage of the contactor, i.e. does not allow the heater to switch on if it did not detect the existence of flow through the boiler. If the pump is on and there is water flow through the boiler, the contact system of the flow indicator is closed and the heaters can be switched on.

In addition to the electronic temperature sensor, which provides information to the thermostat, an independent safety capillary thermostat (ST) is mounted on the boiler. In the event of a temperature rise above 95 °C, it switches on the RE2 relay, which activates the voltage triggers superimposed on each three-pole circuit breaker, which results in the switching off of the automatic fuses, i.e. the complete failure of the power supply to the boiler. energy. To start the boiler again, the temperature in the boiler must be returned to normal, in order to be able to reset the safety thermostat (manual reset) and to enable the automatic fuses to be switched on manually. **Reactivation of the boiler must be carried out by an authorized person (servicer) as it determines the cause of the boiler overheating and corrects the fault if it exists.**

Another protective thermostat (ZT) is located in the automation of the boiler. When the temperature in the automatic part (boiler switchboard) reaches 40 °C it switches on the fans for forced cooling of the switchboard environment, and if the temperature in the area where the automation is located rises above 90 °C turns off the control circuit voltage, which prevents the contactor and heater from switching on.

Short-term protection is provided by 3p C25A automatic fuses for each heater (3p C40A for 100kW boiler). The fuses are three-pole, so in the event of failure of any segment of the heater, they switch off the power of the complete heater (10kW). When replacing the fuse, be sure to install a fuse of the same characteristics.

Extreme protection against boiler pressure increase and heating installation is provided by safety valves with a nominal opening pressure of 4bar, mounted on the boiler thrust connection.

### 7.4.1 Arrangement of components on the switchboard

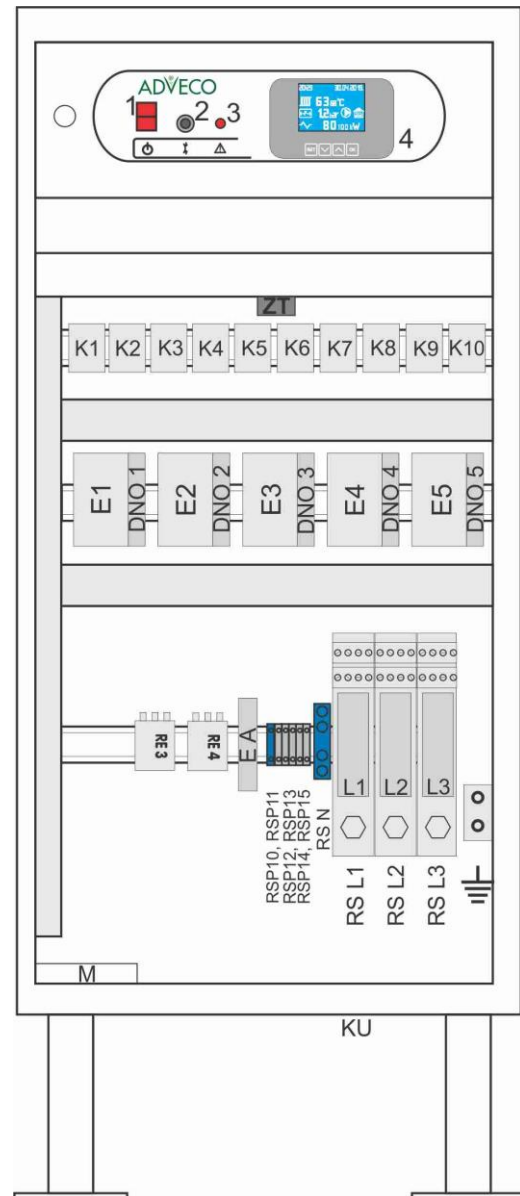
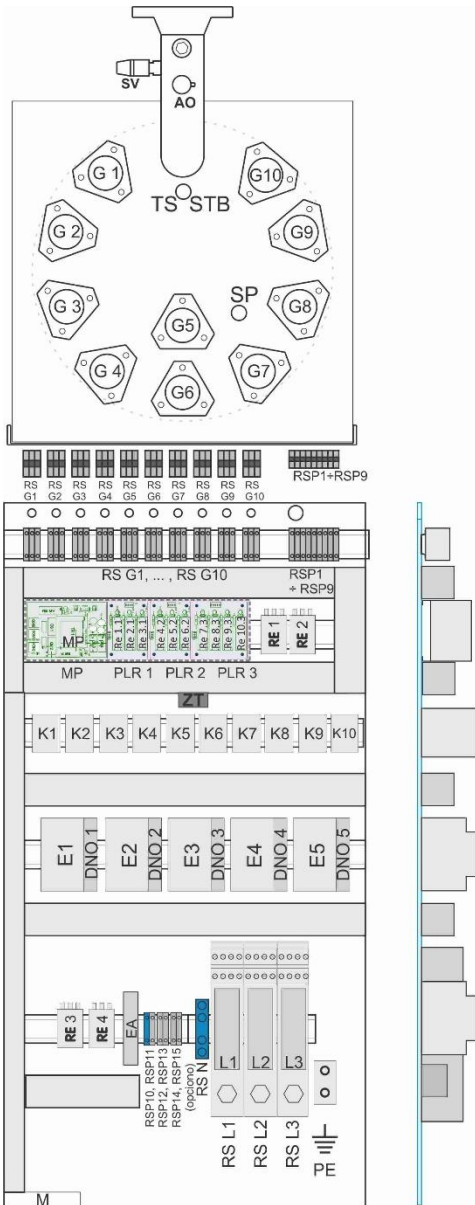

Image 17: Switchboard (100kW boiler example)

- RS L1 ÷ RS L3** Power cable clamps
- RS N** Clamp of neutral (zero) line
- RE 3** Safety relay
- RE 4** Fault relay
- RSP 10, RSP 11** Circulation pump control terminals: 230V; 50Hz; I<sub>max</sub> = 2A
- RSP 12, RSP 13** Terminals for external conditions for operation of the boiler 230V; 50Hz (Remote Start / Stop).
- RSP 14, RSP 15** Terminals of Voltage-free contacts of the fault relay
- E1, ..., EX** Three-pole circuit breaker with upgraded remote voltage triggers (shunt trip release)
- DNO1, ..., DNOX** Remote voltage trigger (shunt trip release)
- K1, ..., KX** Contactor
- E A** Control circuit fuse (1-p circuit breaker)
- ZT** Protective thermostat for boiler automatics
- KU** Cable entry
- M** Fan

### 7.4.2 Switchboard and the top plate of the boiler (100kW boiler example)



**Image 18:** Switchboard and top panel of the boiler (100kW boiler example)

- SV** Safety Valve ¾ " 4bar
- AO** Automatic Venting
- G1 ÷ GX** 10kW heater; Three-phase; connected in a star
- SP** Pressure sensor
- TS** Boiler temperature Sensor KTY81-110
- ST** Safety thermostat NO95 °C activation DNO1 ÷ DNOX (via RE3)
- ZT** Switchboard thermostat, switch on fan NO 40 °C and NC 90 °C heating blocking
- RS G1, ..., RS GX** Terminals for heater
- RSP 1, ..., RSP 9** Terminals for control circuit power, safety thermostat, temperature sensor and Flow Switch.

- RE 1** Remote start/stop relay, transforms the remote start/stop signal from 230VAC to 5VDC
- RE 2** Flow Switch Relay - transforms the flow switch signal from 230VAC to 5VDC
- RE 3** Safety Relay - activates by a signal from the Safety thermostat and initiates a shunt trip release (upgraded to E1 ÷ EX) that turn-off MCBs, and cuts off the boiler power supply.
- RE 4** Fault Relay (Voltage-free contacts)
- PLR1 ÷ PLR3** Relay Plate for switch on the Contactor Network Board - Power supply
- MP** EK\_CPU\_1\_3 and PLR
- K1, ..., KX** Contactor Benedict / Siemens (Ith = 22A)
- E1, ..., EX** Three-pole circuit breaker with upgraded remote voltage triggers (shunt trip release)
- RS L1 ÷ RS L3** Power cable clamps
- RS N** Clamp of neutral (zero) line
- EA** Control circuit fuse (1-p circuit breaker)
- RSP 10, RSP 11** Terminals for pump control
- RSP 12, RSP 13** Terminals for boiler operation by external conditions (Start / Stop signal)
- RSP 14, RSP 15** Terminals of Voltage-free contacts of the fault relay
- M** Fan

### 7.5 External condition for operation - Start / Stop signal

This device has the ability to be switched on or off remotely via: room thermostat, BMS monitoring and control system, or some other device. The temperature control of all rooms served by the heating system is controlled via this remote control. Radiators in the reference room should not be fitted with thermostatic valves, or they should always be open. All radiators in other rooms must be fitted with thermostatic valves. The connection of external conditions for boiler operation is shown in section 5.3.

### 7.6 Heating interruption

In the case of short-term interruption of the heating operation, the boiler temperature must be lowered by means of a thermostatic boiler controller. To prevent the installation of the heating system from freezing, the boiler temperature cannot be set below 10°C. In case of prolonged interruption of heating operation, the boiler must be switched off (Section 7.6.1).

#### 7.6.1 Putting the boiler out of operation

If the heating installation is not in operation, it could freeze at low temperatures.

- Protect the heating installation from freezing.
- If there is a risk of frost and the boiler is not in operation, empty the installation.
- Turn the main switch on the control panel to "0" (off).
- When the unit is switched off for a long time, the heating pump can be blocked (Section 4.6.2).



## 8. Cleaning and maintenance



**DANGER!** Life threat of electric power shock!

- ▶ Electric power work must be done only by qualified person
- ▶ Before opening device: turn heating installation off electric power supply using safety switcher and disconnect it from power supply net through corresponding fuse
- ▶ Secure heating installation against accidental turn on
- ▶ Comply with instructions for installation



**WARNING:** Material damage due to unprofessional maintenance!

Insufficient or unprofessional maintenance of boiler can lead to damage or destruction and to loss of Warranty rights

- ▶ Secure regular, entire and professional maintenance of heating installation
- ▶ Electric parts and work units protect against water and humidity



Use only spare parts delivered by the manufacturer or those approved by manufacturer. There will be no responsibility for damage occurred due to spare parts not delivered by the manufacturer



Control examination log is provided on chapter 8.4

- Perform works in accordance with log on control and maintenance
- All deficiencies remove immediately

### 8.1 Boiler cleaning

Clean this device externally with wet cloth

### 8.2 Check working pressure; re-fill water and air-vent installation



**DANGER:** Health threat due to mix of drinking water!

- ▶ It is demanding to respect state regulations to avoid mix of drinking water (with water from heating installations)
- ▶ Comply with EN 1717



Establish a working pressure of at least 1 bar, depending on the height of the highest point of the installation. If, due to the height of the installation, the operating pressure is greater than 1 bar (eg 1.5 bar) before the system is filled with water, it is necessary to lift the air intake in the expansion vessel to the same value - 1.5 bar

The volume of newly filled water is reduced in the first days after charging due to heating. This creates airbags that create interference in the heating system.

#### Testing working pressure

- Working pressure of new heating installation should control on daily basis at the beginning of its work. If needed, re-fill water and air vent the system
- Later check working pressure once per month. If needed, re-fill water and air vent the system
- Check working pressure. If it decreases below 1 bar re-fill water
- Re-fill the water
- Air vent the heating installation
- Check working pressure again

### 8.3 Re-fill the water and air-vent the installation



**WARNING:** Material damage due to heat tension. Filling heating installations in warm condition can produce cracks due to tension

- ▶ Fill heating installation only in cold condition (temperature of starting duct lines of max 40 °C)



**WARNING:** Material damage due to frequent re-filling!

Due to frequent water re-filling installations can be damaged by corrosion and carbonate layers depending on water characteristics

- ▶ Test sealing and watertight of heating installations and expansion dish on functionality

- Connect hose on water faucet
- Fill the hose with water and connect to connector for filling/drainage
- Tighten the hose and open the water faucet for filling/drainage
- Slowly fill the heating installation while following up with pressure (manometer)
- During filling procedure air vents the system
- When reach working pressure close the drainage faucet
- When reach working pressure close the drainage faucet
- Remove the hose from filling/drainage faucet

## 8.4 Inspection and maintenance log



At least once a year perform maintenance or when a check shows the status of installations that require maintenance

The commissioning, inspection and maintenance record serves as an attachment for copying

- Executed works should be authorised by signature and date

Inspection and maintenance works when needed		Date:	Date:	Date:
1.	Check condition of installations	<input type="checkbox"/>	<input type="checkbox"/>	<input type="checkbox"/>
2.	Visual and functional control	<input type="checkbox"/>	<input type="checkbox"/>	<input type="checkbox"/>
Making working pressure				
3.	• Check pre-pressure of expansion dish	<input type="checkbox"/>	<input type="checkbox"/>	<input type="checkbox"/>
	• Working pressure set on ... _____ bar	<input type="checkbox"/>	<input type="checkbox"/>	<input type="checkbox"/>
	• Heating installation air vent	<input type="checkbox"/>	<input type="checkbox"/>	<input type="checkbox"/>
	• Check safety heating valve	<input type="checkbox"/>	<input type="checkbox"/>	<input type="checkbox"/>
4.	Clean water filter	<input type="checkbox"/>	<input type="checkbox"/>	<input type="checkbox"/>
5.	Check if there is any damage on electric duct lines	<input type="checkbox"/>	<input type="checkbox"/>	<input type="checkbox"/>
6.	Check if electric control connections and used elements are fitted; tighten it if needed	<input type="checkbox"/>	<input type="checkbox"/>	<input type="checkbox"/>
7.	Check the functions of the microprocessor thermostat (CPU) on the boiler	<input type="checkbox"/>	<input type="checkbox"/>	<input type="checkbox"/>
8.	Check the function of the safety circuits (KP1, KP2, KP3 with built-in voltage triggers)	<input type="checkbox"/>	<input type="checkbox"/>	<input type="checkbox"/>
9.	Check remote control function (start / stop)	<input type="checkbox"/>	<input type="checkbox"/>	<input type="checkbox"/>
10.	Check the flow switch function	<input type="checkbox"/>	<input type="checkbox"/>	<input type="checkbox"/>
11.	Check the conductors and insulation of electric heaters	<input type="checkbox"/>	<input type="checkbox"/>	<input type="checkbox"/>
12.	Check function of grounding device	<input type="checkbox"/>	<input type="checkbox"/>	<input type="checkbox"/>
13.	Check heating pump function	<input type="checkbox"/>	<input type="checkbox"/>	<input type="checkbox"/>
14.	Make final control of inspection works and document results of measuring and inspecting	<input type="checkbox"/>	<input type="checkbox"/>	<input type="checkbox"/>
		Seal/Signature	Seal/Signature	Seal/Signature
15.	Certification of professionally conducted inspection			

**Table 5:** Inspection and maintenance log

## **9. Environment protection /Waste disposal**

One of the basic concepts of business is environment protection. Quality of products, thriftiness and environment protection are equally valuable goals for us.

It is critical to strictly comply with law and regulations on environment protection. In order to protect environment and respecting economy concepts we use only the best technique and materials.

### **Packaging**

Regarding packaging, we respect system of recycling which is specific in certain states and which secure optimal recycling

All materials applied for packaging do not harm environment and It is possible to recycle it.

### **Old devices**

Old devices contain valuable materials that can recycle. Structures are easily demountable and plastic materials are labeled. In such manner structures can be sorted and deliver for recycling.

---

## 10. Troubles and troubleshooting



Troubleshooting on regulations and hydraulics must be done by an authorised firm





For repairs use only original spare parts

TROUBLE	DESCRIPTION	CAUSE	MEASURE
<b>Boiler does not react after turn on of main switcher</b>	Display does not react, other components do not work	<ul style="list-style-type: none"> <li>Boiler is out of power supply</li> <li>Fuses on bottom plate are off</li> <li>Vanishing of managing phase</li> <li>Damage of main fuse ON/ OFF</li> </ul>	<ul style="list-style-type: none"> <li>Provide power supply</li> <li>Turn on fuses</li> <li>Check if fuses have three phases on output</li> <li>Change damaged part</li> </ul>
<b>Boiler does not heat or insufficiently heat / heating pump works</b>	All on display are within recommended values but boiler does not make hot water	<ul style="list-style-type: none"> <li>Lack of 1 or 2 phases</li> <li>Small power of boiler</li> <li>Some relay damaged</li> <li>Some heater damaged</li> </ul>	<ul style="list-style-type: none"> <li>Check all three phases</li> <li>Check set power of boiler</li> <li>Change damaged part</li> <li>Change damaged part</li> </ul>
<b>Boiler heats but it is very noisy</b>	Higher level of noise during work	<ul style="list-style-type: none"> <li>Air in the system</li> <li>Small water flow</li> <li>Possible carbonate layer on heater</li> <li>Worn contactor</li> </ul>	<ul style="list-style-type: none"> <li>Check if the system is air vented and vent it</li> <li>Check valves below boiler and open it</li> <li>Clean filter below boiler</li> <li>Take out heaters and clean it (this is not included in claims during warranty period)</li> <li>Change damaged part</li> </ul>
<b>Boiler turns on quickly</b>	Reaches temperature too quickly and turns on	<ul style="list-style-type: none"> <li>Valves below the boiler off</li> <li>Pump fuse stop to work</li> <li>Pump jammed</li> <li>Pump inaccurate</li> </ul>	<ul style="list-style-type: none"> <li>Open valves</li> <li>Change inaccurate part</li> <li>Start pump rotor</li> <li>Change inaccurate part</li> </ul>
<b>Great oscillations of working pressure</b>	Too fast and too big changes of working pressure	<ul style="list-style-type: none"> <li>One valve off</li> <li>Expansion dish pressure inadequate</li> <li>Inaccurate dish</li> </ul>	<ul style="list-style-type: none"> <li>Open the valve</li> <li>Check pressure in expansion dish and if needed set dish pressure adequately</li> <li>Change inaccurate part</li> </ul>
<b>The boiler does not switch on the heaters by displaying a fault in the display</b>	It is possible to set the operating temperature and power, but the heaters do not turn on but an error code appears	<ul style="list-style-type: none"> <li>Circulation pump off</li> <li>Defective circulation pump</li> <li>System pressure is not within the permissible range</li> <li>The temperature is not within the permissible range</li> <li>Some of the sensors are not connected or incorrect</li> </ul>	<ul style="list-style-type: none"> <li>Switch on the pump and check for proper operation</li> <li>Replace defective part</li> <li>Adjust the pressure to the required value</li> <li>Set the temperature to the required value</li> <li>Replace faulty part according to fault code (section 7.3.5).</li> </ul>

Table 6: Troubles and troubleshooting

## 11. Product data sheet (in accordance with EU regulation no. 811/2013)

1.	Manufacturer		MIKOTERM DOO
2.	Brand name		Adveco Standard
3.	Models	<b>I</b>	Adveco Standard 50kW
		<b>II</b>	Adveco Standard 60kW
		<b>III</b>	Adveco Standard 70kW
		<b>IV</b>	Adveco Standard 80kW
		<b>V</b>	Adveco Standard 90kW
		<b>VI</b>	Adveco Standard 100kW
		<b>VII</b>	Adveco Standard 120kW
		<b>VIII</b>	Adveco Standard 140kW
		<b>IX</b>	Adveco Standard 160kW
		<b>X</b>	Adveco Standard 180kW
		<b>XI</b>	Adveco Standard 200kW
		<b>XII</b>	Adveco Standard 240kW

				<b>I</b>	<b>II</b>	<b>III</b>	<b>IV</b>	<b>V</b>	<b>VI</b>	<b>VII</b>	<b>VIII</b>	<b>IX</b>	<b>X</b>	<b>XI</b>	<b>XII</b>
4.	Room heating: Seasonal energy- efficiency class			D	D	D	D	D	D	D	D	D	D	D	D
5.	Room heating: Nominal heat output(*8) (*11)	$P_{rated}$	kW	50	60	70	80	90	100	120	140	160	180	200	240
6.	Room heating: Seasonal energy efficiency(*8)	$\eta_s$	%	37,87	37,95	38	38,02	38,04	38,07	38,09	38,12	38,20	38,24	38,27	38,30
7.	Annual energy consumption(*8)	$Q_{HE}$	kWh	59425	71310	83195	95080	106965	118550	142620	166390	190160	213930	237700	285240
8.	Sound power level, indoor	$L_{WA}$ indoor	dB(A)	50	52	54	55	56	58	60	62	64	66	68	70
9.	 <p>All specific precautions for assembly, installation and maintenance are described in the operating and installation instructions. Read and follow the operating and installation instructions.</p>														
10.	 <p>All of the data that is included in the product information was determined by applying the specifications of the relevant European directives. Differences to product information listed elsewhere may result in different test conditions. Only the data that is contained in this product information is applicable and valid.</p>														

(\*8) For average climatic conditions

(\*11) For boilers and combination boilers with a heat pump, the nominal heat output "Prated" is the same as the design load in heating mode "Pdesignh", and the nominal heat output for an auxiliary boiler "Psup" is the same as the additional heating output "sup(Tj)"

---

## Contact Details

The Adveco Electric Boiler range, this manual, and all information contained within, are supplied by Adveco Ltd.

### **UK**

Adveco Ltd.  
Unit 7&8 Armstrong Mall,  
Southwood Business Park,  
Farnborough,  
Hampshire,  
GU14 0NR

T: 01252 551 540  
[enquiries@adveco.co](mailto:enquiries@adveco.co)  
[www.adveco.co](http://www.adveco.co)

---

### **Adveco Sales Department**

T: 01252 551 540 Option 1  
E: [Sales@adveco.co](mailto:Sales@adveco.co)

### **Adveco Spares Department**

T: 01252 551 540 Option 3  
E: [Spares@adveco.co](mailto:Spares@adveco.co)

### **Adveco Technical Support Department**

T: 01252 551 540 Option 4  
E: [Technical@adveco.co](mailto:Technical@adveco.co)

### **Adveco Design Department**

T: 01252 551 540 Option 5  
E: [Technical@adveco.co](mailto:Technical@adveco.co)

### **Adveco Service & Commissioning Department**

T: 01252 551 540 Option 6  
E: [Service@adveco.co](mailto:Service@adveco.co)

---

