

## ADVECO FUSION

Packaged Electric Water Heating

[www.adveco.co](http://www.adveco.co)



# ADVECO FUSION

FUSION-E | FUSION-Eplus | FUSION-T | FUSION-Tplus

The Adveco FUSION range is a low carbon, all-electric packaged hot water system combining a tough stainless steel cylinder and a choice of 9 to 24 kW electric boiler. Easy to install and maintain, FUSION water heaters are presized for commercial projects.

With the addition of a 6 or 10 kW air source heat pump (ASHP) to supply preheat, projects can integrate greater sustainability to reduce carbon emissions and control operational costs. Adveco's advanced controls balance the energy input from the ASHP and electric boiler to maximise system efficiency.

For projects requiring additional resilience FUSION provides the option to integrate an electric immersion with automatic control and alerts for assured business continuity.



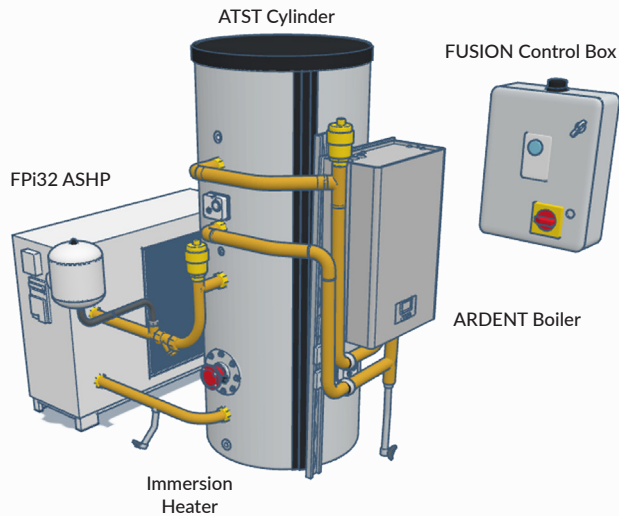

FUSION-Tplus System

The next generation FUSION range is a modern, future-proof system that embraces electric water heating and the option to incorporate an ASHP to lower carbon emissions in line with government calls for net zero.

As an all-electric system, it uses familiar technology that is relatively simple and quick to install, cost-effective, reduces carbon emissions and removes dangerous NOx emissions for improved indoor air quality (IAQ) for enhanced occupant comfort.

With an increased heating capacity over first generation Adveco FUSION systems, the next generation of FUSION offers greater versatility for meeting domestic hot water (DHW) demands across a range of properties used for commercial operations.

The packaged, pre-sized format enables flexibility to specify from a range of cylinders, primary electrical heating, air source heat pumps for preheat, immersions for back-up all supported by Adveco's bespoke controls to ensure optimal, efficient operation.

FUSION is the perfect response for building projects with small to medium basin and sink led hot water demands. Taller buildings with basement plant rooms. Businesses that depend on 24/7 hot water provision for continuity of service.

UP TO  
**56%**  
CARBON EMISSIONS SAVINGS

[www.adveco.co](http://www.adveco.co)

# ADVECO FUSION

## FUSION-E | FUSION-Eplus Electric Water Heaters

### FEATURES

#### FUSION-E

- High-quality ATSI single coil stainless steel vessel with mounting points & brackets
- Available with 300 to 750 litre capacities
- Cylinder pressure 10 bar as standard
- 9, 12 or 24 kW electric boiler
- Pre-built pipework (left or right)
- Thermostat and overheat thermostat
- Compact space-saving form factor
- 15 pre-sized variants from 9 to 24 kW

#### FUSION-Eplus

- 6 kW electric immersion
- FUSION Control Box
- Automatic backup with remote alerts
- 15 pre-sized variants 9 to 24 kW

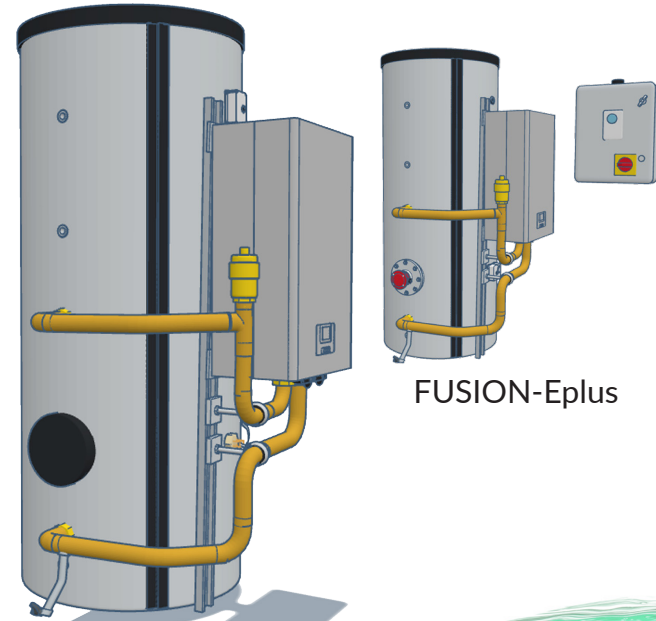

FUSION-E

FUSION-Eplus



# ADVECO FUSION

## FUSION-T | FUSION-Tplus

### FEATURES

#### FUSION-T

- High-quality ATST twin coil stainless steel vessel with mounting points & brackets
- Available with 300 - 750 litre capacities
- Cylinder pressure 10 bar as standard
- 9, 12 or 24 kW ARDENT electric boiler
- 6 or 12 kW FPi32 air source heat pump
- Pre-built pipework (left or right)
- FUSION Control Box
- Compact space-saving form factor
- 25 pre-sized variants from 14 to 33 kW

#### FUSION-Tplus

- 6 kW electric immersion
- Automatic backup and remote alerts
- 25 pre-sized variants from 14 to 33 kW

FUSION-T

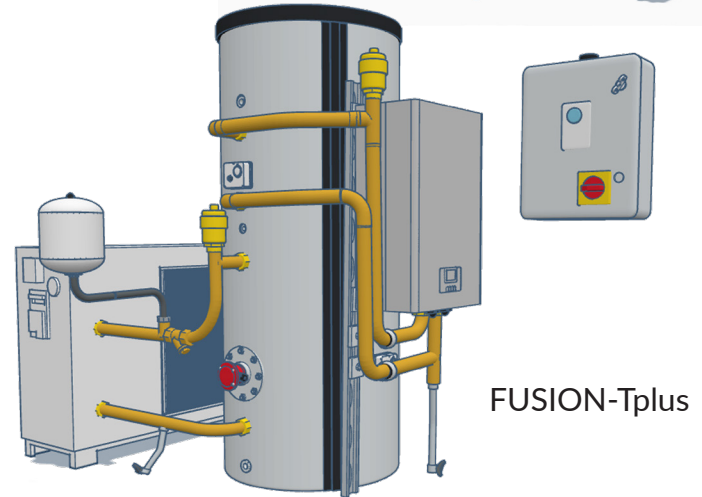
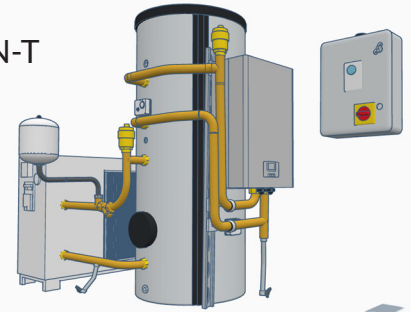

FUSION-Tplus

[www.adveco.co](http://www.adveco.co)

# ARDENT Premium Electric Boiler

Designed to serve an indirect water heater or heating system, multiple electric heating elements immersed into ARDENT's integrated water storage tank provide a rapid and reliable source of thermal energy for heat outputs from 9 to 24 kW

When integrated with a heat pump in FUSION-T and -Tplus systems, the ARDENT boiler provides a high-temperature energy source to top up pre-heated water from the ASHP, especially during colder months.

As part of FUSION's indirect hot water system, ARDENT helps eliminate scale build-up common on direct electrical immersion heaters in harder water areas.

The Adveco ARDENT Premium 9, 12 & 24 kW models feature two or three heating elements with six or nine circuits with a front-mounted controller with LCD display.

Each boiler includes an integrated expansion vessel, relief valve, and circulation pump. Additional controls include 3-port valve and fault output. All models boast a protective IP40-rated outer shell.

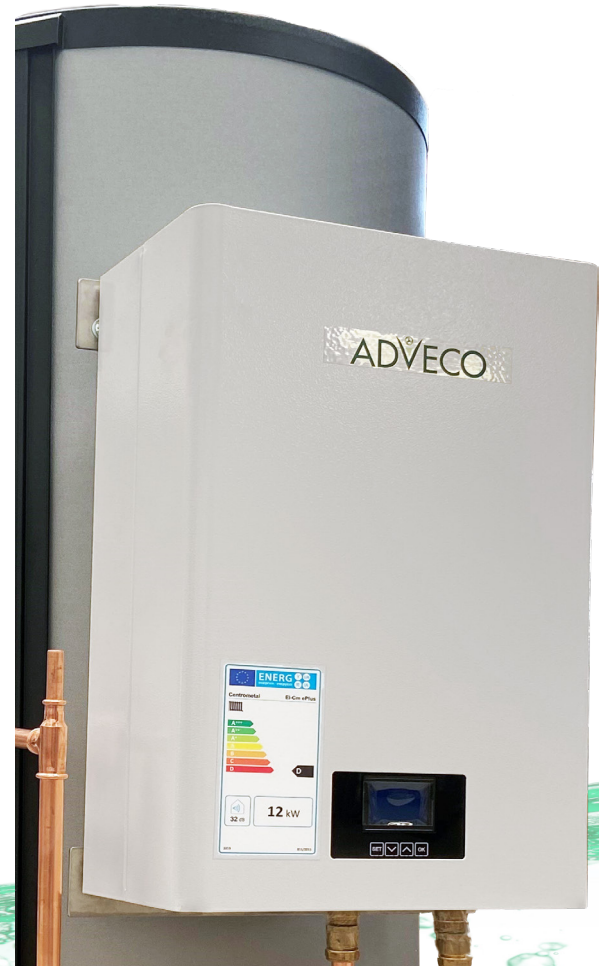

## Features

- Electric-only operation avoids reliance on gas energy supplies
- Multiple heating elements per unit provide built in redundancy
- Stepped element control to reduce start-up current and wear on heating elements
- Integrated overheat safety protection
- Simple integration into FUSION system
- Can help eliminate damaging limescale build-up in hard water areas
- Compact form factor that hangs on the hot water cylinder with bespoke brackets
- Silent operation

## Eliminating Scale

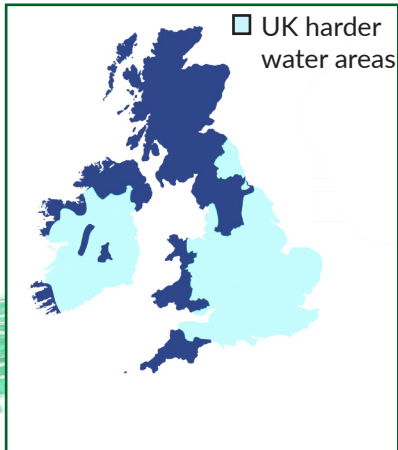

ARDENT utilises immersion heaters located in a small tank heat exchanger within the boiler housing. This electric boiler supplies a sealed 'primary' loop to an indirect coil in the FUSION cylinder.

The electric boiler heats the same water continuously so there is only a finite amount of scale in the system which will not damage the elements. The heat exchanger in the cylinder is a large coil operating at relatively low temperatures. Extensive experience with indirect coil use in the UK has shown that scale is not a significant problem in these systems.

The multiple immersions within the ARDENT tank also provide immediate resilience should one potentially fail.

[www.adveco.co](http://www.adveco.co)

# FPI32 Air Source Heat Pump

Adveco FUSION-T is built around the stylish FPI32 6 or 12 kW inverter-driven R-32 air source heat (ASHP). Conceived to consistently supply low carbon hot water for commercial applications with higher thermal requirements, the compact monobloc FPI32 is the environmentally-friendly choice.

Transferring heat from the air to a building, the FPI32 can provide hot water up to 55°C throughout the year, even when ambient air temperatures drop as low as -25°C. As part of the FUSION-T hybrid water heater, hot water is preheated to a consistent 50°C, increasing system efficiency without compromising reliability or performance.

This reduces energy demands, operating costs and provides 53% carbon emission savings when compared to an equivalent direct electric-only system.

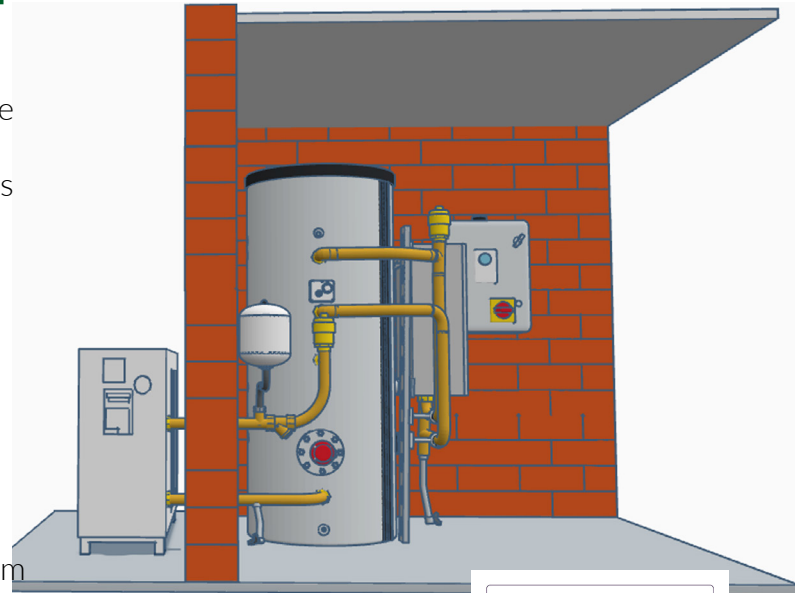

## Features

- Specified as an integral element of the Fusion system, FPi32 ASHPs rapidly achieve and then sustain the desired temperature to preheat water for commercial applications
- Able to achieve above-average COP, the highly efficient FPi32 heat pumps are one of the lowest cost ways to effectively provide hot water to a building
- Only a very small amount of electricity is required to operate the compressor
- Reduced environmental impact with improved efficiency from R-32 refrigerant
- Quick to install with minimal space requirements and virtually maintenance-free



# ATSI & ATST Stainless Steel Cylinders

The FUSION-E and -T ranges make excellent use of the ATSI and ATST water heating vessels as a system calorifier. Compact and robust, these vessels are the perfect choice for projects with hot water demands based around sinks and basins. Multiple storey buildings are no issue for the tanks' high-pressure (10 bar) specification.

The entire FUSION range is available in a choice of capacities including 300, 400, 500, 580 and 750 litres.

The FUSION-E and -Eplus ranges offers a choice of 300 to 750-litre capacity ATSIs. These vessels feature a single internal high-capacity fixed coil indirectly heated by the ARDENT electric boiler. ATSI supports the addition of a direct-electric immersion for the FUSION-Eplus models.

The FUSION-T and -Tplus ranges offers a choice of 300 to 750-litre capacity ATSTs. These vessels feature twin internal fixed coils. The lower indirectly heated by the FPi32 ASHP, and the upper by the ARDENT electric boiler. The ATST also supports the addition of a direct-electric immersion for the FUSION-Tplus models.

For those wishing to futureproof a specification the FUSION-E systems can also be supplied with a twin-coil ATST cylinder as an alternative to the ATSI. Prebuilt pipework provides connection for the electric boiler to the lower coil in this case. The addition of a heat pump later can therefore be supported with a new pipework kit and controls upgrading the system to a FUSION-T specification.

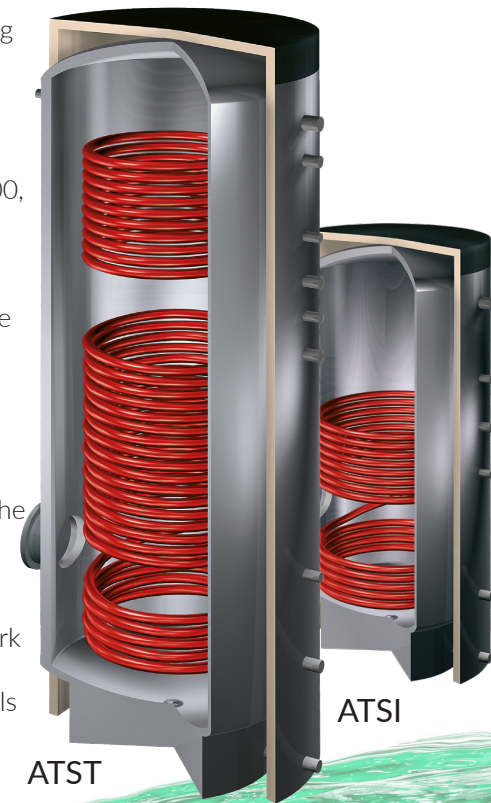



## Features

- Available from 300 to 750 litre capacities
- Produced from high-quality 316Ti and 316L stainless steel
- 100 mm removable insulation for improved energy efficiency
- Suitable for vented or unvented installation
- 10 bar / 95°C max. working pressure/temp (tank)
- 25 bar / 200°C max. working pressure/temp (coil/s)
- Integrated mounting points on left and right
- Front facing connections for ease of installation and maintenance

## The Resilient Choice

Fusing either an ATSI or ATST stainless steel vessel with the ARDENT electric boiler an optional FPi32 ASHP and electric immersions makes FUSION one of the most resilient options for commercial water heating projects on the market.

FUSION is less susceptible to corrosion experienced in naturally soft water conditions. The high-quality 316Ti and 316L stainless steel alloy create a protective oxide barrier on the waterside that naturally helps prevent corrosion, even when temperatures increase. In hard water areas, scale build-up is highly curtailed by the use of the ARDENT boiler for primary indirect heating. Able to withstand higher temperature water (in excess of 80°C) FUSION lends itself to a wide mix of commercial applications making it the ideal choice for projects in the UK, no matter the water quality.

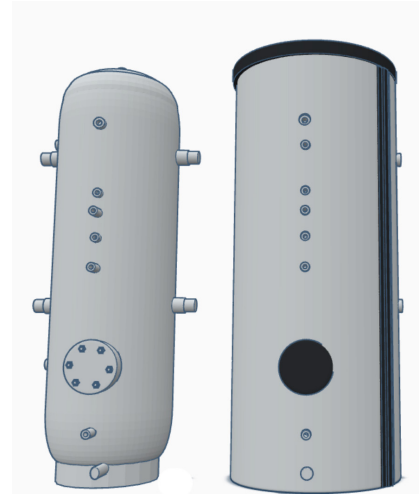

# FUSION Control

The design of efficient hybrid systems depends on harmoniously balancing the different elements to ensure that they do not work against each other. If the coil and immersion are situated closely together they become impossible to accurately control and system efficiency would be lost. FUSION, through a mix of innovative design and dedicated controls ensures the ASHP preheat and immersion work seamlessly to deliver the highest operational efficiencies.

FUSION controls incorporate a set of submetering options to monitor the heat pump, immersion and water flow. This provides clear sight of energy and water usage to better manage day-to-day operations. Timer controls and remote control via BMS ensure FUSION is only operating when required, maximising energy demands.

For FUSION-Tplus and FUSION-Eplus variants additional controls manage emergency switch over to electric immersion heating. Building managers will receive a text alert to warn that the system has switched over to back-up mode.



## Features

- On/Off functionality via time clock or BMS
- Fault output
- Thermal disinfection for Legionella prevention
- Day & weekly timer
- Submetering
- Rugged IP55 case
- GSM messaging (FUSIONplus models)

FUSION controls and submetering smartly balance pre-heat provided by the FPi32 ASHP with the direct electric top-up from the ARDENT electric boiler to optimise efficiencies, reducing energy demands and delivering considerable carbon emission reduction.

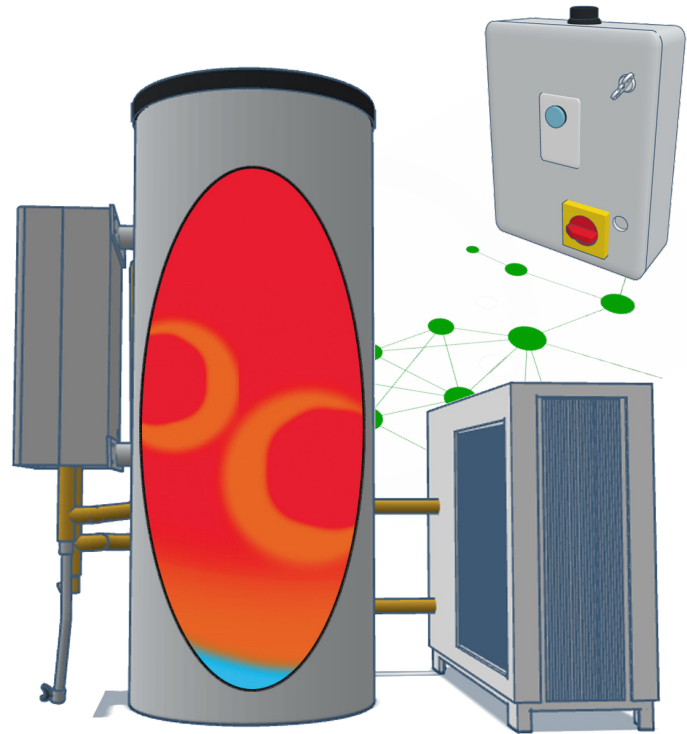

# FUSION-E Specifications

Model	Tank	ASHP Model	ARDENT Boiler Model	Backup Immersion	ASHP Rating (kW)	Boiler Rating (kW)	Continuous Flow Rate (L/h)	30 Minute Peak (L)	60 Minute Peak (L)	120 Minute Peak (L)	Emissions savings vs. direct electric	Emissions savings vs. gas	Nominal power output (kW)
FE 300-9	ATSI 300	n/a	P9	n/a	n/a	9	154.3	181.2	258.3	412.6	0.00%	38.50%	9
FE 300-12	ATSI 300	n/a	P12	n/a	n/a	12	205.7	206.9	309.8	515.5	0.00%	38.50%	12
FE 300-24	ATSI 300	n/a	P24	n/a	n/a	24.3	416.6	312.3	520.6	937.2	0.00%	38.50%	24
FE 400-9	ATSI 400	n/a	P9	n/a	n/a	9	154.3	222.6	299.8	454.1	0.00%	38.50%	9
FE 400-12	ATSI 400	n/a	P12	n/a	n/a	12	205.7	248.3	351.2	556.9	0.00%	38.50%	12
FE 400-24	ATSI 400	n/a	P24	n/a	n/a	24.3	416.6	353.8	562.1	978.6	0.00%	38.50%	24
FE 500-9	ATSI 500	n/a	P9	n/a	n/a	9	154.3	250.9	328	482.3	0.00%	38.50%	9
FE 500-12	ATSI 500	n/a	P12	n/a	n/a	12	205.7	276.6	379.5	585.2	0.00%	38.50%	12
FE 500-24	ATSI 500	n/a	P24	n/a	n/a	24.3	416.6	382	590.3	1006.9	0.00%	38.50%	24
FE 580-9	ATSI 580	n/a	P9	n/a	n/a	9	154.3	257.5	334.6	488.9	0.00%	38.50%	9
FE 580-12	ATSI 580	n/a	P12	n/a	n/a	12	205.7	283.2	386	591.8	0.00%	38.50%	12
FE 580-24	ATSI 580	n/a	P24	n/a	n/a	24.3	416.6	388.6	596.9	1013.5	0.00%	38.50%	24
FE 750-9	ATSI 750	n/a	P9	n/a	n/a	9	154.3	329	406.1	560.4	0.00%	38.50%	9
FE 750-12	ATSI 750	n/a	P12	n/a	n/a	12	205.7	354.7	457.5	663.3	0.00%	38.50%	12
FE 750-24	ATSI 750	n/a	P24	n/a	n/a	24.3	416.6	460.1	668.4	1085	0.00%	38.50%	24

\*Carbon emission savings calculated versus equivalent-sized and specified systems using only gas or direct electric energy without ASHP preheat

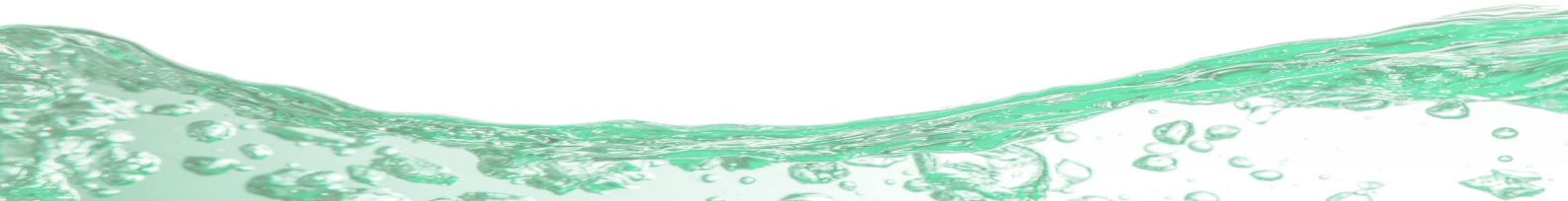

# FUSION-Eplus Specifications

Model	Tank	ASHP Model	ARDENT Boiler Model	Backup Immersion	ASHP Rating (kW)	Boiler Rating (kW)	Continuous Flow Rate (L/h)	30 Minute Peak (L)	60 Minute Peak (L)	120 Minute Peak (L)	Emissions savings vs. direct electric	Emissions savings vs. gas	Nominal power output (kW)
FEplus 300-9	ATSI 300	n/a	P9	6kW	n/a	9	154.3	181.2	258.3	412.6	0.00%	38.50%	9
FEplus 300-12	ATSI 300	n/a	P12	6kW	n/a	12	205.7	206.9	309.8	515.5	0.00%	38.50%	12
FEplus 300-24	ATSI 300	n/a	P24	6kW	n/a	24.3	416.6	312.3	520.6	937.2	0.00%	38.50%	24
FEplus 400-9	ATSI 400	n/a	P9	6kW	n/a	9	154.3	222.6	299.8	454.1	0.00%	38.50%	9
FEplus 400-12	ATSI 400	n/a	P12	6kW	n/a	12	205.7	248.3	351.2	556.9	0.00%	38.50%	12
FEplus 400-24	ATSI 400	n/a	P24	6kW	n/a	24.3	416.6	353.8	562.1	978.6	0.00%	38.50%	24
FEplus 500-9	ATSI 500	n/a	P9	6kW	n/a	9	154.3	250.9	328	482.3	0.00%	38.50%	9
FEplus 500-12	ATSI 500	n/a	P12	6kW	n/a	12	205.7	276.6	379.5	585.2	0.00%	38.50%	12
FEplus 500-24	ATSI 500	n/a	P24	6kW	n/a	24.3	416.6	382	590.3	1006.9	0.00%	38.50%	24
FEplus 580-9	ATSI 580	n/a	P9	6kW	n/a	9	154.3	257.5	334.6	488.9	0.00%	38.50%	9
FE plus 580-12	ATSI 580	n/a	P12	6kW	n/a	12	205.7	283.2	386	591.8	0.00%	38.50%	12
FEplus 580-24	ATSI 580	n/a	P24	6kW	n/a	24.3	416.6	388.6	596.9	1013.5	0.00%	38.50%	24
FEplus 750-9	ATSI 750	n/a	P9	6kW	n/a	9	154.3	329	406.1	560.4	0.00%	38.50%	9
FEplus 750-12	ATSI 750	n/a	P12	6kW	n/a	12	205.7	354.7	457.5	663.3	0.00%	38.50%	12
FEplus 750-24	ATSI 750	n/a	P24	6kW	n/a	24.3	416.6	460.1	668.4	1085	0.00%	38.50%	24



# FUSION-T Specifications

Model	Tank	ASHP Model	ARDENT Boiler Model	Backup Immersion	ASHP Rating (50/55 @ 2°C amb) (kW)	Calculated Boiler Output (kW)	Continuous Flow Rate (L/h)	30 Minute Peak (L)	60 Minute Peak (L)	120 Minute Peak (L)	Emissions savings vs. direct electric	Emissions savings vs. gas	Nominal combined power output (kW)
FT 300-14	ATST 300	FPI32-6	P9	n/a	4.72	9	235.2	221.7	339.3	574.5	24.30%	53.40%	14
FT 300-17	ATST 300	FPI32-6	P12	n/a	4.72	12	286.6	247.4	390.7	677.3	20.00%	50.80%	17
FT 300-21	ATST 300	FPI32-12	P12	n/a	8.62	12	353.5	280.8	457.5	811	29.20%	56.40%	21
FT 300-22	ATST 300	FPI32-6	P24	n/a	4.72	16.81	369.1	288.6	473.2	842.3	15.50%	48.00%	22
FT 300-24	ATST 300	FPI32-12	P24	n/a	8.62	15.41	411.9	310	516	927.9	25.00%	53.90%	24
FT 400-14	ATST 400	FPI32-6	P9	n/a	4.72	9	235.2	263.1	380.7	615.9	24.30%	53.40%	14
FT 400-17	ATST 400	FPI32-6	P12	n/a	4.72	12	286.6	288.8	432.1	718.7	20.00%	50.80%	17
FT 400-21	ATST 400	FPI32-12	P12	n/a	8.62	12	353.5	322.2	499	852.5	29.20%	56.40%	21
FT 400-24	ATST 400	FPI32-6	P24	n/a	4.72	19.12	408.7	349.9	554.2	962.9	14.00%	47.10%	24
FT 400-26	ATST 400	FPI32-12	P24	n/a	8.62	17.67	450.6	370.8	596.1	1046.8	22.90%	52.60%	26
FT 500-14	ATST 500	FPI32-6	P9	n/a	4.72	9	235.2	291.4	409	644.2	24.30%	53.40%	14
FT 500-17	ATST 500	FPI32-6	P12	n/a	4.72	12	286.6	317.1	460.4	747	20.00%	50.80%	17
FT 500-21	ATST 500	FPI32-12	P12	n/a	8.62	12	353.5	350.5	527.2	880.7	29.20%	56.40%	21
FT 500-24	ATST 500	FPI32-6	P24	n/a	4.72	19.12	408.7	378.1	582.5	991.2	14.00%	47.10%	24
FT 500-26	ATST 500	FPI32-12	P24	n/a	8.62	17.67	450.6	399.1	624.4	1075	22.90%	52.60%	26
FT 580-14	ATST 580	FPI32-6	P9	n/a	4.72	9	235.2	297.9	415.5	650.7	24.30%	53.40%	14
FT 580-17	ATST 580	FPI32-6	P12	n/a	4.72	12	286.6	323.6	467	753.6	20.00%	50.80%	17
FT 580-21	ATST 580	FPI32-12	P12	n/a	8.62	12	353.5	357.1	533.8	887.3	29.20%	56.40%	21
FT 580-24	ATST 580	FPI32-6	P24	n/a	4.72	19.12	408.7	384.7	589.1	997.8	14.00%	47.10%	24
FT 580-26	ATST 580	FPI32-12	P24	n/a	8.62	17.67	450.6	405.7	631	1081.6	22.90%	52.60%	26
FT 750-14	ATST 750	FPI32-6	P9	n/a	4.72	9	235.2	369.4	487	722.2	24.30%	53.40%	14
FT 750-17	ATST 750	FPI32-6	P12	n/a	4.72	12	286.6	395.1	538.5	825.1	20.00%	50.80%	17
FT 750-21	ATST 750	FPI32-12	P12	n/a	8.62	12	353.5	428.6	605.3	958.8	29.20%	56.40%	21
FT 750-29	ATST 750	FPI32-6	P24	n/a	4.72	24.3	497.5	500.6	749.3	1246.8	11.50%	45.50%	29
FT 750-33	ATST 750	FPI32-12	P24	n/a	8.62	24.3	564.3	534	816.2	1380.5	18.30%	49.70%	33

\*Carbon emission savings calculated versus equivalent-sized and specified systems using only gas or direct electric energy without ASHP preheat



# FUSION-Tplus Specifications

Model	Tank	ASHP Model	ARDENT Boiler Model	Backup Immersion	ASHP Rating (50/55 @ 2°C amb) (kW)	Calculated Boiler Output (kW)	Continuous Flow Rate (L/h)	30 Minute Peak (L)	60 Minute Peak (L)	120 Minute Peak (L)	Emissions savings vs. direct electric	Emissions savings vs. gas	Nominal combined power output (kW)
FTplus 300-14	ATST 300	FPI32-6	P9	6kW	4.72	9	235.2	221.7	339.3	574.5	24.30%	53.40%	14
FTplus 300-17	ATST 300	FPI32-6	P12	6kW	4.72	12	286.6	247.4	390.7	677.3	20.00%	50.80%	17
FTplus 300-21	ATST 300	FPI32-12	P12	6kW	8.62	12	353.5	280.8	457.5	811	29.20%	56.40%	21
FTplus 300-22	ATST 300	FPI32-6	P24	6kW	4.72	16.81	369.1	288.6	473.2	842.3	15.50%	48.00%	22
FTplus 300-24	ATST 300	FPI32-12	P24	6kW	8.62	15.41	411.9	310	516	927.9	25.00%	53.90%	24
FTplus 400-14	ATST 400	FPI32-6	P9	6kW	4.72	9	235.2	263.1	380.7	615.9	24.30%	53.40%	14
FTplus 400-17	ATST 400	FPI32-6	P12	6kW	4.72	12	286.6	288.8	432.1	718.7	20.00%	50.80%	17
FTplus 400-21	ATST 400	FPI32-12	P12	6kW	8.62	12	353.5	322.2	499	852.5	29.20%	56.40%	21
FTplus 400-24	ATST 400	FPI32-6	P24	6kW	4.72	19.12	408.7	349.9	554.2	962.9	14.00%	47.10%	24
FTplus 400-26	ATST 400	FPI32-12	P24	6kW	8.62	17.67	450.6	370.8	596.1	1046.8	22.90%	52.60%	26
FTplus 500-14	ATST 500	FPI32-6	P9	6kW	4.72	9	235.2	291.4	409	644.2	24.30%	53.40%	14
FTplus 500-17	ATST 500	FPI32-6	P12	6kW	4.72	12	286.6	317.1	460.4	747	20.00%	50.80%	17
FTplus 500-21	ATST 500	FPI32-12	P12	6kW	8.62	12	353.5	350.5	527.2	880.7	29.20%	56.40%	21
FTplus 500-24	ATST 500	FPI32-6	P24	6kW	4.72	19.12	408.7	378.1	582.5	991.2	14.00%	47.10%	24
FTplus 500-26	ATST 500	FPI32-12	P24	6kW	8.62	17.67	450.6	399.1	624.4	1075	22.90%	52.60%	26
FTplus 580-14	ATST 580	FPI32-6	P9	6kW	4.72	9	235.2	297.9	415.5	650.7	24.30%	53.40%	14
FTplus 580-17	ATST 580	FPI32-6	P12	6kW	4.72	12	286.6	323.6	467	753.6	20.00%	50.80%	17
FTplus 580-21	ATST 580	FPI32-12	P12	6kW	8.62	12	353.5	357.1	533.8	887.3	29.20%	56.40%	21
FTplus 580-24	ATST 580	FPI32-6	P24	6kW	4.72	19.12	408.7	384.7	589.1	997.8	14.00%	47.10%	24
FTplus 580-26	ATST 580	FPI32-12	P24	6kW	8.62	17.67	450.6	405.7	631	1081.6	22.90%	52.60%	26
FTplus 750-14	ATST 750	FPI32-6	P9	6kW	4.72	9	235.2	369.4	487	722.2	24.30%	53.40%	14
FTplus 750-17	ATST 750	FPI32-6	P12	6kW	4.72	12	286.6	395.1	538.5	825.1	20.00%	50.80%	17
FTplus 750-21	ATST 750	FPI32-12	P12	6kW	8.62	12	353.5	428.6	605.3	958.8	29.20%	56.40%	21
FTplus 750-29	ATST 750	FPI32-6	P24	6kW	4.72	24.3	497.5	500.6	749.3	1246.8	11.50%	45.50%	29
FTplus 750-33	ATST 750	FPI32-12	P24	6kW	8.62	24.3	564.3	534	816.2	1380.5	18.30%	49.70%	33

# FUSION Specifications - ARDENT Electric Boiler

Ardent Premium Technical Specifications	P9	P12	P24
Heat output range (kW)	9.0	12.0	24.3
Element configuration	6 × 1.5	6 × 2.0	9 × 2.7
Power supply (V <sub>AC</sub> / Phases / Hz)	240 / 1 phase / 50		400 / 3 phase / 50
Fuse requirement (A)	20	25	40
Inlet and outlet connections (inch)	G 3/4"	G 3/4"	G 3/4"
Boiler water content (l)	12.5	12.5	12.5
Expansion vessel water content (l)	7.0	7.0	7.0
Maximum operating temperature	80	80	80
Operating pressure range (bar)	0.8 – 2.2	0.8 – 2.2	0.8 – 2.2
Energy efficiency class	D	D	D
Housing protection	IP40	IP40	IP40
Dimensions H × W × D (mm)	700 × 430 × 230	700 × 430 × 230	700 × 430 × 230
Dry mass (kg)	25	25	25

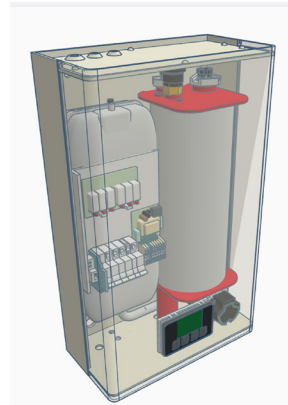

ARDENT P9 | P12 | P24

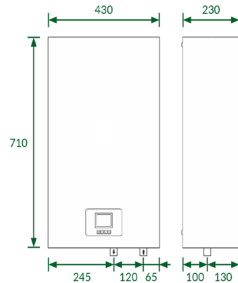

## Controls Box Specification

## Units

Dimensions HxWxD	mm	500x400x210
------------------	----	-------------



ARDENT P9 | P12 | P24

# FUSION Specifications - FPi32 ASHP

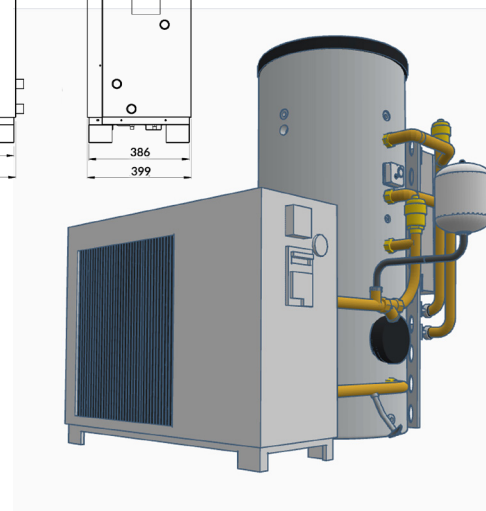
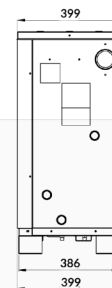
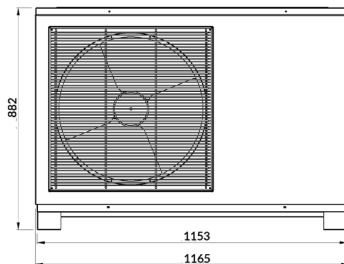
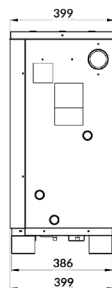
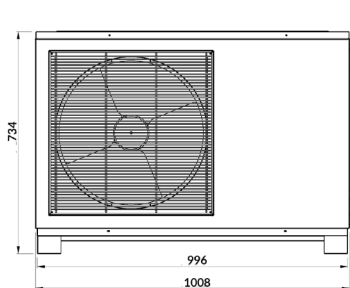

## FPi32-6

## FPi32-12

ASHP Specifications	Units	FPi32-6	FPi32-12
Dimensions HxWxD	mm	734x1008x399	882x1165x399
Run current	A	8	15
Refrigerant (R32)	kg	0.9	1.8
Heating capacity min./max.	kW	3.50/7.45	5.50/11.67
Heating Power Input min./max.	kW	7.58/14.10	11.07/26.83
Seasonal COP (SCOP)		4.74	4.71
Rated power water pump	W		87
Noise level (outdoor)	dB(A)		52

Heating condition: Water in/out temperature 30°C/35°C. Ambient temperature DB/WB 7/6°C.

# ATSI Hot Water Cylinder

## ATSI Range Specifications

Description	300	400
Volume (l)	289	411
Energy efficiency class	B	B
Standing losses W	63	72
Coil surface area (m <sup>2</sup> )	1.4	1.7
Output capacity (80/60:10/60) (kW)	29.7	36.1
DHW flow rate (80/60:10/60) (l/h)	509.7	619.5
DHW Peak draw off capacity (l)	30 min. 444 60 min. 702 120 min. 1208	587 901 1516

## ATSI Range Dimensions

Description	300	400
Height including insulation (mm)	1740	1735
Outer diameter Including insulation (mm)	Ø700	Ø800
Inner diameter (mm)	Ø500	Ø600
Dry Mass (kg)	68	40

# ATST Hot Water Cylinder

## ATST Range Specifications

Description		300	400	500
Volume (l)		289	411	490
Energy efficiency class		B	B	B
Standing losses	W	71	76	83
Coil surface area (m <sup>2</sup> )	Lower coil Upper coil	1.4 0.8	1.7 0.9	1.7 0.9
Output capacity (kW) (80/60:10/60)	Lower coil Upper coil	29.7 17.0	36.1 19.1	36.1 19.1
Continuous DHW flow rate (80/60:10/60) (l/h)	Upper coil Combined coils	291.7 801.4	327.8 947.2	327.8 947.2
DHW Peak draw off capacity (l) Combined coils	30 min. 60 min. 120 min.	565 971 1767	723 1203 2144	787 1266 2208

## ATST Range Dimensions

Description	300	400	500
Height including insulation (mm)	1740	1735	1990
Outer diameter Including insulation (mm)	Ø700	Ø800	Ø800
Inner diameter (mm)	Ø500	Ø600	Ø600
Dry mass (kg)	76	94	105

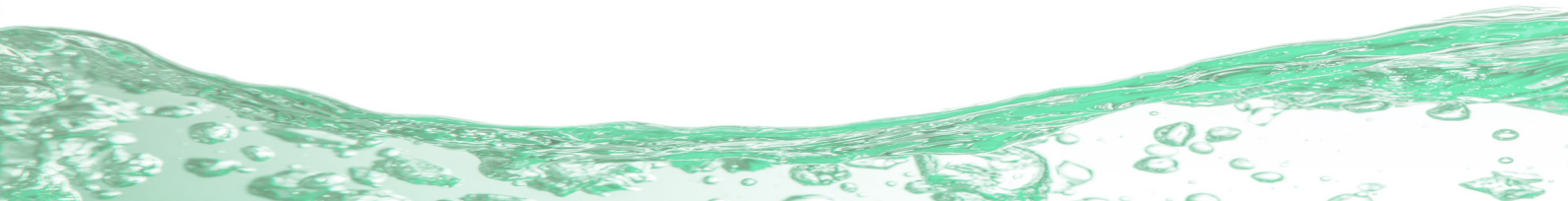

**Making Complex Commercial Hot Water Systems Easy**

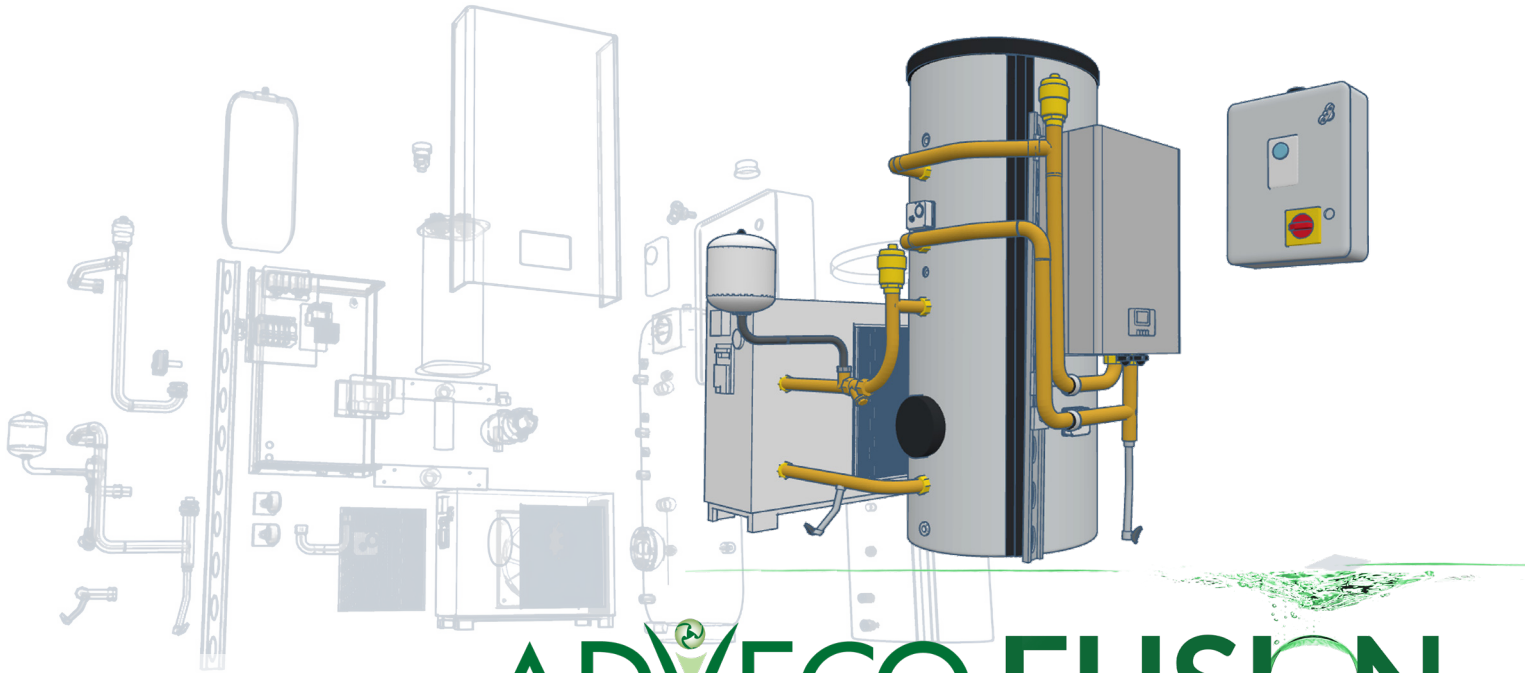

**ADVECO FUSION**

  
**ADVECO**  
HOT WATER SPECIALISTS



**FUSION**

T | 01252 551 540 E | [enquiries@adveco.co](mailto:enquiries@adveco.co)

Adveco Ltd. Unit 7 & 8 Armstrong Mall,  
Southwood Business Park, Farnborough, Hampshire  
GU14 0NR

ADVECO FUSION PACKAGED ELECTRIC WATER  
HEATER PRODUCT GUIDE SR60024.5

[www.adveco.co](http://www.adveco.co)

© Adveco Ltd. 2024 Company Reg : 09493966