

# Advenco Ardent S60, S80, S100

Indirect Electric Floor Standing Boilers from 60–100 kW



The Advenco Ardent range of floor standing electric boilers are designed to provide a high capacity and reliable solution to a building's hot water and central heating demands.

The Advenco Ardent electric boiler range features multiple electric heating elements immersed into an integrated water storage tank to provide a rapid and reliable source of thermal energy to serve a heating system or indirect water heater.

Available as a floor standing appliance with outputs from 60 to 100 kW, the Ardent features stepped element control to economically adjust the heating load when approaching set point temperature, and range rating to tailor the boiler power to suit the application.

All boilers feature an integral controller with LCD display and fault output in addition to an automatic air relief valve, safety valve, and temperature and pressure sensors all enclosed within a protective IP20-rated outer shell with rear flanged pipework connections. The Ardent range is ideal for integration with heat pump systems to provide a high temperature energy source in the coldest period of the year.

## FEATURES

- Indirect hot water system design eliminates scale build-up common on direct electrical immersion heaters.
- Multiple heating elements per unit provide inbuilt redundancy.
- Stepped element control to reduce start-up current and excessive wear on heating elements.
- Simple integration into existing systems.
- Modern electric-only operation avoids reliance on gas energy supplies.

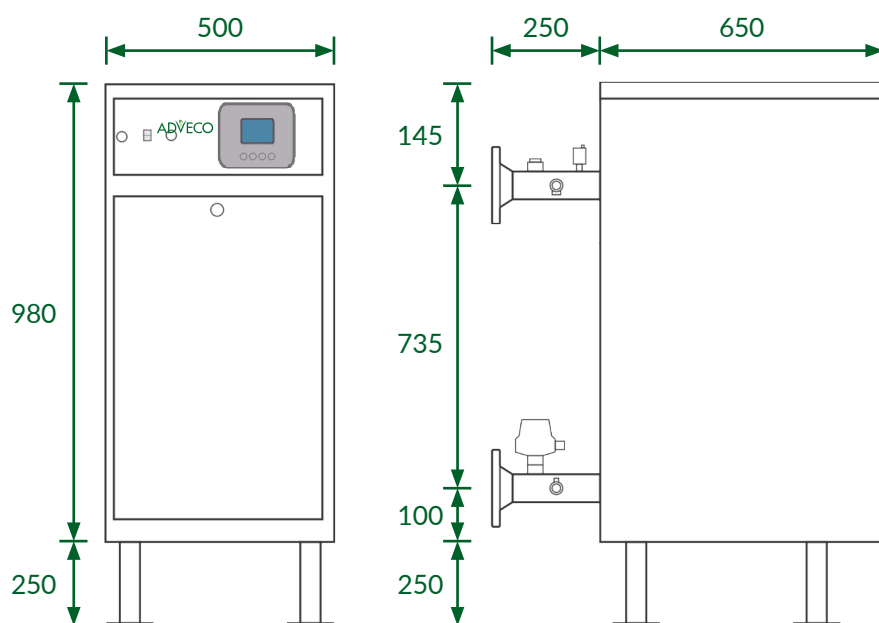

Standard: Technical Specifications	S60		S80		S100	
Power supply 3phase / 50Hz	400V	440V	400V	440V	400V	440V
Power output	60.0 kW	72.6 kW	80.0 kW	96.8 kW	100.0 kW	121.0 kW
Full load current at design resistance	87 A	96 A	116 A	128 A	145 A	160 A
Element configuration	6× 10.0 kW	6× 12.1 kW	8× 10.0 kW	8× 12.1 kW	10× 10.0 kW	10× 12.1 kW
Element rod resistance design/tolerance	15.9Ω ±10%		15.9Ω ±10%		15.9Ω ±10%	
Heating rod efficiency	100%		100%		100%	
Inlet and outlet connection (mm)	DN50 PN16		DN50 PN16		DN50 PN16	
Boiler water content (l)	95		95		95	
Operating temperature range (°C)	10-90		10-90		10-90	
Operating pressure range (bar)	0.4 – 2.6		0.4 – 3.6		0.4 – 3.6	
Dimensions H × W × D (mm)	1240 × 500 × 900		1240 × 500 × 900		1240 × 500 × 900	
Empty weight (kg)	92		106		120	