

Packaged Hot Water System Specification:

FTWplus400-22: Twin Coil Tank with Electric Boiler + ASHP

1. System Description

The system will feature a 400-litre stainless steel hot water tank fitted with two heating coils served by renewable and electric heat sources to provide a reliable and low-carbon electric hot water system with high corrosion resistance and reduced maintenance demands, and will be supplied complete with quick-fit boiler pipework and tank mounts, all heating controls, backup heating capacity, and legionella prevention features.

The stainless steel tank will contain a 1.7m² low-level and a 0.9m² high-level heating coil in addition to a mid-level inspection port which will be fitted with an immersion heater to serve as a backup heat source. The stainless steel tank will provide exceptional corrosion resistance in all UK water conditions without reliance upon anodic protection, which will reduce the demands and costs of water-side maintenance.

An air source heat pump will connect to provide low grade renewable heat into the lower coil of the hot water tank, transferring energy into the lower half of the tank. The air source heat pump will be mounted externally and provide 9.50 kW of heat input at 7°C outdoor temperatures and 6.95 kW at -7°C outdoor temperatures. The air source heat pump will use low-GWP refrigerant to minimise the environmental impact of the installation while extracting ambient heat from the outdoor air to preheat the incoming cold mains water in the lower half of the tank to approximately 50°C.

An electric boiler will connect to the upper coil of the hot water tank to provide up to 12 kW of high-grade heat to bring the preheated water in the tank up to the desired use and storage temperature. The electric boiler will use a sealed primary loop to greatly reduce the common issues of element wear and limescale build-up in the hot water tank. The electric boiler will be mounted directly onto the side of the stainless steel tank using connection mounts and brackets supplied with the tank, and a prefabricated quick-fit pipework assembly will be supplied to connect the boiler to the tank heat exchanger.

Mains cold water will enter the base of the hot water tank and be first heated indirectly by the air source heat pump, and will then be topped up by the indirect electric boiler to reach storage temperature. The system will be supplied with a wall-mounted control panel to provide power and switching to the installation, ensuring seamless integration of all system components inclusive of time control and twice weekly thermal disinfection programme to periodically sterilise the entire tank as a method of automated legionella prevention.

The system includes fault and backup handling using a 6 kW direct electric immersion heater in the hot water tank, able to provide a reserve level of hot water to prevent the system from running cold. In the event of a primary appliance fault the control panel will automatically activate the backup heat source to ensure continuity of hot water supply and will send an automated fault notification to alert store management and chosen service providers of the system status.

The electrical supply to the system shall be 38A. This is sufficient to operate the ASHP and the electric boiler plus all controls and ancillaries. The ASHP draws up to 19A single phase, leaving an available load of 19A per phase for the 12 kW electric boiler and ancillary components. This will provide a total system heat input of 21 kW in warm weather and 18 kW in cold weather.

Advenco will supply the plant equipment to site and provide commissioning following the completion of works. The site must have a forklift on the day of delivery. Plant siting, electrical and plumbing installation works, including lagging, pressure testing, frost protection, flushing and cleaning, will be the responsibility of the installer.

Heat Pump Model	ADVS10W	Heat Pump Power	10 kW
Boiler Model	P12	Boiler Power	12 kW
Tank Model	ATST 400	Storage Volume	400 Litres
Backup Immersion Model	810119K	Backup Immersion Power	6 kW
Recovery Time	1 Hour	Indoor Clearance Footprint	1450 x 1600 mm L x W 2000mm H
Tank+Boiler Full Weight	550 kg	Heat Pump Airflow Clearance	2500 x 2000 x 1300 mm
Heat Pump Full Weight	132 kg	Tank+Boiler Arrangement	Right- or left- handed pipework
Amperage Supply to Control Panel (ASHP + Boiler)	38A/ph		

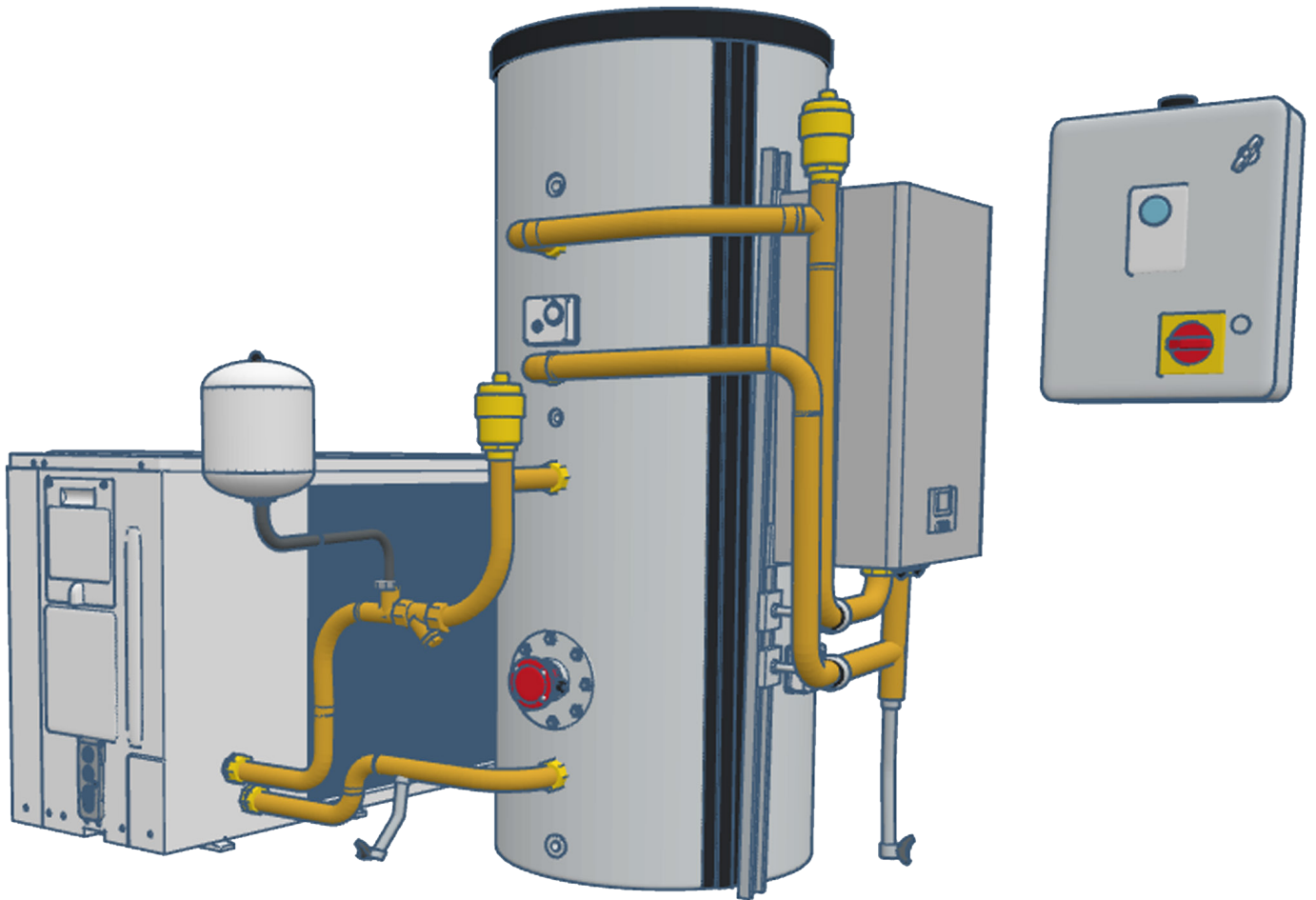

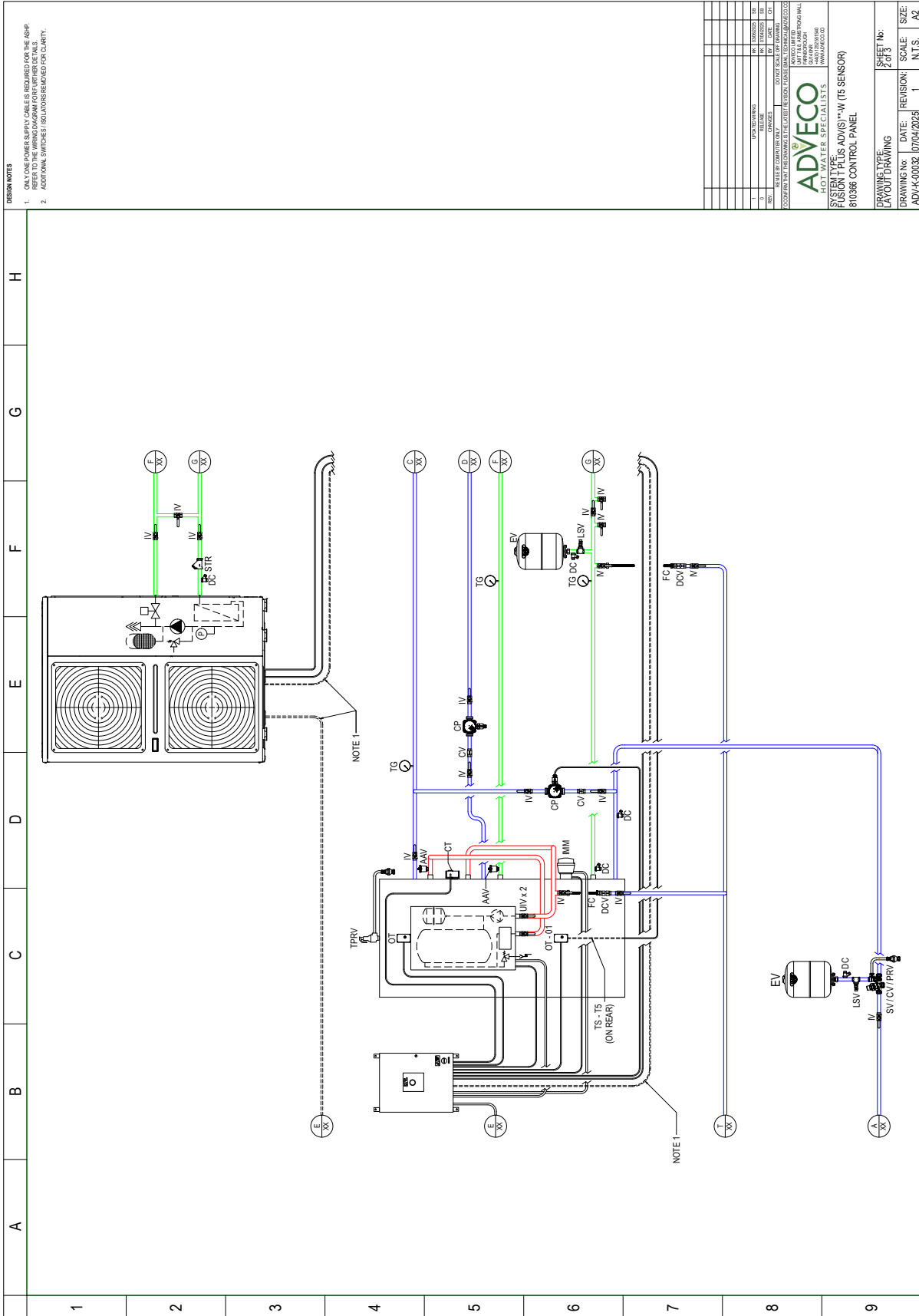

ADVS10W-16W / ADV16W-ADV30W

10-30kW Monobloc Air Source Heat Pump Range



The ADV air to water heat pump range includes models from 10 to 30 kW, bringing quality and efficiency to commercial heating and hot water systems.

Designed to extract heat from the ambient air using an environmentally friendly R32 refrigerant circuit, the air source heat pumps provide low carbon heat to a building and its hot water system through an integrated plate heat exchanger and pump, all contained within a modern and simple to install external monobloc unit.

Effective with ambient air temperatures as low as -25°C , the ASHP is capable of providing hot water at up to 60°C throughout the year while significantly reducing building emissions. The heat pump is ideal for installation as part of a hybrid hot water system, ensuring the highest degree of efficiency without compromise to overall performance or reliability.

FEATURES

- Single phase (10-16kW) and three phase (16-30kW) models available to suit every building
- Sleek and compact monobloc design
- High seasonal efficiency A+ to A+++ ErP Energy Rating
- Low GWP R32 refrigerant reduces environmental impact
- Low noise impact
- Maximum flow temperature 60°C
- Designed for UK climate conditions, maintaining a high efficiency down to -7°C
- Includes low voltage enable and fault signals, MODBUS support, built-in external pump and cascade controls, and a remote digital control interface as standard
- Low loss headers and external pumps available
- Available with warranty up to 5 years with scheduled annual servicing

ADVS10-16W: 10-16kW Single Phase ASHP

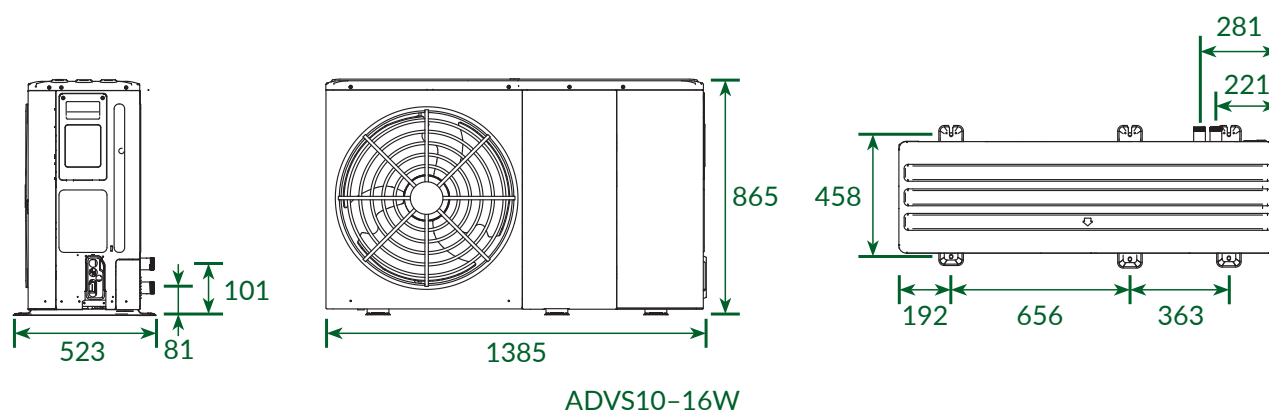

Technical Specifications		ADVS10W	ADVS12W	ADVS16W
Heating Performance Water outlet temperature: 35°C Ambient temperature: 7°C	Maximum heating capacity (kW)	10.00	12.10	15.90
	Rated input (kW)	2.02	2.44	3.53
	COP	4.95	4.95	4.50
Heating Performance Water outlet temperature: 55°C Ambient temperature: 7°C	Maximum heating capacity (kW)	9.50	13.8	16.00
	Rated input (kW)	3.06	4.68	5.61
	COP	3.10	2.95	2.85
Heating Performance Water outlet temperature: 55°C Ambient temperature: -7°C	Maximum heating capacity (kW)	6.95	10.59	12.48
	Rated input (kW)	3.53	5.25	6.15
	COP	1.97	2.02	2.03
SCOP Average climate conditions	Water outlet temperature: 35°C	5.20	4.81	4.62
	Water outlet temperature: 55°C	3.47	3.45	3.41
Seasonal Space Heating Energy Efficiency Class	Water outlet temperature: 35°C	A+++	A+++	A+++
	Water outlet temperature: 55°C	A++	A++	A++
Power Supply	V/Ph/Hz	220-240/1/50		
	Full Load Amps (A)	19	30	30
	Amps Protection (A)	25	35	35
Dimensions	Appliance (mm)	1385 x 865 x 523		
	Packaging (mm)	1465 x 1120 x 560		
Refrigerant	Type	R32	R32	R32
	Charged Volume (kg)	1.40	1.75	1.75
	Throttle Type	Electronic Expansion Valve		
Water Temperature Output Range	DHW (°C)	12 to 60		
	Heating (°C)	12 to 60		
	Cooling (°C)	5 to 25		
Ambient Air Temperature Range	DHW (°C)	-25 to 43		
	Heating (°C)	-25 to 35		
	Cooling (°C)	-5 to 43		
Noise Data	Sound Power Level (dB)	60	65	69
	Sound Pressure @1m (dB(A))	51	53	58
Compressor	Type	Twin Rotary DC Inverter		
	Rated Load Amps (A)	15.50	23.50	25.50
Fan	Type	Brushless DC Motor		
	Rated Motor Output (W)	170	170	170
	Full Load Amps (A)	1.5	1.5	1.5
Internal Water Pump	Max. head (m)	8.7	8.7	8.7
Rated Water Flow	m ³ /h	0.40-2.10	0.70-2.50	0.70-3.00
Water Connections	Inch	1¼" BSP	1¼" BSP	1¼" BSP
Water Circuit Pressure Range		1 to 3 bar	1 to 3 bar	1 to 3 bar
Appliance Mass	Empty/Filled (kg)	105/132	129/155	129/155

ADV16-30W: 16-30kW Three Phase ASHP

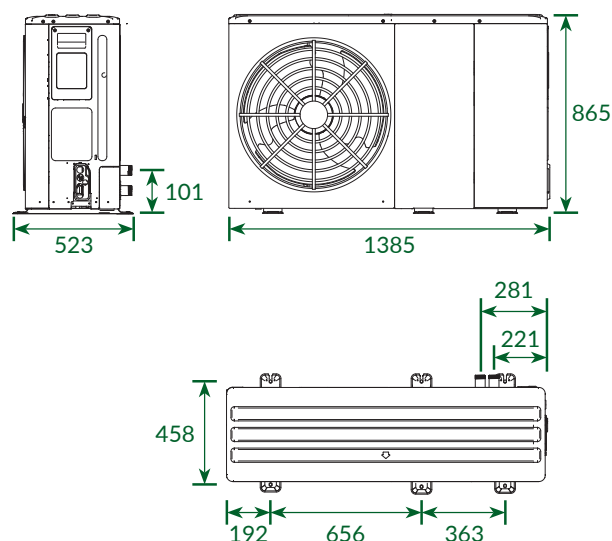

ADV16W

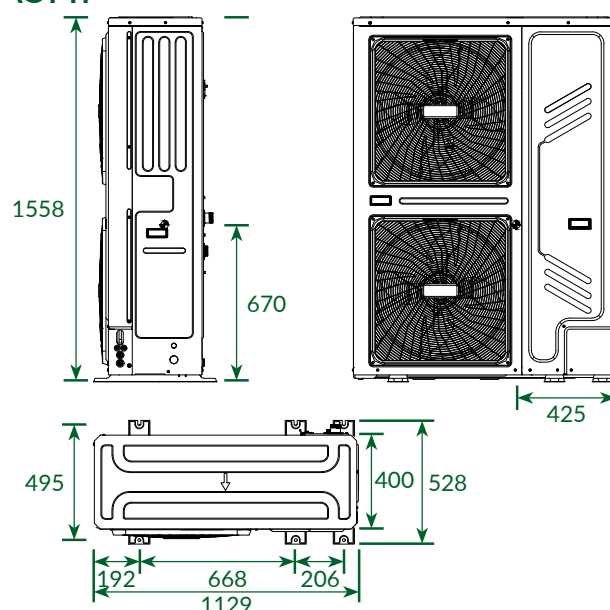

ADV22W - ADV30W

Technical Specifications		ADV16W	ADV22W	ADV30W
Heating Performance Water outlet temperature: 35°C Ambient temperature: 7°C	Maximum heating capacity (kW)	15.90	22.00	30.10
	Rated input (kW)	3.53	5.00	7.69
	COP	4.50	4.40	3.91
Heating Performance Water outlet temperature: 55°C Ambient temperature: 7°C	Maximum heating capacity (kW)	16.00	22.00	30.00
	Rated input (kW)	5.61	8.30	13.04
	COP	2.85	2.65	2.30
Heating Performance Water outlet temperature: 55°C Ambient temperature: -7°C	Maximum heating capacity (kW)	12.48	18.00	21.00
	Rated input (kW)	6.15	11.61	14.00
	COP	2.03	1.55	1.50
SCOP Average climate conditions	Water outlet temperature: 35°C	4.62	4.53	4.19
	Water outlet temperature: 55°C	3.41	3.22	3.14
Seasonal Space Heating Energy Efficiency Class	Water outlet temperature: 35°C	A+++	A+++	A++
	Water outlet temperature: 55°C	A++	A++	A+
Power Supply	V/Ph/Hz	380-415/3/50		
	Full Load Amps (A)	14	28	28
	Amps Protection (A)	16	32	32
Dimensions	Appliance (mm)	1385 x 865 x 523	1129 x 1558 x 528	
	Packaging (mm)	1465 x 1035 x 560	1220 x 1735 x 565	
Refrigerant	Type	R32	R32	R32
	Charged Volume (kg)	1.75	5.00	5.00
	Throttle Type	Electronic Expansion Valve		
Water Temperature Output Range	DHW (°C)	12 to 60	30 to 60	
	Heating (°C)	12 to 60	25 to 60	
	Cooling (°C)	5 to 25	0 to 25	
Ambient Air Temperature Range	DHW (°C)	-25 to 43	-25 to 43	
	Heating (°C)	-25 to 35	-25 to 35	
	Cooling (°C)	-5 to 43	-10 to 46	
Noise Data	Sound Power Level (dB)	69	73	77
	Sound Pressure @1m (dB(A))	58	59	63
Compressor	Type	Twin Rotary DC Inverter		
	Rated Load Amps (A)	11.15	14.00	21.00
Fan	Type	Brushless DC Motor		
	Rated Motor Output (W)	170	340	340
	Full Load Amps (A)	1.5	3	3
Internal Water Pump	Max. head (m)	9.0	12.0	12.0
Rated Water Flow	m ³ /h	4.00	3.78	5.18
Water Connections	Inch	1¼" BSP	1¼" BSP	1¼" BSP
Water Circuit Pressure Range		1 to 3 bar	1 to 3 bar	1 to 3 bar
Appliance Mass	Empty/Filled (kg)	144/172	177/206	177/206

Advenco Ardent 9–36 kW

Indirect Electric Wall-Hung Boilers



The Advenco Ardent range of wall-hung electric boilers are designed to provide a high capacity, reliable, and compact solution to a building's hot water and central heating demands.

The Advenco Ardent electric boiler range features multiple electric heating elements immersed into an integrated water storage tank to provide a rapid and reliable source of thermal energy to serve a heating system or indirect water heater.

Available as a compact wall-hung appliance with outputs from 9 to 36 kW, the Ardent electric boiler range includes stepped power control to provide optimum heating output and economically adjust the heating load when approaching the set point temperature, and range rating to tailor the boiler power to suit the application. The Ardent range is available in two model ranges:

S Range: The Ardent Standard range features three heating elements with thermostat input and output control to an external pump.

P Range: The Ardent Premium range features six to nine heating elements and an integrated expansion vessel, relief valve, and circulation pump. The Premium range features all controls of the Standard range in addition to controls for a 3-port valve and fault output.

All boilers feature a front mounted LCD display and protective IP20 or IP40-rated outer shell as well as integrated overheat safety protection. The Ardent range is ideal for integration with heat pump systems to provide a high temperature energy source in the coldest period of the year.

FEATURES

- Indirect hot water system design eliminates scale build-up common on direct electrical immersion heaters.
- Multiple heating elements per unit provide inbuilt redundancy.
- Stepped element control to reduce start-up current and excessive or uneven wear on heating elements.
- Compact wall-hung arrangement.
- Simple integration into existing systems.
- Modern electric-only operation avoids reliance on gas energy supplies.

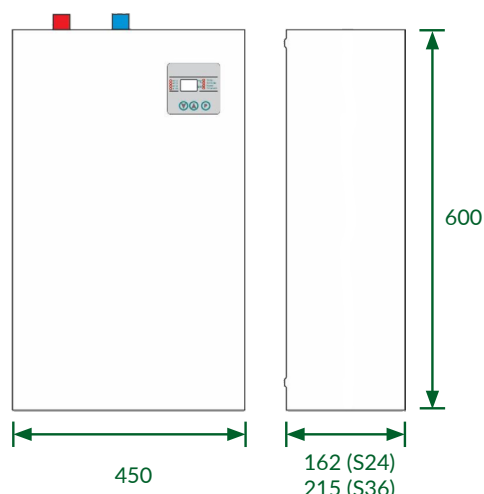

Ardent Standard: S24–S36

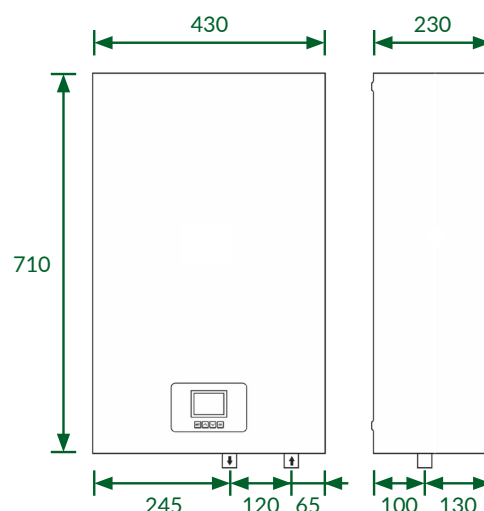

Ardent Premium: P9–P24

Ardent Standard: Technical Specifications

	S24	S36
Heat output range (kW)	24.0	36.0
Element configuration	3 × 8.0	3 × 12.0
Power supply (V _{AC} / Phases / Hz)	400 / 3 phase / 50	
Full load current per phase (A)	34.8	52.2
Inlet and outlet connections	1" (DN25)	
Boiler water content (l)	14.2	21.0
Maximum operating temperature (°C)	80	
Operating pressure range (bar)	0.5 – 3.0	
Energy efficiency class	D	
Sound power level (dB)	46	
Housing protection	IP20	
Dimensions H × W × D (mm)	600 × 450 × 162	600 × 450 × 215
Dry mass (kg)	13.5	17.2

Ardent Premium: Technical Specifications

	P9	P12	P24
Heat output range (kW)	9.0	12.0	24.3
Element configuration	6 × 1.5	6 × 2.0	9 × 2.7
Power supply (V _{AC} / Phases / Hz)	240 / 1 phase / 50 or 400 / 3 phase / 50	400 / 3 phase / 50	
Full load current per phase (A)	38 (1 phase) 13 (3 phase)	17.4	35.2
Inlet and outlet connections (inch)	G 3/4"	G 3/4"	G 3/4"
Boiler water content (l)	12.5	12.5	12.5
Expansion vessel water content (l)	7.0	7.0	7.0
Maximum operating temperature	80	80	80
Operating pressure range (bar)	0.8 – 2.2	0.8 – 2.2	0.8 – 2.2
Energy efficiency class	D	D	D
Sound power level (dB)	32	32	32
Housing protection	IP40	IP40	IP40
Dimensions H × W × D (mm)	700 × 430 × 230	700 × 430 × 230	700 × 430 × 230
Dry mass (kg)	25	25	25

ATST 300-1000

Stainless Steel Twin-Coil Cylinders for DHW Applications

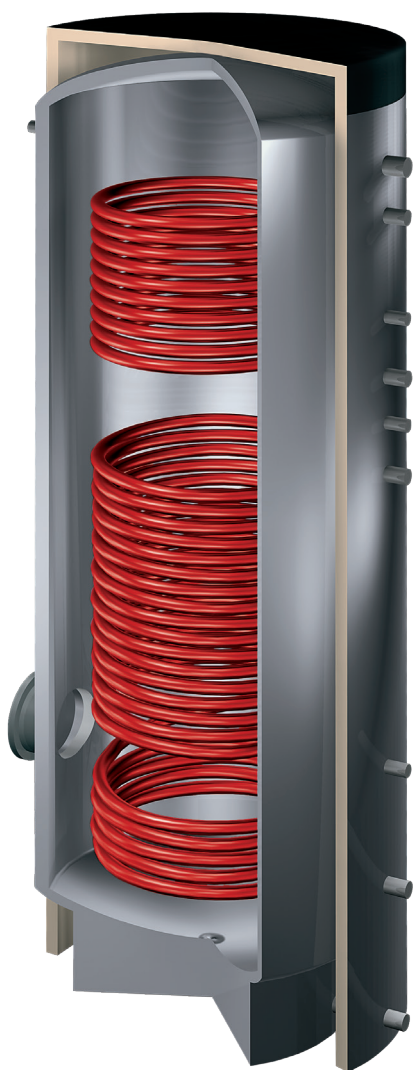

The Adveco ATSt range of stainless steel hot water tanks serve as buffer vessels and indirect hot water calorifiers suitable for use with high pressure applications.

The ATST is a high quality indirect water heater constructed from corrosion resistant AISI 316Ti and 316L stainless steel. Each vessel features two primary fixed heating coils, at low and high level, for use with multiple heat sources, as well as several connection points and a clean-out access flange.

All tanks are designed, manufactured, and tested to the requirements of the Pressure Equipment Directive (97/23/EC) and EN 12897.

FEATURES

- Available with 300 - 1000 litre capacities
- Produced from high quality 316Ti and 316L stainless steel
- 100 mm removable insulation for improved energy efficiency
- Suitable for vented or unvented installation
- 10 bar / 95°C max. working pressure/temp (tank)
- 25 bar / 200°C max. working pressure/temp (coil)

OPTIONS & ANCILLARIES

- E0008/0-95C: Control Thermostat with 0-95°C range
- E0011: Overheat thermostat
- E0009.2: Chrome thermostat pocket
- Immersion heater options from 3-12 kW
- MB0001: Destratification pump kit
- Unvented Kits: Contact Adveco for options and details

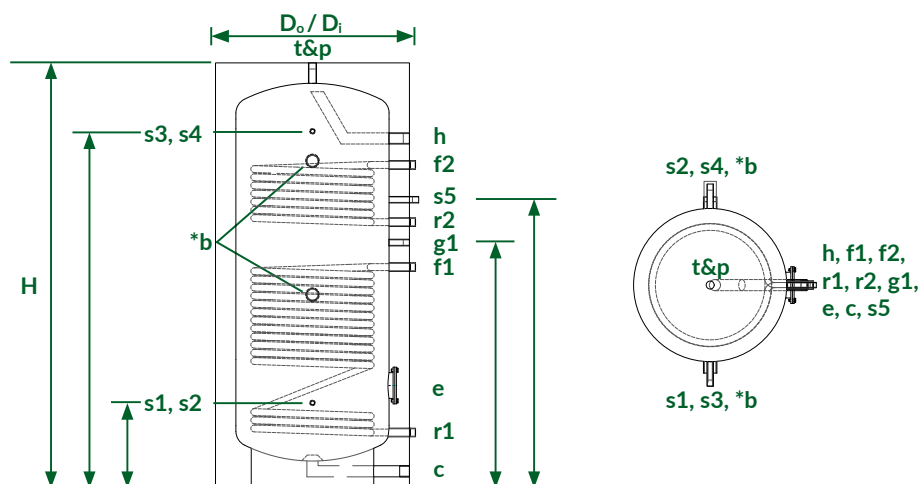

Specifications

Description		300	400	500	580	750	1000
Storage volume (l)		289	411	490	575	756	990
Standing losses (W) / Energy efficiency class		66 / B	76 / B	83 / B	105 / C	120 / C	140 / C
Coil surface area (m ²)	Lower coil	1.4	1.7	1.7	1.8	2.4	2.4
	Upper coil	0.8	0.9	0.9	0.9	1.4	1.8
Output capacity (kW) (80/60:10/60)	Lower coil	29.7	36.1	36.1	38.3	51.0	59.0
	Upper coil	17.0	19.1	19.1	19.1	29.7	38.3
Nominal primary flow rate (m ³ /h)	Lower coil	1.27	1.55	1.55	1.64	2.19	2.53
	Upper coil	0.73	0.82	0.82	0.82	1.27	1.64
Nominal coil pressure drop (mbar)	Lower coil	124.7	209.3	215.2	247.2	83.7	106.6
	Upper coil	26.1	35.3	36.2	35.3	18.5	36.7
	Lower coil	509.7	619.5	619.5	657.2	875.2	1012.4
Continuous DHW flow rate (l/h) (80/60:10/60)	Upper coil	291.7	327.8	327.8	327.8	509.7	657.2
	Combined coils	801.4	947.2	947.2	985.0	1384.8	1669.7
Peak draw off capacity (l) Combined coils (80/60:10/60)	30 min.	565	723	787	870	1182	1488
	60 min.	971	1203	1266	1369	1883	2333
	120 min.	1767	2144	2208	2348	3259	3992
Dry mass (kg)		72	90	110	105	160	200

Connections

Label	Description	300	400	500	580	750	1000
c, h	Water inlet and outlet	1"	1"	1"	1½"	1½"	2"
f1, r1, f2, r2	Heat exchangers flow and return	1"	1"	1"	1"	1¼"	1¼"
t&p	T&P relief valve connection	1"	1"	1"	1"	1"	1"
g1	Additional connection	¾"	¾"	¾"	¾"	¾"	1"
s1, s2, s3, s4, s5	Sensor pockets	¾"	¾"	¾"	¾"	¾"	¾"
e	Clean-out flange (mm)	Ø180/120	Ø180/120	Ø180/120	Ø180/120	Ø180/120	Ø180/120

Dimensions

Label	Description	300	400	500	580	750	1000
H	Height including insulation	1740	1735	1990	1990	2080	2080
D_o	Outer diameter with insulation	Ø700	Ø800	Ø800	Ø850	Ø950	Ø1050
D_i	Inner diameter without insulation	Ø500	Ø600	Ø600	Ø650	Ø750	Ø850
g1	Additional connection	925	960	1100	1190	1200	975
s1, s2	Sensor pockets	380	405	545	405	405	505
s3, s4	Sensor pockets	1415	1440	1695	1690	1745	1745
s5	Sensor pocket	1130	1150	1320	1390	1410	1200

All threaded connections are BSPT female unless otherwise stated. Coil connections BSPT male. All dimensions in mm.

810366(K) Control Panel

ASHP and Electric Auto-Changeover Wiring Station



Advenco provide a range of tailored prewired hot water control solutions. The 810366 is a complete wiring station for use with packaged electric hot water systems such as the Advenco FUSION.

The 810366 is designed to provide power and controls to all elements of a packaged electric hot water system, including options for air source heat pumps, electric boilers, pumps, and automatic activation of backup immersion heaters in the event of a primary appliance fault. The panel additionally includes overload protection and volt free contacts for complete BMS integration and monitoring via fault output. The 810336K kit adds an integrated mobile GSM module to provide email or SMS fault alert notifications.

The panel features an accessible front-mounted rotary system isolation point and two status lamps to clearly display the operational condition of the system at a glance. All components are protected within an IP65-rated wall mountable enclosure.

Specifications

Order code	Control panel only: 810366 Control panel kit with GSM: 810366K
Incoming supply voltage(s)	415 V / 3 phase / 50 Hz
Output supply voltage(s)	415 V / 3 phase / 50 Hz 230 V and 110 V / 1 phase / 50 Hz 12 V and 24 V DC
Max. incoming supply breaker size	63 A
Max. supported electric boiler power	24 kW
Max. supported ASHP current	20 A / 1phase when powered from 810366 panel Higher output ASHP supported when using independent ASHP power supply
Max. supported immersion power	12 kW / 3 phase. Automatically activated upon fault from boiler or ASHP as standard.
Included time controls	1× Hot water system control 1× Thermal disinfection cycle control
Included pump support (Power and controls)	1× Secondary return pump 1× Thermal disinfection/destratification pump 1× Low loss header pump
Communication	Volt-free contacts for BMS integration for remote control of: <ul style="list-style-type: none"> • Hot water system enable and disable • Thermal disinfection and high-temperature pasteurisation • Fault signal outputs
Additional outputs for packaged plant rooms	Kiosk lighting and 120W electric space heater 1× 240 V power socket
Panel dimensions H × W × D	600 mm × 400 mm × 200 mm (600 mm door open)
Mounting configuration	Wall mounted (brackets included)
Mass	5 kg

In the event of a fault status on the electric boiler or air source heat pump, the control panel will automatically activate the backup immersion heater to cover part of the system demand. By removing a link wire in the panel, the immersion heater can be prevented from activating on ASHP fault in order to restrict the maximum control panel power draw for sites with limited supplies. The connected air source heat pump must be configured locally to deliver a fault output to the panel.

For further details about connected appliances, refer to the respective product technical data sheets and the control panel wiring diagram available from Advenco.

Final connections within the panel should be completed by a fully qualified engineer during the installation and commissioning of the system. All control relays, incoming, and outgoing supply cables must be appropriately sized. All communication and digital controller connections must use screened and earthed cabling.

Only one supply is required for the air source heat pump. Heat pumps not listed below require an independent power supply from a local distribution board. Individual appliance loads for typical Advenco packaged electric hot water systems can be seen below.

Full Load Amps for Advenco Packaged Electric Hot Water Systems

ASHP Model	Backup Immersion Model	Electric Boiler Models	
		P12	P24
FPI32-6	No Immersion	28.4 A	46.2 A
	6 kW Immersion	28.4 A	46.2 A
	9 kW Immersion	30.5 A	48.3 A
	12 kW Immersion	34.8 A	52.6 A
FPI32-9	No Immersion	32.4 A	50.2 A
	6 kW Immersion	32.4 A	50.2 A
	9 kW Immersion	32.4 A	50.2 A
	12 kW Immersion	34.8 A	52.6 A
FPI32-12	No Immersion	35.4 A	53.2 A
	6 kW Immersion	35.4 A	53.2 A
	9 kW Immersion	35.4 A	53.2 A
	12 kW Immersion	35.4 A	53.2 A
ADVS10W	No Immersion	36.4 A	54.2 A
	6 kW Immersion	36.4 A	54.2 A
	9 kW Immersion	36.4 A	54.2 A
	12 kW Immersion	36.4 A	54.2 A
Independent supply to other ASHP	No Immersion	17.4 A	35.2 A
	6 kW Immersion	26.1 A	43.9 A
	9 kW Immersion	30.5 A	48.3 A
	12 kW Immersion	34.8 A	52.6 A

810118K–810124K

3/6/9/12/15/18 kW Electric Immersion Heaters



Adveco offer a wide range of electric immersion heater elements and kits designed for use with domestic hot water systems as primary or backup heat sources.

Direct electric immersion heaters provide a reliable source of hot water and are ideal for use with electric-only or renewable hot water systems. When used as a backup, an electric immersion heater is a practical alternative to installation of an entire secondary heating appliance, and is both unobtrusive to existing systems and easily maintained.

Each immersion heater features a 2.25" brass boss which connects using a supplied stainless steel adapter flange to fit clean-out access points of a hot water tank, and is supplied complete with control and overheat cut-out thermostats contained within the IP55-rated terminal. All elements are sheathed with Nicalloy 825 and are operable up to temperatures of 90°C and pressures of up to 6 Bar.

Specifications		810118K	810119K	810120K	810121K	810122K	810123K	810124K
Capacity		3 kW	6 kW	9 kW		12 kW	15 kW	18 kW
Supply	Single Phase	230 V / 1 phase / 50 Hz		n/a	230 V / 1 phase / 50 Hz	n/a	n/a	n/a
	Three Phase	415 V / 3 phase / 50 Hz			n/a	415 V / 3 phase / 50 Hz		
Wiring	Single Phase	L, N, E		n/a	L, N, E	n/a	n/a	n/a
	Three Phase	L1, L2, L3, N, E			n/a	L1, L2, L3, N, E		
Power	Single Phase	13 A	26 A	n/a	39 A	n/a	n/a	n/a
	Three Phase	5 A / phase	9 A / phase	13 A / phase	n/a	18 A / phase	22 A / phase	26 A / phase
Heat intensity		8.7 W/cm ²	9.2 W/cm ²	9.2 W/cm ²	9.3 W/cm ²	10.4 W/cm ²	9.3 W/cm ²	7.8 W/cm ²
Max. Working Temperature		90°C						
Max. Working Pressure		6 bar						
Immersed length		375 mm (14.75")	460 mm (18.1")	460 mm (18.1")	460 mm (18.1")	510 mm (20.0")	685 mm (27")	915 mm (36")
Cold foot length		100 mm (3.9")	100 mm (3.9")	100 mm (3.9")	100 mm (3.9")	100 mm (3.9")	100 mm (3.9")	100 mm (3.9")



Ancillaries	810118K	810119K	810120K	810121K	810122K	810123K	810124K
Thermostats supplied *	E0043.1 Integrated (T1) control thermostat: Control range: 30-70°C E0044 Integrated (T2) overheat setpoint: 95°C				E0010 Dual stat: Control range: 25-65°C Overheat set: 80°C		E0008/0-95C Control range: 0-95°C E0009 Over- heat set: 95°C
2.25" gasket	E0042.3						
2.25" to 180mm adaptor flange plate	810076						
180mm EPDM gasket	E0042.1						

*: Consideration should be given to the use of non-integrated thermostats for immersion heaters over 9 kW or those used as primary heat sources. For further information please contact Advenco.

810118K, 810119K
Single Phase
Terminal Layout

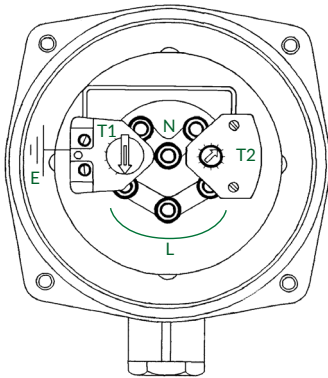

810118K, 810119K
Three Phase
Terminal Layout

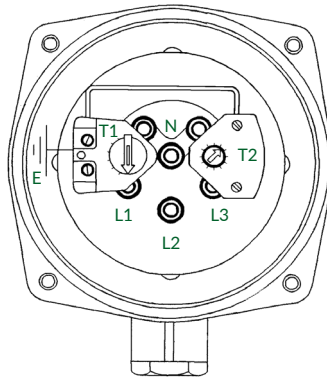

810120K, 810121K, 810122K
Three Phase
Terminal Layout

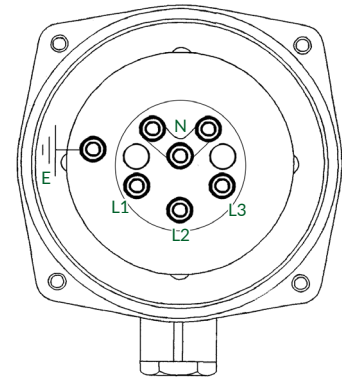

Suggested Wiring Layout:

Suitable contactor switches are required for all installations. For three phase supplies, the copper busbar connecting the live terminals should be removed. Note that fuses, contactors, isolators and on/off switches must be supplied separately.

This appliance must be earthed.

Single Phase

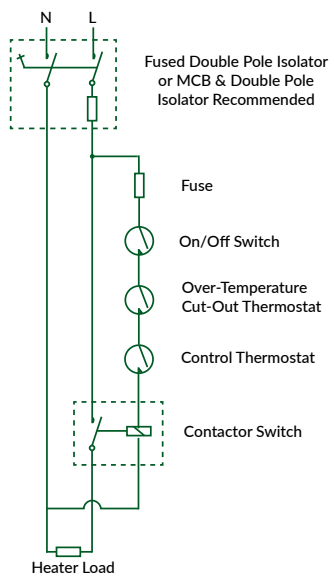

Three Phase

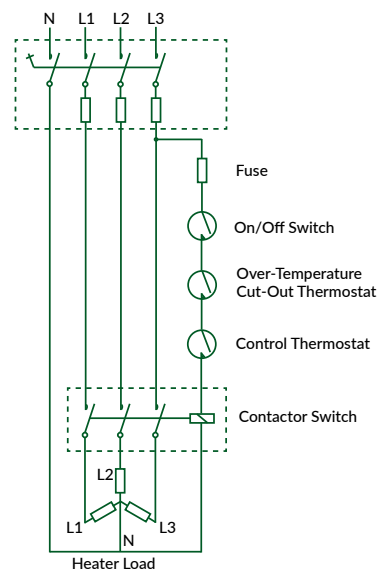

M0007 / MB0001 Single Head Pump

DHW Circulation Pump for Destratification and Return



Pump Specifications

Medium	Water
Nominal pressure	10 bar (PN 10)
Specific EEI	≤ 0.15
Rated voltage / frequency	230 V / 50 Hz
Rated current	0.5 A
Degree of protection	IP44
Insulation class	F
Sound pressure level	≤ 43 db(A)

Materials

Pump body	Stainless steel AISI 304
Motor housing	Aluminium
Impeller	PPE/PS-I Composite
Shaft	Alumina ceramic
Thrust bearing housing	EPDM
Thrust bearing	Graphite
O-ring	EPDM
Wear ring	Stainless steel AISI 304
Rotor can	Stainless steel AISI 316L
Rotor plastic	PPS composite
Rotor sleeve	Stainless steel AISI 304
Control box	PC composite
Front bearing housing	Stainless steel AISI 304

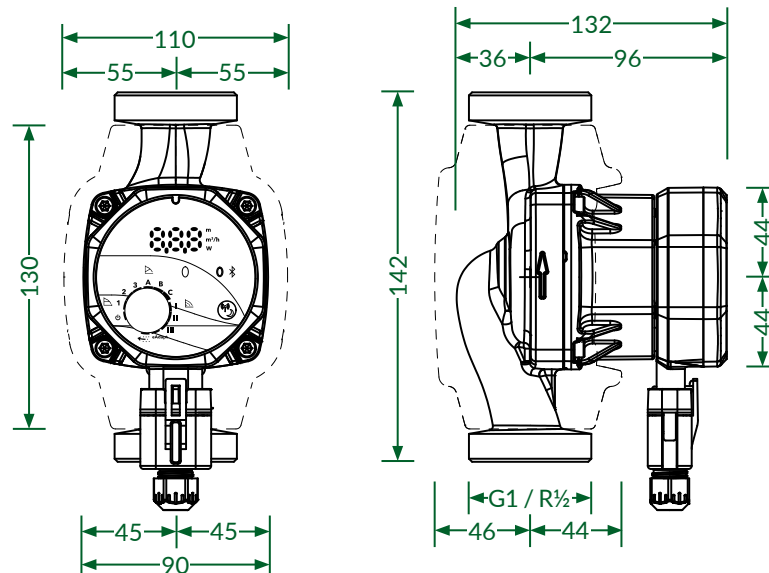

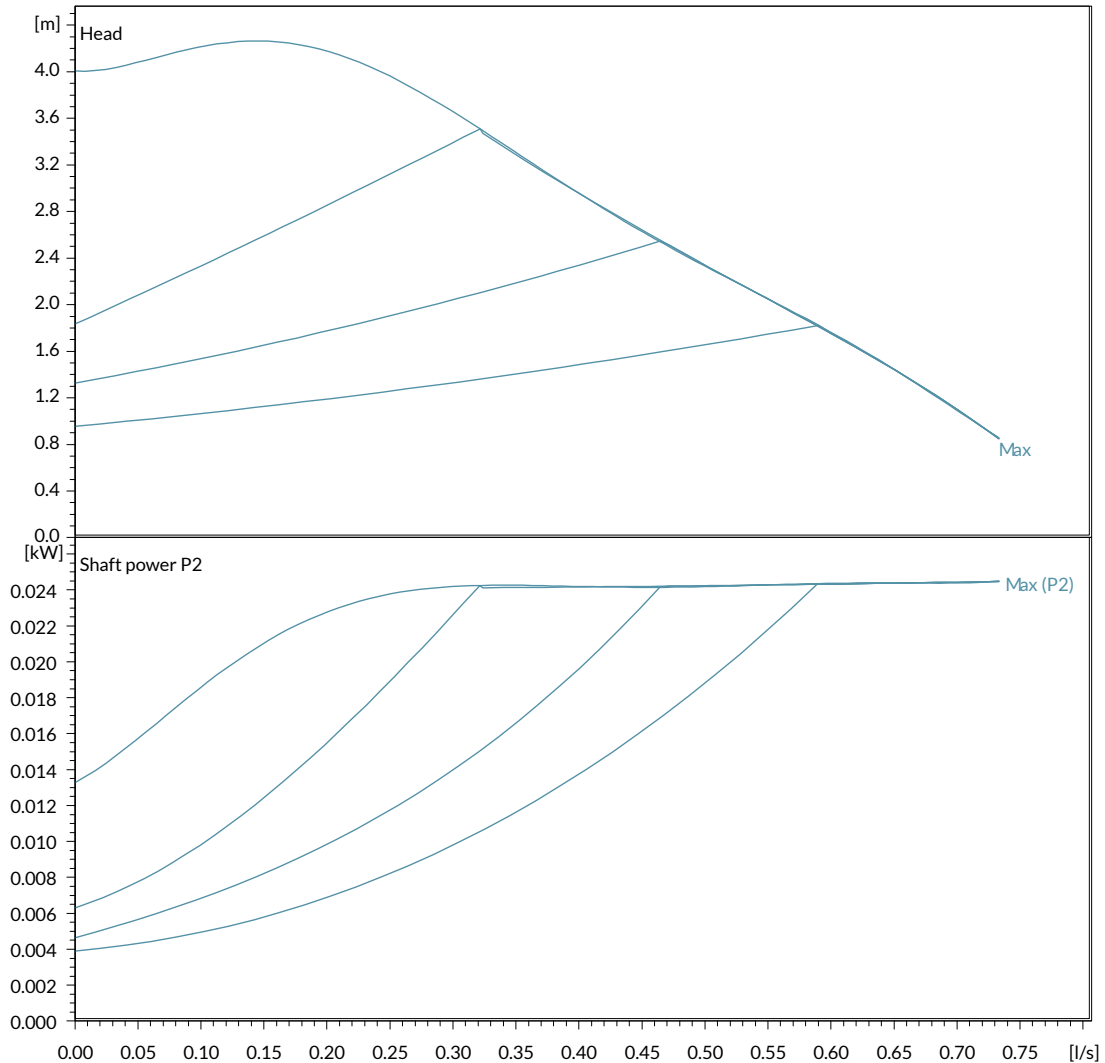

Performance according to ISO 9906:2012 - Grade 3B

Power datas referred to:

Water, pure [100%]; 4°C; 1000kg/m³; 1.57mm²/s